



UNIVERSITY OF CAMBRIDGE INTERNATIONAL EXAMINATIONS
General Certificate of Education
Advanced Subsidiary Level and Advanced Level

PHYSICS

9702/35

Paper 31 Advanced Practical Skills 1

May/June 2010

CONFIDENTIAL INSTRUCTIONS



Great care should be taken to ensure that any confidential information given does not reach the candidates either directly or indirectly.

No access to the Question Paper is permitted in advance of the examination.

bestexamhelp.com

If you have any problems or queries regarding these Instructions, please contact CIE
by e-mail: international@cie.org.uk,
by phone: +44 1223 553554,
by fax: +44 1223 553558,
stating the Centre number, the nature of the query and the syllabus number quoted above.

This document consists of **7** printed pages and **1** blank page.



Preparing apparatus

These instructions detail the apparatus required for the experiments in the Question Paper. It is essential that absolute confidentiality is maintained in advance of the examination: the contents of these instructions must not be revealed either directly or indirectly to candidates.

No access is permitted to the Question Paper in advance of the examination.

If you have problems or queries regarding these instructions, please contact CIE:

by e-mail: international@cie.org.uk,
or by telephone: +44 1223 553554,
or by fax: +44 1223 553558,

stating the nature of the query and quoting the syllabus and paper numbers (9702/35).

It is assumed that the ordinary apparatus of a Physics laboratory will be available.

Number of sets of apparatus

The number of sets of apparatus provided for each experiment should be $\frac{1}{2}N$, where N is the number of candidates taking the examination. There should, in addition, be a few spare sets of apparatus available in case problems arise during the examination.

Organisation of the examination

Candidates should be allowed access to the apparatus for each experiment for one hour only. After spending one hour on one experiment, candidates should change over to the other experiment. The order in which a candidate attempts the two experiments is immaterial.

Assistance to Candidates

Candidates should be informed that, if they find themselves in real difficulty, they may ask the Supervisor for practical assistance, but that the extent of this assistance will be reported to the Examiner, who may make a deduction of marks.

Assistance should only be given:

when it is asked for by a candidate,
or as directed in the Notes sections of these instructions,
or where apparatus is seen to have developed a fault.

Assistance should be restricted to enabling candidates to make observations and measurements. Observations and measurements must not be made for candidates, and no help should be given with data analysis or evaluation.

All assistance given to candidates must be reported on the Supervisor's Report Form.

Faulty apparatus

In cases of faulty apparatus (not arising from a candidate's mishandling) that prevent the required measurements being taken, the Supervisor may allow extra time to give the candidate a fair opportunity to perform the experiment as if the fault had not been present. The candidate should use a spare copy of the Question Paper when the fault has been rectified or when working with a second set of apparatus.

Supervisor's Report

The Supervisor should complete the Supervisor's Report Form on pages 7 and 8 and enclose it in the envelope containing the answers of the candidates. If more than one envelope is used, a copy of the report must be enclosed in each envelope.

Question 1**Apparatus requirements (per set of apparatus unless otherwise specified)**

0–12V D.C. variable power supply (continuous or stepped with 1 V steps or smaller).

Switch.

47 Ω resistor with power rating of at least 0.25W. See Note 1.

12V, 0.1 A filament lamp in holder (e.g. lamp 41-0142 from Rapid Electronics, www.rapidonline.com).

D.C. voltmeter (analogue or digital) with at least 0–12V range reading to 0.1 V or better. See Note 2.

D.C. ammeter (analogue or digital) with at least 0–100 mA range reading to 1 mA or better. See Note 2.

Eight connecting leads, suitable for the candidate to make connections between the components.

Notes

- 1 The resistor should have suitable terminals for connection to the other components (e.g. by use of a component holder or crocodile clips). It should be clearly labelled '47 Ω '.
- 2 If a multimeter is used, it should be preset to the appropriate mode and range.
- 3 If the apparatus is to be used by a second candidate, then it should be dismantled and laid out on the bench. Check the lamp and replace it if necessary.

Information required by Examiners

Sample set of numerical results, clearly labelled "Supervisor's Results" and obtained out of sight of the candidates.

Question 2

Apparatus requirements (per set of apparatus unless otherwise specified)

Expendable spring with outside diameter about 15 mm, coiled length about 20 mm, spring constant about 25 N m^{-1} (e.g. Philip Harris product code 1397 or Timstar SP13863).

Mass hanger with masses to a total of 300 g. See Note 1.

Sheet of stiff card approximately A4 size (colour not important).

Thin plastic or paper tube about 20 cm in length (a drinking straw would be suitable). See Note 1.

Adhesive tape (e.g. Sellotape). See Note 1.

Clear measuring cylinder or beaker of minimum height 20 cm and minimum diameter 5 cm.

Enough vegetable oil (cooking oil) to fill the measuring cylinder to 1 cm from the top. See Note 2.

Tray to contain any spillage.

Paper towels.

Stopwatch reading to 0.1 s or better.

Two retort stands, each with a boss and clamp.

30 cm ruler with a millimetre scale.

Strip of stiff card about $2 \text{ cm} \times 10 \text{ cm}$, marked as shown in Fig. 2.1.

Notes

- The tube should be rigidly fixed to the masses and hanger with adhesive tape and the apparatus assembled as shown in Fig. 2.1.

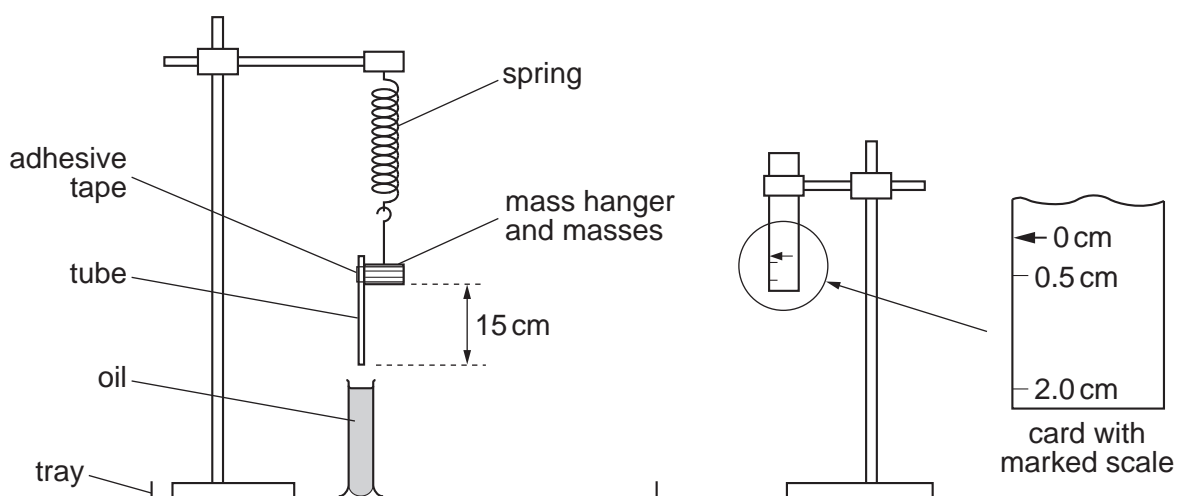

Fig. 2.1

- 2 The oil should be transparent enough for the text of these Instructions to be seen through the filled measuring cylinder or beaker.
- 3 If the apparatus is to be used by a second candidate, then it should be restored to its original state.

Information required by Examiners

Sample set of numerical results, clearly labelled "Supervisor's Results" and obtained out of sight of the candidates.

BLANK PAGE

Permission to reproduce items where third-party owned material protected by copyright is included has been sought and cleared where possible. Every reasonable effort has been made by the publisher (UCLES) to trace copyright holders, but if any items requiring clearance have unwittingly been included, the publisher will be pleased to make amends at the earliest possible opportunity.

University of Cambridge International Examinations is part of the Cambridge Assessment Group. Cambridge Assessment is the brand name of University of Cambridge Local Examinations Syndicate (UCLES), which is itself a department of the University of Cambridge.

This form should be completed and sent to the Examiner with the scripts.

SUPERVISOR'S REPORT FORM

General Certificate of Education Advanced Subsidiary Level and Advanced Level

May/June Session 2010

The Supervisor's Report should give full details of:

- (a) any help given to a candidate (including the nature of the help given and the name and candidate number of the candidate);
- (b) any cases of faulty apparatus (including the nature of the problem, the action taken to rectify it, any additional time allowed, and the name and candidate number of the candidate);
- (c) any accidents that occurred during the examination;
- (d) any other difficulties experienced by candidates, or any other information that is likely to assist the Examiner, especially if this information cannot be discovered in the scripts.

Cases of individual hardship, such as illness, bereavement or disability, should be reported direct to CIE on the normal Special Consideration form.

Information required by Examiners

For each question, please enclose a sample set of numerical results, obtained out of sight of the candidates and clearly labelled "Supervisor's Results".

Supervisor's Report



Supervisor's Report (continued)

Declaration

(to be signed by the Supervisor)

The preparation of this practical examination has been carried out so as to maintain fully the security of the examination.

Signed

Name

Centre Number

Name of Centre

