

# CHEMISTRY

**Paper 9701/11**  
**Multiple Choice**

<i>Question Number</i>	<i>Key</i>	<i>Question Number</i>	<i>Key</i>
1	A	21	A
2	A	22	A
3	D	23	B
4	C	24	B
5	B	25	A
6	A	26	B
7	D	27	C
8	D	28	B
9	D	29	D
10	C	30	C
11	C	31	B
12	A	32	B
13	A	33	A
14	B	34	D
15	C	35	B
16	D	36	C
17	D	37	B
18	C	38	D
19	B	39	C
20	C	40	A

## General comments

Candidates found **Questions 1, 5, 7, 10, 11, 12, 14, 16, 18, 19, 21, 24, 28, 33** and **36** to be more accessible than other questions. Candidates found **Questions 3, 9, 13, 20, 37** and **39** to be more challenging. The questions that were found to be particularly difficult will now be looked at in greater detail.

### Comments on specific questions

#### Question 3

The most commonly chosen incorrect answer was **B**. Answer **B**, propane, is incorrect because the bond angle at each carbon atom is close to  $109^\circ$ . Answer **D**, sulfur hexafluoride, is correct as the bond angles are all  $90^\circ$ , thus there are three sets of F-S-F atoms that form a straight line.

#### Question 9

The most commonly chosen incorrect answer was **A**. If  $b$  moles of HI are there at the start, the total number of moles present will always be  $b$ . At equilibrium the partial pressure of HI is  $p(b-x)/b$ . The partial pressures of  $H_2$  and  $I_2$  are both  $px/2b$ . If these values are put into the equilibrium expression we get  $x^2/4(b-x)$ . The choice of **A** suggests many candidates did not appreciate that each mole of HI gives half a mole of  $H_2$  and half a mole of  $I_2$ .

#### Question 13

The most commonly chosen incorrect answer was **C**. Element Y cannot be Ca or Mg because  $Ca(OH)_2$  and  $Mg(OH)_2$  do not dissolve in excess NaOH. However,  $Al(OH)_3$  does dissolve in excess NaOH, so the answer is **A**.

#### Question 20

The most commonly chosen incorrect answer was **B**. Compound Q has one C=C bond that is bonded to four different groups, giving a pair of cis-trans isomers. There is one chiral carbon atom so each of the cis-trans isomers exists as a pair of optical isomers. Therefore, there are four stereoisomers.

#### Question 37

The most commonly chosen incorrect answer was **C**. This suggests that most candidates knew that the three carbon atoms in propane all lie in the same plane. The six carbon atoms in 2,3-dimethylbut-2-ene also all lie in the same plane, since the bond angles at an  $sp^2$  hybridised carbon atom are very close to  $120^\circ$ , and the  $\pi$  bond prevents rotation. However, the six carbon atoms in cyclohexane do not lie in the same plane, they are all  $sp^3$  hybridised with bond angles close to  $109^\circ$ .

#### Question 39

The most commonly chosen incorrect answer was **A**. The choice of **A** suggests that for a significant number of candidates the key point of this question was whether or not compound 1 gives a positive iodoform test. For a positive iodoform test either  $-COCH_3$  or  $-CH(OH)CH_3$  must be present. Compound 1 has a  $-C(OH)(CH_3)_2$  group, an aldehyde group and an alkene group, none of which will give a positive iodoform test.

# CHEMISTRY

**Paper 9701/12**  
**Multiple Choice**

<i>Question Number</i>	<i>Key</i>	<i>Question Number</i>	<i>Key</i>
1	<b>A</b>	21	<b>A</b>
2	<b>C</b>	22	<b>B</b>
3	<b>B</b>	23	<b>A</b>
4	<b>C</b>	24	<b>B</b>
5	<b>C</b>	25	<b>B</b>
6	<b>D</b>	26	<b>A</b>
7	<b>B</b>	27	<b>C</b>
8	<b>D</b>	28	<b>B</b>
9	<b>C</b>	29	<b>D</b>
10	<b>D</b>	30	<b>C</b>
11	<b>A</b>	31	<b>A</b>
12	<b>A</b>	32	<b>B</b>
13	<b>B</b>	33	<b>D</b>
14	<b>C</b>	34	<b>D</b>
15	<b>C</b>	35	<b>A</b>
16	<b>A</b>	36	<b>B</b>
17	<b>A</b>	37	<b>A</b>
18	<b>B</b>	38	<b>B</b>
19	<b>C</b>	39	<b>D</b>
20	<b>C</b>	40	<b>B</b>

## General comments

Candidates found **Questions 1, 2, 4, 7, 9, 11, 14, 17, 18, 21, 23, 29, 31** and **35** to be more accessible questions. Candidates found **Questions 5, 13, 24, 34, 39** and **40** to be more challenging. The questions that were found to be particularly difficult will now be looked at in greater detail.

### Comments on specific questions

#### Question 5

The most commonly chosen incorrect answer was **A**. For an ideal gas  $pV=nRT$  and rearranging this gives  $pV/RT=n$ , which is a constant for any sample of ideal gas. Answer **A** shows  $pV/RT$  increasing, but answer **C** shows it remaining constant, so **C** is the correct answer.

#### Question 13

The most commonly chosen incorrect answer was **D**, but phosphorus does not have a giant structure. Aluminium is giant metallic and aluminium chloride reacts with water to give an acidic solution. Silicon is giant covalent and silicon tetrachloride reacts with water to give an acidic solution. **B** is therefore the correct answer.

#### Question 24

The most commonly chosen incorrect answer was **C**. 2,3-dimethylpenta-1,4-diene (choice **C**) is not possible because the intermediate produced on treatment with cold, dilute  $\text{KMnO}_4$ , 2,3 dimethylpentane-2,3-diol, cannot dehydrate to give double bonds in the 1 and 4 positions. However, it can dehydrate to give double bonds in the 1 and 3 positions. It was expected that candidates would draw the structure of the intermediate on their question paper to help them select the correct option.

#### Question 34

The most commonly chosen incorrect answer was **B**. For most candidates this question rested on the truth, or otherwise, of statement 2. The acidity of  $\text{HCO}_2\text{H}$  is not increased by having two hydrogen atoms per molecule, as the H-C bond is strong and difficult to hydrolyse. Choice 2 was therefore incorrect and the answer was **D**.

#### Question 39

The most commonly chosen incorrect answer was **C**. This question required candidates to know the mechanism of nucleophilic addition. The first step is attack by  $\text{CN}^-$ , so statement 1 is correct and statement 2 is incorrect. Esters do not undergo nucleophilic addition, so statement 3 is incorrect and the answer is **D**.

#### Question 40

The most commonly chosen incorrect answer was **A**. The products of the reactions are:

- statement 1 – sodium butanoate, carbon dioxide and water.
- statement 2 – sodium butanoate and hydrogen
- statement 3 – sodium butanoate and water.

Therefore, only the reactions in statements 1 and 2 produce gases and the answer is **B**.

# CHEMISTRY

**Paper 9701/13**  
**Multiple Choice**

<i>Question Number</i>	<i>Key</i>	<i>Question Number</i>	<i>Key</i>
1	A	21	A
2	A	22	A
3	D	23	B
4	C	24	B
5	B	25	A
6	A	26	B
7	D	27	C
8	D	28	B
9	D	29	D
10	C	30	C
11	C	31	B
12	A	32	B
13	A	33	A
14	B	34	D
15	C	35	B
16	D	36	C
17	D	37	B
18	C	38	D
19	B	39	C
20	C	40	A

## General comments

Candidates found **Questions 1, 5, 7, 10, 11, 12, 14, 16, 18, 19, 21, 24, 28, 33** and **36** to be more accessible than other questions. Candidates found **Questions 3, 9, 13, 20, 37** and **39** to be more challenging. The questions that were found to be particularly difficult will now be looked at in greater detail.

### Comments on specific questions

#### Question 3

The most commonly chosen incorrect answer was **B**. Answer **B**, propane, is incorrect because the bond angle at each carbon atom is close to  $109^\circ$ . Answer **D**, sulfur hexafluoride, is correct as the bond angles are all  $90^\circ$ , thus there are three sets of F-S-F atoms that form a straight line.

#### Question 9

The most commonly chosen incorrect answer was **A**. If  $b$  moles of HI are there at the start, the total number of moles present will always be  $b$ . At equilibrium the partial pressure of HI is  $p(b-x)/b$ . The partial pressures of  $H_2$  and  $I_2$  are both  $px/2b$ . If these values are put into the equilibrium expression we get  $x^2/4(b-x)$ . The choice of **A** suggests many candidates did not appreciate that each mole of HI gives half a mole of  $H_2$  and half a mole of  $I_2$ .

#### Question 13

The most commonly chosen incorrect answer was **C**. Element Y cannot be Ca or Mg because  $Ca(OH)_2$  and  $Mg(OH)_2$  do not dissolve in excess NaOH. However,  $Al(OH)_3$  does dissolve in excess NaOH, so the answer is **A**.

#### Question 20

The most commonly chosen incorrect answer was **B**. Compound Q has one C=C bond that is bonded to four different groups, giving a pair of cis-trans isomers. There is one chiral carbon atom so each of the cis-trans isomers exists as a pair of optical isomers. Therefore, there are four stereoisomers.

#### Question 37

The most commonly chosen incorrect answer was **C**. This suggests that most candidates knew that the three carbon atoms in propane all lie in the same plane. The six carbon atoms in 2,3-dimethylbut-2-ene also all lie in the same plane, since the bond angles at an  $sp^2$  hybridised carbon atom are very close to  $120^\circ$ , and the  $\pi$  bond prevents rotation. However, the six carbon atoms in cyclohexane do not lie in the same plane, they are all  $sp^3$  hybridised with bond angles close to  $109^\circ$ .

#### Question 39

The most commonly chosen incorrect answer was **A**. The choice of **A** suggests that for a significant number of candidates the key point of this question was whether or not compound 1 gives a positive iodoform test. For a positive iodoform test either  $-COCH_3$  or  $-CH(OH)CH_3$  must be present. Compound 1 has a  $-C(OH)(CH_3)_2$  group, an aldehyde group and an alkene group, none of which will give a positive iodoform test.

# CHEMISTRY

---

**Paper 9701/21**  
**AS Structured Questions**

## Key messages

Candidates who performed well on this paper were able to:

- use specific vocabulary appropriately
- give correct formulae when identifying specific compounds and ions
- correctly balance equations.

## General comments

This paper proved to be straightforward for many candidates. Stronger responses demonstrated an excellent knowledge and understanding of the following:

- detailed explanations of the effect of temperature on both reaction rate and yield
- the trend in ionisation energy across a period with appropriate use of the terms energy shells, sub-shells and orbitals
- the reactions of the third period chlorides with water
- key definitions involving isomers
- the type of reactions involved in a variety of organic reactions along with the identification of suitable reagents and conditions.

There were instances where credit could not be awarded due to careless omissions and errors. Candidates are advised to check their responses carefully to make sure that any formulae given are correct and all equations are correctly balanced. Candidates should take care to avoid explanations containing direct contradictions.

## Comments on specific questions

### Question 1

- (a) (i) There were a small number of excellent explanations of *bond energy* in terms of the energy required to break one mole of bonds in gaseous molecules, however the majority of answers did not contain sufficient detail, with explanations only in terms of energy needed to break bonds.
- (ii) Many correct calculations were seen. Common mistakes included calculations of the N-H bond energy without any reference to the enthalpy change given for the formation of ammonia from nitrogen and hydrogen, incorrect expression of the equation *bonds broken* – *bonds made* = *enthalpy change* and use of incorrect stoichiometry.
- (b) (i) The shape of the curve produced at a higher temperature was well known and many correct, well drawn answers were seen. Some sketches did not clearly show the curve starting at the origin.
- (ii) The explanation for the effect of increasing temperature on reaction rate was generally well known and many answers explained the increase in rate in terms of the increased frequency of successful collisions. Some responses correctly stated that more molecules had energy greater than the activation energy. Confusion was occasionally evident where incorrect reference was made to a change in temperature affecting the activation energy.

- (iii) Many answers applied Le Chatelier's principle correctly and described the effect of increasing temperature on the yield of ammonia. Other responses did not include the idea that the changes in the position of equilibria occur as systems attempt to oppose any changes.
- (c) (i) Many responses showed correct calculation of the amounts of the gaseous reactants present in the equilibrium mixture. A common incorrect pair of answers, 0.7 and 2.7, was seen where the stoichiometry of the equation was ignored when calculating the amount of nitrogen and hydrogen gas present in the equilibrium sample.
- (ii) Many responses correctly calculated the partial pressure of ammonia in the equilibrium mixture using the values calculated in (i). In some responses confusion was apparent regarding how partial pressures are calculated; some answers attempted to use the ideal gas equation and others multiplied the amount of ammonia in the equilibrium mixture by the total pressure.
- (d) (i) Many correct answers were seen; common mistakes included either the omission of the partial pressure term or using square brackets to represent concentrations of the species. Occasionally the term given was the reciprocal of the correct answer.
- (ii) Correct calculations of  $K_p$  and stating its correct units, using the expression of  $K_p$  found in (i), were common. Identification of the correct units proved more challenging than calculating a value for  $K_p$ .
- (iii) Many answers correctly described the effect of reducing the volume on the yield of ammonia produced; fewer answers stated that this effect would have no change on the value of  $K_p$ .

## Question 2

- (a) (i) Many answers gave very good descriptions, explaining the general increase in ionisation energy across the third period in terms of increasing nuclear attraction due to an increasing nuclear charge and a similar shielding effect. Very few answers were seen that indicated that the slight increase in shielding was outweighed by the effects of increasing nuclear charge. There were some explanations that incorrectly identified the increasing size of atoms across a period.
- (ii) The correct approximate position of the ionisation energy of sodium on the graph was commonly seen; fewer answers demonstrated awareness that the first element of the series was in fact an inert gas and should have an appreciably higher ionisation energy than all the other elements shown.
- (iii) The correct location of the outermost electron in magnesium and aluminium was frequently given. The correct explanation for the decrease in ionisation energy, in terms of the effect of an increase in shielding caused by the s-subshell, was less common. The idea of electron pair repulsion caused by the pair of electrons sitting in a p-orbital was quite well known. Candidates should be familiar with the terms quantum shells, energy levels, subshells and orbitals and use these different terms in their correct contexts.
- (b) This question proved challenging for many. A comprehensive knowledge of the period three chlorides in terms of structure and bonding, and the effects of addition of water and sodium hydroxide on them were essential to enable the correct identification of **L** and **M**. Many answers simply repeated the information given in the question.

The reaction of silicon tetrachloride with water was well known, as was the identification of  $\text{HCl}$  as the acid fumes. Many responses correctly identified the simple molecular structure of the molecule to account for the low boiling point of **M**.

Some common mistakes included:

- incorrect formulae of magnesium chloride and silicon chloride
- sodium chloride identified as the white precipitate formed when magnesium chloride reacted with sodium hydroxide
- incorrectly balanced equations
- incorrect explanation of an approximately neutral solution of **L**, in terms of  $\text{MgCl}_2$ , reacting with water to make  $\text{HCl}$  and  $\text{Mg}(\text{OH})_2$ .

## Question 3



- (a) Reagents for the conversion of the bromoalkene to the alkene and the alcohol and the oxidation reactions of the alcohol and the aldehyde were generally well known. Some responses did not include the relevant conditions or gave incorrect conditions. The most common errors seen in this sequence of reactions were regarding reaction 3. Many answers described the reaction that would convert an aldehyde into a hydroxy-nitrile using hydrogen cyanide with potassium cyanide in an addition reaction. Some answers mistakenly identified reaction 4 as an oxidation reaction and described oxidising agents to carry out the reaction. The correct formula of the dichromate ion was not always seen when describing reactions 5 and 6.
- (b) The mechanism describing the  $S_N2$  mechanism of reaction 1 was well known. Care was taken by many to correctly show the position of the arrows used to describe the movement of electrons as bonds were made or broken and the correct dipole present on the C-Br bond.
- (c) (i) Many answers correctly defined the term structural isomer and named the three different types of structural isomer. A small number incorrectly described the structural isomers as the three geometrical isomers cis, trans and optical.
- (ii) The majority of answers identified the reaction mechanism as nucleophilic substitution. Many good explanations were given in terms of stability of the carbocation, either in terms of the inductive effect of the alkyl groups or in terms of steric hindrance. Some answers were confused and described the tertiary halogenoalkane as the carbocation.
- (d) (i) The description of stereoisomerism was less well known than the definition of structural isomers. Some answers were given in terms of the identification of the two types of stereoisomer rather than an explanation of the term.
- (ii) The majority of answers correctly stated that but-1-ene does not have a chiral carbon; many had difficulty expressing correctly why but-1-ene does not show geometrical isomerism, commonly resulting in ambiguous descriptions.
- (iii) This proved to be quite a demanding question. All the information given in the question was needed to deduce the correct structures of **X** and **Y** and name them appropriately. A significant number of answers were correct; some described **X**, by correctly stating the position of the chloro-group on 2-chlorobutane, and **Y** only as chloro-butane.
- (iv) In order to correctly identify the type of stereoisomerism shown in **X**, candidates needed to appreciate the chemical reaction involved when but-1-ene reacts with  $HCl$  to produce two structural isomers and that **X** exists as a pair of stereoisomers. Many correct answers were seen.
- (v) Many answers identified **X** as a chiral compound and represented the pair of stereoisomers in a correct 3-dimensional manner. The drawing of 3-dimensional representations of optical isomers requires care to be taken to show how the different atoms connect together in these structures and to ensure that two bonds drawn in the same plane i.e. as straight lines, are not shown at  $180^\circ$  to each other.

# CHEMISTRY

---

<p><b>Paper 9701/22</b> <b>AS Structured Questions</b></p>
--

## Key messages

Candidates are reminded to read questions carefully and check answers thoroughly, especially in extended answers where more writing is required. The accurate use of chemical terminology is welcomed, as it removes ambiguity from responses. Providing a clear statement of fact is crucial in the presentation of an argument.

Candidates are reminded to address 'explain' questions fully – not merely to state facts, but to go on to show how these combine to give reasons for chemical phenomena. This often requires a secure understanding of bonding and structure within molecules, in particular organic species.

Candidates are also reminded that their working in calculations should be shown to ensure that due credit can be awarded.

## General comments

Credit was awarded across the entire range of questions. Candidates tended to score more highly on questions that required recall of factual knowledge than those requiring application skills.

Scripts were generally clear and well presented. Candidates are advised to avoid writing in pencil and then overlaying this response with ink without rubbing out the pencil. Candidates should be able to write all answers in the spaces provided on the question paper.

## Comments on specific questions

### Question 1

- (a) Many candidates were awarded full credit for this question. 'Dot-and-cross' diagrams were not awarded credit, as they did not help to establish the shape of the molecules. Bond angles often contradicted the stated molecular shape.
- (b)(i) Candidates are reminded to be clear in distinguishing (covalent) bonds and (intermolecular) forces: some answers could not be awarded credit because of the suggestion that bonds were being broken in the melting of  $\text{SiCl}_4$ .
- (ii) This question was answered well by many candidates.
- (iii) Most answers to this question were correct. Some candidates did not show the lone pair on each chlorine atom.

## Question 2

- (a) The great majority of candidates answered this question correctly; some did not include a negative sign in the answers ( $-444$ ).
- (b)(i) Many candidates were unable to give a sufficiently clear or concise reason for a proposed increase in the rate of reaction.
- (ii) Candidates tended to give the same answer as in (b)(i). Examiners were looking for a simple response, stating an increase in the percentage decomposition, owing to the endothermic nature of the forward reaction.
- (c) This item required recall of physical chemistry. Candidates often did not include *rate* in their answer (e.g. 'When the forward and backward reactions are equal'); the conditions of a closed system or sealed container were similarly missed.
- (d)(i) Many candidates answered this well; a significant proportion ignored the contribution of  $PCl_3$  to the total pressure. The correct mole fraction of  $0.8/2.8$  was often given as  $0.8/2.0$  or even  $0.8/1.2$ .
- An answer calculated from values given later in (d)(iii) was also accepted.
- (ii) Candidates are reminded **not** to use square brackets in any expression using partial pressures, to avoid confusion with concentration.
- (iii) Many candidates were able to calculate this value correctly and use their expression in (d)(ii) to state the units as Pa.

## Question 3

- (a) It was clear that candidates understood the premise of this item but few were able to include sufficient key words for full credit to be awarded. Examiners were looking for references to shielding and the effect on the attraction of the nucleus for the outer-shell electrons.
- (b)(i) This question was answered well by many candidates.
- (ii) Many candidates gave confused answers to this question, seeking to justify the melting point decrease using the same argument as for decreasing ionisation energies down the group; the subtle differences were missed as a result.
- (c)(i) This question was answered well by many candidates.
- (ii) Many candidates made minor errors in their answers, which meant that full credit could not be awarded. It was not possible to award credit for BaO as a name, to avoid confusion with barium peroxide. All (symbol) equations provided needed to be balanced.
- (iii) This question was answered well by most candidates.
- (iv) Many candidates were able to identify the white solid/precipitate of either  $BaSO_4$  or  $Mg(OH)_2$ . Fewer candidates could correctly state the solubility (trend) of the Group II sulfate(s) or hydroxide(s).

#### Question 4

- (a) This question was answered well by many; candidates are reminded to include detail such as concentrated or (aq), as appropriate. Some answers included many conflicting types of reaction.
- (b) Many candidates were able to be awarded at least partial credit for the mechanism; care is required to show dipoles correctly and to position the tails and heads of (double-headed) curly arrows accurately.

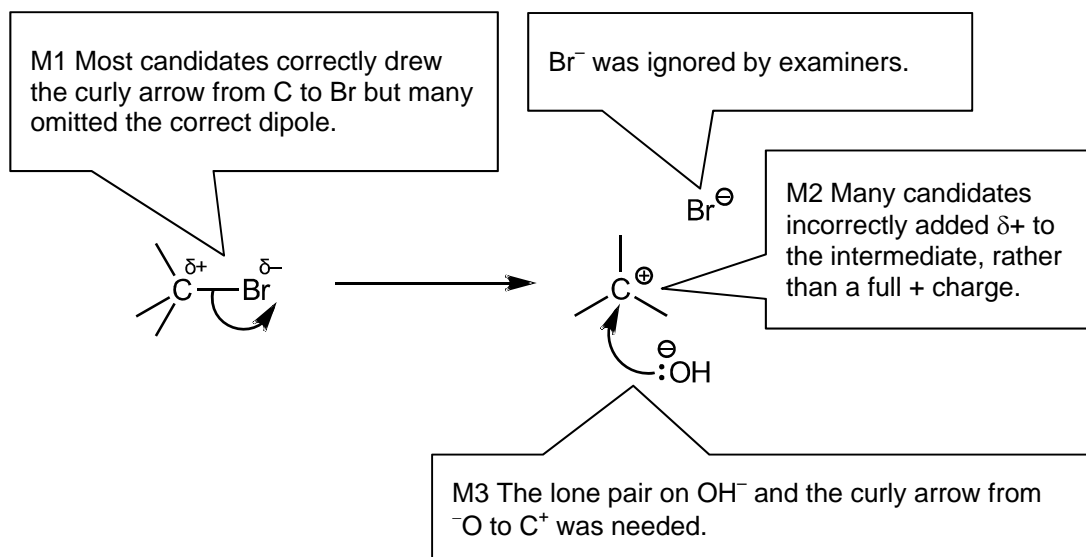

- (c) (i) Many candidates scored very well on this recall question.
- (ii) Candidates were largely able to identify the mechanism but the quality of explanation varied. A knowledge of structure of intermediates and the reasons for a difference in the positive inductive effect (+I) were required. An alternative approach, which considered the formation of an intermediate (stable compared to a transition state), was accepted.
- (d) (i) Candidates were able easily to identify that methylpropene contains no chiral centre; further detail was required in order for full credit to be awarded. Candidates are advised to refer to groups/atoms attached to the carbon atoms at each *end* of the double bond, rather than each side (an ambiguous term).
- (ii) A number of candidates were unable to show the repeat unit of methylpropene.
- (iii) Most candidates were awarded credit for this question.
- (e) There were many varied answers to this item. Candidates were required to give unambiguous names for each molecule which, if IUPAC systematic naming was employed, required the appropriate use of positional numbers.

# CHEMISTRY

---

Paper 9701/23  
AS Structured Questions

## Key messages

Candidates who performed well on this paper were able to:

- use specific vocabulary appropriately
- give correct formulae when identifying specific compounds and ions
- correctly balance equations.

## General comments

This paper proved to be straightforward for many candidates. Stronger responses demonstrated an excellent knowledge and understanding of the following:

- detailed explanations of the effect of temperature on both reaction rate and yield
- the trend in ionisation energy across a period with appropriate use of the terms energy shells, sub-shells and orbitals
- the reactions of the third period chlorides with water
- key definitions involving isomers
- the type of reactions involved in a variety of organic reactions along with the identification of suitable reagents and conditions.

There were instances where credit could not be awarded due to careless omissions and errors. Candidates are advised to check their responses carefully to make sure that any formulae given are correct and all equations are correctly balanced. Candidates should take care to avoid explanations containing direct contradictions.

## Comments on specific questions

### Question 1

- (a) (i) There were a small number of excellent explanations of *bond energy* in terms of the energy required to break one mole of bonds in gaseous molecules, however the majority of answers did not contain sufficient detail, with explanations only in terms of energy needed to break bonds.
- (ii) Many correct calculations were seen. Common mistakes included calculations of the N-H bond energy without any reference to the enthalpy change given for the formation of ammonia from nitrogen and hydrogen, incorrect expression of the equation *bonds broken* – *bonds made* = *enthalpy change* and use of incorrect stoichiometry.
- (b) (i) The shape of the curve produced at a higher temperature was well known and many correct, well drawn answers were seen. Some sketches did not clearly show the curve starting at the origin.
- (ii) The explanation for the effect of increasing temperature on reaction rate was generally well known and many answers explained the increase in rate in terms of the increased frequency of successful collisions. Some responses correctly stated that more molecules had energy greater than the activation energy. Confusion was occasionally evident where incorrect reference was made to a change in temperature affecting the activation energy.

- (iii) Many answers applied Le Chatelier's principle correctly and described the effect of increasing temperature on the yield of ammonia. Other responses did not include the idea that the changes in the position of equilibria occur as systems attempt to oppose any changes.
- (c) (i) Many responses showed correct calculation of the amounts of the gaseous reactants present in the equilibrium mixture. A common incorrect pair of answers, 0.7 and 2.7, was seen where the stoichiometry of the equation was ignored when calculating the amount of nitrogen and hydrogen gas present in the equilibrium sample.
- (ii) Many responses correctly calculated the partial pressure of ammonia in the equilibrium mixture using the values calculated in (i). In some responses confusion was apparent regarding how partial pressures are calculated; some answers attempted to use the ideal gas equation and others multiplied the amount of ammonia in the equilibrium mixture by the total pressure.
- (d) (i) Many correct answers were seen; common mistakes included either the omission of the partial pressure term or using square brackets to represent concentrations of the species. Occasionally the term given was the reciprocal of the correct answer.
- (ii) Correct calculations of  $K_p$  and stating its correct units, using the expression of  $K_p$  found in (i), were common. Identification of the correct units proved more challenging than calculating a value for  $K_p$ .
- (iii) Many answers correctly described the effect of reducing the volume on the yield of ammonia produced; fewer answers stated that this effect would have no change on the value of  $K_p$ .

## Question 2

- (a) (i) Many answers gave very good descriptions, explaining the general increase in ionisation energy across the third period in terms of increasing nuclear attraction due to an increasing nuclear charge and a similar shielding effect. Very few answers were seen that indicated that the slight increase in shielding was outweighed by the effects of increasing nuclear charge. There were some explanations that incorrectly identified the increasing size of atoms across a period.
- (ii) The correct approximate position of the ionisation energy of sodium on the graph was commonly seen; fewer answers demonstrated awareness that the first element of the series was in fact an inert gas and should have an appreciably higher ionisation energy than all the other elements shown.
- (iii) The correct location of the outermost electron in magnesium and aluminium was frequently given. The correct explanation for the decrease in ionisation energy, in terms of the effect of an increase in shielding caused by the s-subshell, was less common. The idea of electron pair repulsion caused by the pair of electrons sitting in a p-orbital was quite well known. Candidates should be familiar with the terms quantum shells, energy levels, subshells and orbitals and use these different terms in their correct contexts.
- (b) This question proved challenging for many. A comprehensive knowledge of the period three chlorides in terms of structure and bonding, and the effects of addition of water and sodium hydroxide on them were essential to enable the correct identification of **L** and **M**. Many answers simply repeated the information given in the question.

The reaction of silicon tetrachloride with water was well known, as was the identification of  $\text{HCl}$  as the acid fumes. Many responses correctly identified the simple molecular structure of the molecule to account for the low boiling point of **M**.

Some common mistakes included:

- incorrect formulae of magnesium chloride and silicon chloride
- sodium chloride identified as the white precipitate formed when magnesium chloride reacted with sodium hydroxide
- incorrectly balanced equations
- incorrect explanation of an approximately neutral solution of **L**, in terms of  $\text{MgCl}_2$ , reacting with water to make  $\text{HCl}$  and  $\text{Mg}(\text{OH})_2$ .

## Question 3

- (a) Reagents for the conversion of the bromoalkene to the alkene and the alcohol and the oxidation reactions of the alcohol and the aldehyde were generally well known. Some responses did not include the relevant conditions or gave incorrect conditions. The most common errors seen in this sequence of reactions were regarding reaction 3. Many answers described the reaction that would convert an aldehyde into a hydroxy-nitrile using hydrogen cyanide with potassium cyanide in an addition reaction. Some answers mistakenly identified reaction 4 as an oxidation reaction and described oxidising agents to carry out the reaction. The correct formula of the dichromate ion was not always seen when describing reactions 5 and 6.
- (b) The mechanism describing the  $S_N2$  mechanism of reaction 1 was well known. Care was taken by many to correctly show the position of the arrows used to describe the movement of electrons as bonds were made or broken and the correct dipole present on the C-Br bond.
- (c) (i) Many answers correctly defined the term structural isomer and named the three different types of structural isomer. A small number incorrectly described the structural isomers as the three geometrical isomers cis, trans and optical.
- (ii) The majority of answers identified the reaction mechanism as nucleophilic substitution. Many good explanations were given in terms of stability of the carbocation, either in terms of the inductive effect of the alkyl groups or in terms of steric hindrance. Some answers were confused and described the tertiary halogenoalkane as the carbocation.
- (d) (i) The description of stereoisomerism was less well known than the definition of structural isomers. Some answers were given in terms of the identification of the two types of stereoisomer rather than an explanation of the term.
- (ii) The majority of answers correctly stated that but-1-ene does not have a chiral carbon; many had difficulty expressing correctly why but-1-ene does not show geometrical isomerism, commonly resulting in ambiguous descriptions.
- (iii) This proved to be quite a demanding question. All the information given in the question was needed to deduce the correct structures of **X** and **Y** and name them appropriately. A significant number of answers were correct; some described **X**, by correctly stating the position of the chloro-group on 2-chlorobutane, and **Y** only as chloro-butane.
- (iv) In order to correctly identify the type of stereoisomerism shown in **X**, candidates needed to appreciate the chemical reaction involved when but-1-ene reacts with  $HCl$  to produce two structural isomers and that **X** exists as a pair of stereoisomers. Many correct answers were seen.
- (v) Many answers identified **X** as a chiral compound and represented the pair of stereoisomers in a correct 3-dimensional manner. The drawing of 3-dimensional representations of optical isomers requires care to be taken to show how the different atoms connect together in these structures and to ensure that two bonds drawn in the same plane i.e. as straight lines, are not shown at  $180^\circ$  to each other.

# CHEMISTRY

---

Paper 9701/31  
Advanced Practical Skills 1

## Key messages

- Candidates should be advised to read the questions carefully. Underlining or highlighting key words would help some provide appropriate answers.
- Candidates should be encouraged to read through their answers to ensure they use the subject-specific language with the precision expected at this level.
- Candidates should be encouraged to read through their observations for qualitative analysis questions to ensure they are not imprecise or ambiguous.
- Candidates should be instructed to complete the boxes relating to session and laboratory on the front of the paper unless a single laboratory was used for the whole entry from the centre.

## General comments

This paper proved accessible to all candidates. Almost all candidates completed the paper indicating that there were no apparent time constraints.

## Comments on specific questions

### Question 1

- (a) The standard of presentation of titration results was generally good. Most candidates gave appropriately labelled results to the correct level of precision and obtained concordant results. Whilst it was apparent that some candidates had less experience of titration exercises than others, almost all showed competence in carrying out the practical – this was tested by comparing the candidate's results with that of the relevant supervisor.

Candidates should be advised to only carry out enough titrations to demonstrate concordance.

- (b) Most candidates successfully showed how they arrived at a correct answer. Some did not include which accurate titrations were being used, included their rough titre, or did not give the answer correct to 2 decimal places.
- (c) Almost all candidates were able to calculate the number of moles of sodium thiosulfate correctly in (i) and many were able to use this to calculate the number of moles of iodine and iodine-containing compound in (ii) and (iii).

In (iv) the majority of candidates realised that it was necessary to divide (ii) by (iii) but a significant number did not give their answer as an integer.

Part (v) proved challenging with few candidates correctly inserting the number of moles of iodine from (iv) and then balancing the equation.

Even if they had not been able to obtain an answer to (v) a significant number of candidates showed that they could calculate oxidation states by using the default value of  $x$  given.



## Question 2

- (a) The majority of candidates gave acceptable descriptions of the appearance of **FA 5** when it was heated and then allowed to cool and most also recorded the correct number of balance readings in the space specified. Some of the headings in the results table were however unacceptable with 'weight' rather than 'mass' being used, the mass of the lid being specified in some readings but omitted in others and the 'mass of **FA 5** after heating' being given when the residue was in fact no longer **FA 5**.

Other answers did not include the mass of **FA 5** used and/or the mass of residue obtained whilst others appeared confused between the mass of residue and the mass lost during the heating.

- (b) Most candidates gave a correct  $M_r$  in (i) and also the expression for the  $M_r$  of the basic copper(II) carbonate in (ii). Many then went on to use this, and the mass of **FA 5**, to calculate the number of moles of basic copper(II) carbonate in (iii) with only a few attempting to produce a numerical answer.
- (iv) This part proved more challenging with few candidates realising that it was necessary to multiply the answer to (iii) by  $(1 + y)$ .
- (v) This was generally well done and although many realised that, to answer (vi) it was necessary to use (iv) = (v), a significant number did not give the final answer to one decimal place, as requested.
- (c) (i) Although vague answers, such as heat for longer/repeat the experiment were not acceptable, a number of candidates did give precise answers – generally these recognised the need to repeat the heating and weighing to reach constant mass.
- (ii) In this part it was also necessary to be precise so that the lower **percentage** error in **Experiment 1** had to be stated.

## Question 3

- (a) Most candidates drew a table showing observations for the two reagents specified with only a small minority including additional reagents.
- Many of the observations were correct although few candidates tested for the presence of  $\text{NH}_4^+$  by heating the unknowns with the aqueous sodium hydroxide. Some also omitted to add excess reagent in each case.
- (b) Most answers involved the use of aqueous silver nitrate but, as **FA 7** was a bromide, a precise description of the colour of the precipitate formed was needed.
- (c) (i) Most candidates used aluminium and aqueous sodium hydroxide although a number did not specify the need to heat the mixture and/or to include that the gas produced should be tested.
- (ii) Although this part proved challenging, a number of candidates recognised the need to use a mineral acid. If sulfuric acid was chosen then **FA 8** alone would give a white precipitate but for all acid reactions **FA 6** would give an effervescence of a pale brown gas whilst **FA 7** would not react. Other reagents, such as acidified potassium manganate(VII), were acceptable.

# CHEMISTRY

---

<p>Paper 9701/33 Advanced Practical Skills 1</p>
--

## Key messages

- Candidates should be advised to read the questions carefully. Underlining or highlighting key words would help some provide relevant and precise answers.
- Candidates should be encouraged to continue with other parts of the paper once they have obtained concordant accurate titres.
- Candidates should be encouraged to read through their observations for qualitative analysis questions to ensure they are not imprecise or ambiguous.
- Candidates should be instructed to complete the boxes relating to session and laboratory on the front of the paper unless a single laboratory was used for the whole entry from the Centre.

## General comments

This paper proved accessible to all candidates. Almost all candidates completed the paper, indicating that there were no time constraints. Practical work was generally completed to a high standard. Some parts of the calculations were well executed. Questions on errors and improvements were generally not well answered.

## Comments on specific questions

### Question 1

- (a) The standard of presentation of titration results was good. Most candidates were able to present appropriately labelled results to the correct level of precision and demonstrate concordant results. While it was apparent that some candidates had less experience of titration exercises than many others, almost all candidates were able to access at least partial credit for accuracy. Candidates showing greater facility with this technique were able to obtain concordance with two or three accurate titres.
- (b) Most candidates successfully showed how they arrived at a correct answer. Some did not indicate which accurate titres were being used, included their rough titre, or did not give the answer correct to two decimal places.
- (c) Almost all candidates were able to calculate the number of moles of thiosulfate ions correctly in (i). Some did not employ the 1:1 mole ratio in (ii) but went on to calculate the concentration correctly in (iii). Part (iv) proved more challenging for many.
- (d) Only a minority of candidates gained credit in (i). Common errors were omitting multiplying the error of  $\pm 0.05 \text{ cm}^3$  per reading by 2 and using the mean titre value. A precise answer was needed in the first part of (ii) that did not simply restate the question. Few candidates gained credit for the second marking point, indicating that the information that **FA 3** was in excess was ignored.

## Question 2

- (a) Most candidates tabulated their results successfully. The most common errors in the headings were to refer to the residue as 'FA 5 after heating' when FA 5 was denoted as hydrated barium chloride or to omit 'lid' from some of the balance readings. A significant minority of candidates confused mass of residue and mass of water lost. Only a few omitted 'mass' or mistakenly wrote 'weight'. The level of accuracy was high with most candidates gaining at least partial credit.
- (b) Most candidates answered well in this section. The most frequent error seen was not giving an integer value for  $y$ . For some, credit could not be awarded in (iii) because no working was shown or because an attempt was made to arrive at the expected answer of 2, even though the masses of residue and water lost had been exchanged in the table. A few incorrectly used 208 instead of 208.3 in (i).
- (c) While many candidates appeared to understand the problem posed in (i); fewer used sufficiently precise terminology to gain full credit; reference to mass or moles was needed. The majority of candidates wrote about re-heating the solid; fewer added the essential 'to constant mass'. Only a few received credit in (ii) by suggesting cooling the crucible and contents in a desiccator.

## Question 3

- (a) Many candidates were able to identify the presence of water of crystallisation in the two salts for part (ii). However, the observations in (i) often lacked precision; use of 'precipitate' instead of 'solid' or 'residue' was a common error. A large minority of candidates carried out gas tests on heating the solids; many of these mistakenly reported positive results with FA 6.
- (b) Part (i) was answered well by most candidates. Clear tables of tests and observations were produced and most gained credit for selecting suitable reagents and for their observations. The most common error was to describe the initial  $\text{Cu}(\text{OH})_2$  precipitate formed using  $\text{NH}_3(\text{aq})$  with FA 7 as dark blue. More careful observation would have distinguished the pale blue solid from the much darker blue solution. Only a few candidates omitted adding the reagents to excess, selected incorrect reagents or used unsuitable additional reagents. There were many good answers to (ii); some candidates should be made aware that 'no observation' or writing a dash are not acceptable alternatives to 'no (visible) reaction' or 'no (visible) change'. A significant number of candidates did not make it clear whether they were adding the excess of hydrochloric acid or nitric acid to a fresh sample of each unknown or to any precipitate formed with  $\text{Ba}^{2+}(\text{aq})$  ions. Some candidates ignored the instruction 'no additional test for ions present should be attempted' and went on to test the precipitate formed with  $\text{Ag}^+(\text{aq})$  ions with  $\text{NH}_3(\text{aq})$ . Most candidates were able to gain at least partial credit in (iii), with a sizable minority being awarded full credit through reporting supporting observations in (ii).

# CHEMISTRY

---

<p>Paper 9701/34 Advanced Practical Skills 2</p>
--

## Key messages

- Candidates should be advised to read the questions carefully. Underlining or highlighting key words would help some provide relevant and precise answers.
- Candidates should be encouraged to read through their answers to ensure they use the subject-specific language with the precision expected at this level.
- Candidates should be encouraged to read through their observations for qualitative analysis questions to ensure they are not imprecise or ambiguous.
- Candidates should be instructed to complete the boxes relating to session and laboratory on the front of the paper unless a single laboratory was used for the whole entry from the Centre.

## General comments

This paper proved accessible to all candidates. Almost all candidates completed the paper, indicating that there were no time constraints. Practical work was generally completed to a high standard. Questions on errors and improvements were generally not well answered.

## Comments on specific questions

### Question 1

- (a) A substantial number of candidates were awarded full credit in this section. Almost all candidates recorded results for five experiments and only a few ignored the instruction not to use less than  $10\text{cm}^3$  of **FB 1**. The most common errors in the table were an incorrect or missing unit for rate, not recording time to the nearest second and incorrect rounding of the rates. Almost all candidates gained credit for accuracy for increasing times with decreasing volumes of **FB1** and at least partial credit for self-consistency of results. It is particularly important that supervisors carry out rate experiments under the same conditions as the candidates as changes in room temperature will affect results.
- (b) A majority of candidates selected suitable scales and labelled the axes correctly. Those selecting complicated scales found it difficult when plotting the points. Some candidates plotted points on lines when they should have been between the grid lines and *vice versa* or drew blobs that occupied more than half a small square so did not have the required level of precision. Some did not circle clearly anomalous points and others circled all points plotted making it difficult to identify any they considered anomalous. Credit for the line of best fit could not be awarded when only two points were used or the distribution of the points was unbalanced.
- (c) A minority of candidates were awarded full credit in this section. Common errors were not drawing lines on the grid to show how the rate was obtained, drawing the 'horizontal' line to the nearest grid line and not converting the rate into time as required. Some candidates did not start the *y*-axis at zero and were unable to draw a suitable line on the graph. A few of these gained partial credit by indicating clearly on the graph how they were able to calculate the gradient and then successfully used  $y = mx + c$  to calculate the rate for  $8\text{cm}^3$  of **FB 1** used.

- (d) Only a minority of candidates gained more than half the credit available for this section. In (i), many incorrectly suggested that the change in shape of the reaction vessel would affect the rate of reaction. Many stated that the time taken would be longer; fewer stated that this was due to the decreased depth of the suspension and answered in terms of increased surface area and increased chance of collision. Many candidates correctly concluded that the time taken would increase; fewer gave an acceptable reason in (ii). Mention of a decrease in percentage error in timing was seen more frequently than a decrease in accuracy owing to the difficulty in judging exactly when the print was obscured.
- (e) Very few candidates realised that the error in a single reading of the time would be  $\pm 1$  s (or  $\pm 0.5$  s) and many used volume or rate in the denominator instead of the reaction time for **Experiment 1**.
- (f) Very few candidates were awarded full credit for this section. A common error was to suggest changing the concentration of **FB 2** and/or keeping the concentration of **FB 1** constant without stating how this could be achieved. Some candidates appeared to be confused by 'volume', 'amount' and 'concentration'. Only a small minority of candidates suggested that five (or more) experiments should be carried out or that the temperature needed to be constant.
- (g) Almost all candidates gained credit in (i), with some also labelling (0,0) on the diagram. Many candidates gained credit in (ii) but there were also some unaccountably strange shapes drawn. A line showing the rate rising from (0,0) to a plateau was a common incorrect answer.

## Question 2

- (a) Most candidates gained at least partial credit in (i). Some candidates should be made aware that 'no observation' or writing a dash are not acceptable alternatives to 'no (visible) reaction' or 'no (visible) change'. A common error was the confusion of colour on mixing **FB 4** and **FB 6**. More careful observation would have distinguished a pale blue precipitate from a darker blue solution. There was evidence from a few of the observations that the instruction to use a 1 cm depth of each solution was ignored by some. Only a minority of candidates correctly identified the anion as  $\text{OH}^-$  in (ii) and few went on to provide a simple test for the ion in (iii). Some suggested using the test for a nitrate but this was unsuitable unless it was clear that **FB 4** was not being added. Many received credit for a correct test in (v); slightly fewer recorded detailed correct observations.
- (b) Part (i) was answered well by most candidates with many gaining at least partial credit. One common error was not recording iodine being decolourised with **FB 7**. A common incorrect response was 'no change' or words to that effect. The reporting of precipitates, where none should have been encountered, was another common error together with some unacceptable colours such as red or orange reported for aqueous iodine. Some candidates ignored the instruction 'no additional test for ions present should be attempted' and went on to test the precipitate formed with  $\text{Ba}^{2+}(\text{aq})$  ions with a dilute acid. A large majority of candidates gained credit in (ii) for sulfate and sulfite ions. However, the test employed in (iii) often required more precision. Many candidates stated that hydrochloric or nitric acid should be added without adding a means of testing any gas evolved or making it clear to what they were adding the acid. They tended to go on to state the precipitate was insoluble in excess but adding acid to **FB 9** would not have produced a precipitate. Those suggesting adding acid to the precipitate formed with  $\text{Ba}^{2+}(\text{aq})$  often omitted the name of the acid or specified sulfuric acid and so did not receive credit.

# CHEMISTRY

---

**Paper 9701/35**  
**Advanced Practical Skills 1**

## Key messages

- Candidates should be advised to read the questions carefully. Underlining or highlighting key words would help some provide appropriate answers.
- Candidates should be encouraged to read through their answers to ensure they use the subject-specific language with the precision expected at this level.
- Candidates should be encouraged to read through their observations for qualitative analysis questions to ensure they are not imprecise or ambiguous.
- Candidates should be instructed to complete the boxes relating to session and laboratory on the front of the paper unless a single laboratory was used for the whole entry from the centre.

## General comments

This paper proved accessible to all candidates. Almost all candidates completed the paper indicating that there were no apparent time constraints.

## Comments on specific questions

### Question 1

- (a) The standard of presentation of titration results was generally good. Most candidates gave appropriately labelled results to the correct level of precision and obtained concordant results. Whilst it was apparent that some candidates had less experience of titration exercises than others, almost all showed competence in carrying out the practical – this was tested by comparing the candidate's results with that of the relevant supervisor.

Candidates should be advised to only carry out enough titrations to demonstrate concordance.

- (b) Most candidates successfully showed how they arrived at a correct answer. Some did not include which accurate titrations were being used, included their rough titre, or did not give the answer correct to 2 decimal places.
- (c) Almost all candidates were able to calculate the number of moles of sodium thiosulfate correctly in (i) and many were able to use this to calculate the number of moles of iodine and iodine-containing compound in (ii) and (iii).

In (iv) the majority of candidates realised that it was necessary to divide (ii) by (iii) but a significant number did not give their answer as an integer.

Part (v) proved challenging with few candidates correctly inserting the number of moles of iodine from (iv) and then balancing the equation.

Even if they had not been able to obtain an answer to (v) a significant number of candidates showed that they could calculate oxidation states by using the default value of  $x$  given.

## Question 2

- (a) The majority of candidates gave acceptable descriptions of the appearance of **FA 5** when it was heated and then allowed to cool and most also recorded the correct number of balance readings in the space specified. Some of the headings in the results table were however unacceptable with 'weight' rather than 'mass' being used, the mass of the lid being specified in some readings but omitted in others and the 'mass of **FA 5** after heating' being given when the residue was in fact no longer **FA 5**.

Other answers did not include the mass of **FA 5** used and/or the mass of residue obtained whilst others appeared confused between the mass of residue and the mass lost during the heating.

- (b) Most candidates gave a correct  $M_r$  in (i) and also the expression for the  $M_r$  of the basic copper(II) carbonate in (ii). Many then went on to use this, and the mass of **FA 5**, to calculate the number of moles of basic copper(II) carbonate in (iii) with only a few attempting to produce a numerical answer.
- (iv) This part proved more challenging with few candidates realising that it was necessary to multiply the answer to (iii) by  $(1 + y)$ .
- (v) This was generally well done and although many realised that, to answer (vi) it was necessary to use (iv) = (v), a significant number did not give the final answer to one decimal place, as requested.
- (c) (i) Although vague answers, such as heat for longer/repeat the experiment were not acceptable, a number of candidates did give precise answers – generally these recognised the need to repeat the heating and weighing to reach constant mass.
- (ii) In this part it was also necessary to be precise so that the lower **percentage** error in **Experiment 1** had to be stated.

## Question 3

- (a) Most candidates drew a table showing observations for the two reagents specified with only a small minority including additional reagents.
- Many of the observations were correct although few candidates tested for the presence of  $\text{NH}_4^+$  by heating the unknowns with the aqueous sodium hydroxide. Some also omitted to add excess reagent in each case.
- (b) Most answers involved the use of aqueous silver nitrate but, as **FA 7** was a bromide, a precise description of the colour of the precipitate formed was needed.
- (c) (i) Most candidates used aluminium and aqueous sodium hydroxide although a number did not specify the need to heat the mixture and/or to include that the gas produced should be tested.
- (ii) Although this part proved challenging, a number of candidates recognised the need to use a mineral acid. If sulfuric acid was chosen then **FA 8** alone would give a white precipitate but for all acid reactions **FA 6** would give an effervescence of a pale brown gas whilst **FA 7** would not react. Other reagents, such as acidified potassium manganate(VII), were acceptable.

# CHEMISTRY

---

<p><b>Paper 9701/36</b> <b>Advanced Practical Skills 2</b></p>
--

## Key messages

- Candidates should be advised to read the questions carefully. Underlining or highlighting key words would help some provide appropriate answers.
- Candidates should be encouraged to read through their answers to ensure they use the subject-specific language with the precision expected at this level.
- Candidates should be encouraged to read through their observations for qualitative analysis questions to ensure they are not imprecise or ambiguous.
- Candidates should be instructed to complete the boxes relating to session and laboratory on the front of the paper unless a single laboratory was used for the whole entry from the centre.
- Candidates should be reminded that in qualitative analysis, if a gas is evolved, a test should be carried out to identify the gas.

## General comments

This paper proved accessible to all candidates. Almost all candidates completed the paper indicating that there were no apparent time constraints.

## Comments on specific questions

### Question 1

- (a) The standard of presentation of titration results was generally good. Most candidates gave appropriately labelled results to the correct level of precision and obtained concordant results. Whilst it was apparent that some candidates had less experience of titration exercises than others, almost all showed competence in carrying out the practical – this was tested by comparing the candidate's results with those of the relevant supervisor.

Candidates should be advised to only carry out enough titrations to demonstrate concordance.

- (b) Most candidates successfully showed how they arrived at a correct answer. Some did not include which accurate titrations were being used, included their rough titre, or did not give the answer correct to 2 decimal places.
- (c) Almost all candidates were able to calculate the number of moles of manganate(VII) ions correctly in (i) and many were able to use this, and the stoichiometry of the equation, to calculate the number of moles of ethanedioate ions in (ii).
- (d) Although a number of correct equations were seen, some candidates omitted (or gave incorrect) state symbols. Another relatively common error was in writing an incorrect formula for sodium ethanedioate.
- (e), (f) Most candidates again showed that they are generally competent in carrying out titrations and in interpreting straightforward moles-based calculations.
- (g)(i) This calculation was less well done with some candidates multiplying or adding the moles involved. Others, who had incorrect numbers of moles, reversed the subtraction in an attempt to give a positive answer.



- (ii)(iii) Credit could not be awarded when incorrect  $M_r$  values were used or for answers that were not to a suitable number of decimal places but, in general, it was evident that most candidates understood the basis of the calculations involved.
- (iv) Many correct answers were seen although a significant number of candidates did not include both masses in the denominator of the expression for the percentage.
- (h) In each case there were several ways in which this explanation could be expressed but it had to be precise in addressing the stated effect. In (i) the use of either formula would not affect the titration value whilst in (ii) it was acceptable to argue that the percentage would increase or decrease as long as the suggestion was justified by the explanation.
- (i) Some precision of response was required in that it was necessary to comment on the effect of the change on the **percentage** error.

## Question 2

- (a) Most candidates gave correct observations when aqueous sodium hydroxide was used although some did not include the observation when excess reagent was used. In (i) and again in (d) a number of candidates stated that a gas was given off but did not identify the gas.
- In (iv) it was necessary to include the initial colour of the manganate(VII) and in (vi) to include a precise description of the colour when iodine is produced. This is generally described as being yellow/ brown whilst the starch/ iodine complex is described as being blue-black or black or dark blue.
- (b) Since the question asked for the metal present it was not, in this case, necessary to include the relevant oxidation state.
- (c) Few candidates gave an acceptable ionic equation.
- (d)(i) As noted above a number of responses clearly showed that a gas was being formed but few candidates identified the gas.
- (ii) For the award of credit it was necessary to describe the formation of a green solution.
- (e) Most candidates realised that it was necessary to use  $\text{Ba}^{2+}(\text{aq})$  and  $\text{Ag}^+(\text{aq})$  but a significant number did not include the full name/formula of the reagent, did not use a named mineral acid or used sulfuric acid (even though one possible identity of the unknown was a sulfate).

# CHEMISTRY

---

**Paper 9701/41**  
**A Level Structured Questions**

## Key messages

- Candidates need to show clear working in mathematical questions as where a final answer is incorrect often credit can be obtained for correct working.
- Candidates should ensure they read the questions carefully so that the question is answered as it has been set.

## General comments

This paper gave candidates of all abilities the opportunity to demonstrate their knowledge and understanding of a wide range of chemistry topics. Candidates who had prepared well for the examination were able to attempt all of the questions. There was no evidence of candidates being short of time.

This report should be read in conjunction with the published mark scheme for this paper, which offers accepted answers to the questions.

## Comments on specific questions

### Section A

#### Question 1

- (a) This was well answered. A variety of incorrect oxidation numbers were seen for N and Br.
- (b) This question discriminated well. Many candidates showed that nitrogen was the central atom with three shared pairs of electrons. Common errors included omission of non-bonding electrons or showing the divalent nitrogen atom with a dative covalent bond. Only a few examples of ionic bonding were seen.
- (c) (i) The overall order was sometimes correctly described. Many candidates did not refer to the rate equation. The description of a power was often missing.
- (ii) This was well answered. Many candidates recognised the reaction was second order for NO and first order for Br<sub>2</sub>. However, some did not clearly explain their evidence by linking to the experimental data.
- (iii) Some candidates did not realise that this could be deduced using simple ratios.
- (iv) Most candidates were able to evaluate a rate constant.
- (v) This question was challenging for most candidates who did not show understanding of the effect of *k* in the rate equation. A common error was a discussion in terms the effect of temperature using collision theory.
- (d) This was found difficult by candidates. Candidates often gave the stoichiometric ratio of X and Y of  $m = 2$  and  $n = 1$ .

### Question 2

- (a) Many candidates did not use the  $K_{sp}$  data to describe the trend in solubility of the Group 2 carbonates.
- (b)(i) This was generally well answered.
- (ii) This was usually well known but some candidates did not explain the 'common ion effect'.
- (c) Many fully correct answers were seen although some candidates calculated the molar concentration of  $MgCO_3$  ( $3.16 \times 10^{-3} \text{ mol dm}^{-3}$ ) and did not convert this to  $g \text{ dm}^{-3}$ .
- (d)(i) Many candidates gave a clear explanation here.
- (ii) Most candidates gave the correct answer here. A common error was using  $BaNO_3$  rather than  $Ba(NO_3)_2$ .
- (iii) The equations were generally correct.

### Question 3

- (a) Many candidates confused the definition of the standard cell potential with the standard electrode potential. Some did not point out that to measure the *standard* cell potential, gases need to be at 1 atm and solutions need to be at  $1 \text{ mol dm}^{-3}$ .
- (b)(i) Most candidates answered this question well.
- (ii) There were some good answers here although many candidates found it difficult to process the information given in the question. The explanation often did not link to the  $Pb^{2+}/Pb$  half-equation.
- (c)(i) Many candidates gained partial credit here.
- (ii) The equation was often not well answered.
- (d) Many candidates answered this question well. Common errors included  $H_2$  and  $O_2$  being regenerated as it was an equilibrium reaction, or they are in plentiful supply from the atmosphere.

### Question 4

- (a) Many candidates performed well here.
- (b) This was generally well known.
- (c)(i) Most candidates gave the correct answer.
- (ii) Many fully correct answers were seen.
- (iii) Most candidates answered this correctly.
- (iv) Many candidates found this challenging.
- (d) This question discriminated well. A variety of chemical tests were seen. Common errors included use of  $NaOH(aq)$ ,  $Pb^{2+}(aq)$  and  $NH_3$  alone.
- (e) Many candidates answered this question well. A common error was stating this was due to different amounts of energy being absorbed.
- (f) This was well known.

### Question 5

- (a) Many candidates gained partial credit. This question required the candidates to name all the functional groups in **P** and often one or two groups were omitted.
- (b) This was well answered. Many candidates gave clear, well-drawn structures.
- (c) This proved difficult for many candidates. Only a few candidates were awarded full credit here. Common errors included:
- substitution with Br on the benzene ring;
  - formation of 2-chlorobenzaldehyde with excess hot, concentrated  $\text{MnO}_4^-$ ;
  - addition of HCl across the C=C bond;
  - omission of hydrogenation of the benzene ring or CN group with  $\text{H}_2$ .

### Question 6

- (a) (i) Most candidates identified the correct by-product.
- (ii) This was well answered.
- (iii) Many candidates found this challenging and often described the differences on a superficial level such as intermediate **T** contains a positive charge unlike methylbenzene. Candidates could have described the differences in terms of:
- extent of delocalisation of the ring;
  - number of p-electrons in the delocalised system;
  - hybridisation;
  - bond angles/C-C bond lengths or strengths/shape around the carbons.
- (b) (i) This proved difficult for many candidates.
- (ii) This was only answered well by stronger candidates. The most common errors were to:
- omit concentrated or heat in step 1;
  - use  $\text{AlCl}_3$  or aqueous conditions in step 2;
  - omit heating in step 3, 4 and 5;
  - use aqueous  $\text{H}_2\text{SO}_4$  in step 5.
- (c) This was generally well answered. Some omitted sufficient detail about the lone pair on the nitrogen being less available to protonation or donation.
- (d) (i) Many candidates found this difficult. A common incorrect answer was five peaks. This is the number of different proton environments in the proton NMR spectrum.
- (ii) This was usually well known but some candidates confused this with the exchange of labile protons.
- (iii) This was well answered. Common errors were to:
- assign  $\text{C}_6\text{H}_5\text{NH}_2$  to  $\delta$  5.5 and not clearly specify this was due to the  $\text{NH}_2$  protons;
  - assign more than eleven protons (in total) to the four absorptions in the proton NMR spectrum.
- (iv) This was well known. Some candidates did not refer to 'adjacent (carbon) atom'. The answer 'two adjacent protons' was not sufficient.
- (v) Many candidates identified that the  $\text{NH}_2$  peak would disappear, however they did not clearly explain their answer in terms of proton exchange. Some incorrectly stated that there would be no change as the molecule does not contain an OH group.
- (e) (i) This was well known.
- (ii) This was answered well by many candidates. Common errors were to:
- use the OH group in the coupling;
  - use  $\text{N}\equiv\text{N}$  in compound **S**.

### Question 7

- (a) Most candidates gave the correct answer here.
- (b) This was answered well by many candidates. A common error was 3.65 where no square root had been taken.
- (c) (i) This was less well known. Many described  $K_{\text{stab}}$  in terms of stability of the complex but did not relate to an equilibrium constant.
- (ii) Most candidates found this challenging. Many did not use the information in the question.
- (d) This was answered well by many candidates. Some candidates made careless errors, such as ionic charges outside the final square brackets. Units should be given as, for example,  $\text{mol}^{-2} \text{dm}^6$ , and should not be left in a form that requires further simplification, for example  $(\text{mol dm}^{-3})^{-2}$ .
- (e) (i) Most candidates drew clear diagrams. Some candidates' answers showed two or three identical structures, rather than three stereoisomers.
- (ii),(iii),(iv) These parts were generally well answered.

# CHEMISTRY

---

**Paper 9701/42**  
**A Level Structured Questions**

## Key messages

Candidates need to ensure that corrected work is clear to read; work that is crossed out should be very clearly crossed out, and never overwritten with the new answer. Many examples of unclear handwriting were seen. Clear, definite and unambiguous answers are essential.

Candidates need to show clear working in mathematical questions as where a final answer is incorrect often credit can be obtained for correct working.

## General comments

Many excellent scripts were seen on which the candidates showed a thorough grasp of the chemistry required and expressed their knowledge clearly and unambiguously.

The majority of candidates demonstrated use of appropriate mathematical skills. A minority of candidates could not be awarded credit because of incorrect rounding of answers. Some candidates rounded at more than one stage during a calculation, for example rounding the intermediate answer in **Q2(a)(ii)** to 0.02 moles, which generated an incorrect final answer.

## Comments on specific questions

### Question 1

- (a) Good answers included correctly worked out oxidation states of chlorine. Common errors included incorrect oxidation states of sodium, such as +5, and an oxidation state of -3 for chlorine in  $\text{NaClO}_2$ .
- (b) Candidates should have ensured that diagrams involved 19 outer electrons; many did not.
- (c) (i) Many candidates gave a precise answer.
- (ii) This was usually answered well. Candidates should ensure that answers such as  $\text{s}^{-1}/(\text{mol dm}^{-3})$  are written as  $\text{mol}^{-1} \text{dm}^3 \text{s}^{-1}$ .
- (iii) This was generally answered well.
- (d) (i) Many candidates gave a precise answer.
- (ii) Some candidates found this challenging. Credit was awarded for a slow step with  $\text{F}_2$  and  $\text{ClO}_2$  as the only reactants. Better performing candidates made this slow step the first step of the suggested mechanism. The further credit was awarded if the two steps added up to the balanced chemical equation given in the question.
- (e) Many answers focussed on collision frequency and energy; very few described the effect on the rate constant.

## Question 2

- (a) (i) This was usually correctly answered. Some candidates did not realise that the reference to an alkaline gas indicated ammonia.
- (ii) This was generally answered well.
- (b) Many candidates had learned this material well and described it clearly. A significant number of candidates gave answers with no reference to  $\Delta H$  values and therefore could not be awarded credit.
- (c) (i) This was generally answered well although many expressions were seen that included  $[\text{Mg}(\text{OH})_2]$ .
- (ii) The most common error was not to realise that the concentration of hydroxide ions is twice the concentration of magnesium ions.
- (d) This was generally answered well. A significant number of candidates described 'decreasing polarising power' down the group, without stating clearly what is being polarised. In this case, it is the hydroxide anion that is polarised. Many answers were seen that referred to charge density in a correct manner but did not receive credit because there was no recognition that variation in charge density is entirely due to the variation in ionic radius.

## Question 3

- (a) (i) Candidates found this question challenging. At pH 1 the tryptophan will exist as a 1+ or 2+ ion; at pH 5.9 it will exist as a zwitterion with no overall charge.
- (ii) Many correct, accurately drawn dipeptides were seen. The most common errors included the drawing of tripeptides and the formation of six membered rings using the  $\text{NH}_2$  groups and the  $\text{COOH}$  groups on both amino acids.
- (b) Full credit was seldom awarded for this question. The table includes common incorrect responses:

Na	writing the ion with a – or a + charge but not both and calling this a neutralisation reaction
excess $\text{Br}_2(\text{aq})$	not realising that the phenol would undergo electrophilic substitution
excess $\text{CH}_3\text{COCl}$	not appreciating that both the phenolic OH and the $\text{NH}_2$ group will undergo a condensation reaction or acylating the benzene ring; this will not happen in the absence of $\text{AlCl}_3$
excess $\text{H}_2/\text{Pt}$ catalyst	not hydrogenating both the $\text{C}=\text{C}$ and the benzene ring

- (c) (i) This was generally answered well.
- (ii) The concept of labile protons in NH or OH groups that are replaced by D was understood and explained well by approximately half the candidates.
- (d) It was rare to see an answer that recognised that an ester bond can be hydrolysed.

## Question 4

- (a) (i) Most candidates were awarded credit here.
- (ii) Credit was usually awarded here; answers were seen in which both species were oxidised, or both reduced, or where at least one ionic charge was omitted.

- (iii) The 'salt bridge and voltmeter' and the ' $V^{3+}/V^{2+}$ ' marking points were usually credited. Some candidates did not label their electrodes, or thought one electrode was made of vanadium. The ' $VO_2^+/VO^{2+}/H^+$ ' marking point was very rarely awarded due to no mention of  $H^+$ .
- (b) Many candidates found this to be challenging. A common error seen was the  $E_{\text{cell}}^{\ominus}$  and a balanced chemical equation for the reaction between  $Sn^{4+}$  ions and vanadium metal, rather than the reaction between  $Sn^{4+}$  ions and  $V^{2+}$  ions, as in the question.

#### Question 5

- (a) Some candidates stated that the co-ordination number in octahedral geometry is eight.
- (b) This question was generally well answered.
- (c) (i) Full credit was awarded to a significant proportion of candidates. Other candidates made errors which included:
- using the second ionisation energy of magnesium, 1450
  - not using the bond energy of chlorine, 242
  - not halving the bond energy of chlorine
  - arithmetic and sign errors.
- (ii) This question was not well answered overall. Many candidates wrongly deduced that  $MgCl$  contains  $Mg^{2+}$  ions and thus predicted  $MgCl$  has the more exothermic lattice energy when compared to  $NaCl$ .
- (d) Many candidates gave a precise answer.

#### Question 6

- (a) Some candidates knew the definition in the syllabus and so received credit.
- (b) This question discriminated well.
- (c) It is recommended that candidates use the form of 3-D bonds shown in the syllabus. Although this is not mandatory, it does help to avoid errors. The drawing of an 'equatorial plane' was not considered enough to show 3-D in the absence of 3-D bonds. Some candidates drew two cis isomers or two trans isomers and so were awarded partial credit.
- (d) The majority of candidates received credit here.
- (e) Candidates found this question to be challenging. It was rare for full credit to be awarded.
- (f) This question was well answered and full credit was often awarded. The most common errors were:
- no label or other use of the term 'active site'
  - labelling the active site on the substrate
  - no recognition of product release
  - not recognising that a breakdown reaction was required
  - confusing enzyme catalysis with heterogeneous catalysis on a metal surface.



### Question 7

- (a) (i) This equation was correct on many scripts. CaO was a common error in the products.
- (ii) Many correct answers were seen; a large number of diagrams did not include a total of ten outer electrons, four from each carbon atom plus two for the 2- charge.
- (b) This question discriminated well.
- (c) (i) Many candidates could not be awarded credit for answers that did not use precise chemical vocabulary.
- (ii) This question discriminated well. Many answers were seen that were not empirical formulae, such as C<sub>2</sub>H<sub>2</sub> and (CH)<sub>n</sub>.
- (iii) Properties that are also properties of metals, such as 'good conductor of electricity', or 'durable' could not be awarded credit.
- (d) (i) Some diagrams were carelessly drawn. For example, credit could not be awarded where the two ends of a dipole were labelled δ- and δ-, or + and - without use of the δ sign. Curly arrows represent the movement of two electrons, therefore they must begin on a lone pair or a bond, they cannot begin on a minus charge or on an atom. It was very difficult to discern whether or not some of the intermediates were drawn with a minus charge.
- For this question, the reacting species were drawn on the left and candidates were expected to use the two species drawn here as starting points for the relevant curly arrows, and were also expected to label the dipole on the C=O bond here. The box in the middle of the mechanism is intended for the structure of the intermediate. If candidates did not use the layout on the question paper they could still receive full credit, but it was possibly a more difficult task.
- (ii) Candidates who could draw the mechanism in (i) usually gained credit here.
- (iii) This question discriminated well.
- (e) Candidates generally answered well here. It was noticeable that the redox reactions of ethanal and propanone are better known than those of methanoic acid and ethanedioic acid.

### Question 8

- (a) (i) The instruction to draw a line through bonds giving rise to geometrical isomerism was not well understood.
- (ii) Many candidates gained credit here but precise terms were not always used. For example, 'ketone' received credit; 'carbonyl' did not, as this includes aldehydes
- (iii) This question discriminated well.
- (iv) This discriminated well. Common errors included the carbonyl group drawn on the wrong carbon atom in either or both of Y and Z.
- (b) (i) This question discriminated well.
- (ii) This was not well answered. The importance of interactions between the stationary phase and the compounds J, K and L was often not well described. Some candidates stated that the substances were separating on the basis of difference in molecular mass.
- (iii) Many answers were seen that were awarded credit. Many careless and imprecise answers were also seen. Such answers included:
- phrases like 'distance of solute', rather than 'distance travelled by solute' or 'distance of solute from the starting line'
  - no clear statement of which distance is divided by which distance.

# CHEMISTRY

---

**Paper 9701/43**  
**A Level Structured Questions**

## Key messages

- Candidates need to show clear working in mathematical questions as where a final answer is incorrect often credit can be obtained for correct working.
- Candidates should ensure they read the questions carefully so that the question is answered as it has been set.

## General comments

This paper gave candidates of all abilities the opportunity to demonstrate their knowledge and understanding of a wide range of chemistry topics. Candidates who had prepared well for the examination were able to attempt all of the questions. There was no evidence of candidates being short of time.

This report should be read in conjunction with the published mark scheme for this paper, which offers accepted answers to the questions.

## Comments on specific questions

### Section A

#### Question 1

- (a) This was well answered. A variety of incorrect oxidation numbers were seen for N and Br.
- (b) This question discriminated well. Many candidates showed that nitrogen was the central atom with three shared pairs of electrons. Common errors included omission of non-bonding electrons or showing the divalent nitrogen atom with a dative covalent bond. Only a few examples of ionic bonding were seen.
- (c) (i) The overall order was sometimes correctly described. Many candidates did not refer to the rate equation. The description of a power was often missing.
- (ii) This was well answered. Many candidates recognised the reaction was second order for NO and first order for Br<sub>2</sub>. However, some did not clearly explain their evidence by linking to the experimental data.
- (iii) Some candidates did not realise that this could be deduced using simple ratios.
- (iv) Most candidates were able to evaluate a rate constant.
- (v) This question was challenging for most candidates who did not show understanding of the effect of *k* in the rate equation. A common error was a discussion in terms the effect of temperature using collision theory.
- (d) This was found difficult by candidates. Candidates often gave the stoichiometric ratio of X and Y of  $m = 2$  and  $n = 1$ .

### Question 2

- (a) Many candidates did not use the  $K_{sp}$  data to describe the trend in solubility of the Group 2 carbonates.
- (b)(i) This was generally well answered.
- (ii) This was usually well known but some candidates did not explain the 'common ion effect'.
- (c) Many fully correct answers were seen although some candidates calculated the molar concentration of  $MgCO_3$  ( $3.16 \times 10^{-3} \text{ mol dm}^{-3}$ ) and did not convert this to  $g \text{ dm}^{-3}$ .
- (d)(i) Many candidates gave a clear explanation here.
- (ii) Most candidates gave the correct answer here. A common error was using  $BaNO_3$  rather than  $Ba(NO_3)_2$ .
- (iii) The equations were generally correct.

### Question 3

- (a) Many candidates confused the definition of the standard cell potential with the standard electrode potential. Some did not point out that to measure the *standard* cell potential, gases need to be at 1 atm and solutions need to be at  $1 \text{ mol dm}^{-3}$ .
- (b)(i) Most candidates answered this question well.
- (ii) There were some good answers here although many candidates found it difficult to process the information given in the question. The explanation often did not link to the  $Pb^{2+}/Pb$  half-equation.
- (c)(i) Many candidates gained partial credit here.
- (ii) The equation was often not well answered.
- (d) Many candidates answered this question well. Common errors included  $H_2$  and  $O_2$  being regenerated as it was an equilibrium reaction, or they are in plentiful supply from the atmosphere.

### Question 4

- (a) Many candidates performed well here.
- (b) This was generally well known.
- (c)(i) Most candidates gave the correct answer.
- (ii) Many fully correct answers were seen.
- (iii) Most candidates answered this correctly.
- (iv) Many candidates found this challenging.
- (d) This question discriminated well. A variety of chemical tests were seen. Common errors included use of  $NaOH(aq)$ ,  $Pb^{2+}(aq)$  and  $NH_3$  alone.
- (e) Many candidates answered this question well. A common error was stating this was due to different amounts of energy being absorbed.
- (f) This was well known.

### Question 5

- (a) Many candidates gained partial credit. This question required the candidates to name all the functional groups in **P** and often one or two groups were omitted.
- (b) This was well answered. Many candidates gave clear, well-drawn structures.
- (c) This proved difficult for many candidates. Only a few candidates were awarded full credit here. Common errors included:
- substitution with Br on the benzene ring;
  - formation of 2-chlorobenzaldehyde with excess hot, concentrated  $\text{MnO}_4^-$ ;
  - addition of HCl across the C=C bond;
  - omission of hydrogenation of the benzene ring or CN group with  $\text{H}_2$ .

### Question 6

- (a) (i) Most candidates identified the correct by-product.
- (ii) This was well answered.
- (iii) Many candidates found this challenging and often described the differences on a superficial level such as intermediate **T** contains a positive charge unlike methylbenzene. Candidates could have described the differences in terms of:
- extent of delocalisation of the ring;
  - number of p-electrons in the delocalised system;
  - hybridisation;
  - bond angles/C-C bond lengths or strengths/shape around the carbons.
- (b) (i) This proved difficult for many candidates.
- (ii) This was only answered well by stronger candidates. The most common errors were to:
- omit concentrated or heat in step 1;
  - use  $\text{AlCl}_3$  or aqueous conditions in step 2;
  - omit heating in step 3, 4 and 5;
  - use aqueous  $\text{H}_2\text{SO}_4$  in step 5.
- (c) This was generally well answered. Some omitted sufficient detail about the lone pair on the nitrogen being less available to protonation or donation.
- (d) (i) Many candidates found this difficult. A common incorrect answer was five peaks. This is the number of different proton environments in the proton NMR spectrum.
- (ii) This was usually well known but some candidates confused this with the exchange of labile protons.
- (iii) This was well answered. Common errors were to:
- assign  $\text{C}_6\text{H}_5\text{NH}_2$  to  $\delta$  5.5 and not clearly specify this was due to the  $\text{NH}_2$  protons;
  - assign more than eleven protons (in total) to the four absorptions in the proton NMR spectrum.
- (iv) This was well known. Some candidates did not refer to 'adjacent (carbon) atom'. The answer 'two adjacent protons' was not sufficient.
- (v) Many candidates identified that the  $\text{NH}_2$  peak would disappear, however they did not clearly explain their answer in terms of proton exchange. Some incorrectly stated that there would be no change as the molecule does not contain an OH group.
- (e) (i) This was well known.
- (ii) This was answered well by many candidates. Common errors were to:
- use the OH group in the coupling;
  - use  $\text{N}\equiv\text{N}$  in compound **S**.

### Question 7

- (a) Most candidates gave the correct answer here.
- (b) This was answered well by many candidates. A common error was 3.65 where no square root had been taken.
- (c) (i) This was less well known. Many described  $K_{\text{stab}}$  in terms of stability of the complex but did not relate to an equilibrium constant.
- (ii) Most candidates found this challenging. Many did not use the information in the question.
- (d) This was answered well by many candidates. Some candidates made careless errors, such as ionic charges outside the final square brackets. Units should be given as, for example,  $\text{mol}^{-2} \text{dm}^6$ , and should not be left in a form that requires further simplification, for example  $(\text{mol dm}^{-3})^{-2}$ .
- (e) (i) Most candidates drew clear diagrams. Some candidates' answers showed two or three identical structures, rather than three stereoisomers.
- (ii),(iii),(iv) These parts were generally well answered.

# CHEMISTRY

**Paper 9701/51**  
**Planning, Analysis and Evaluation**

## General comments

Even though this is an alternative to practical paper the more chemistry practical that has been performed or seen aids success in an examination of this nature. Familiarity with chemical apparatus gives an appreciation of suitable types and sizes to be used for given procedures.

The introduction to each question often gives relevant information, which should be used as an aid to answering the questions.

Setting out calculations in a clear, logical order is encouraged, along with suitable labelling.

Often calculators produce values as vulgar fractions, which are acceptable only during the course of a calculation but not as a final answer, which needs to be in decimal or standard form to the required significant figures or decimal places. Early or over rounding should be avoided during the course of a calculation; final answers should be correctly rounded and not truncated.

Mass values should be quoted to the same number of decimal places as the data from which they are derived (usually two) and with a mass unit. Similarly, completing data in tables should be continued to the same number of decimal places as any initial data in that table.

Some candidates tend to over answer, providing multiple responses to a question that only requires one answer. This can result in contradictions, which negate correct answers. Candidates should be encouraged to directly respond to each individual question in a straightforward way.

## Comments on specific questions

### Question 1

- (a) (i) Most candidates answered this correctly. Common errors were to calculate the number of moles or the  $M_r$  incorrectly. There was also some incorrect rounding or answers recorded to only two significant figures where three significant figures were expected.
- (ii) A good understanding of the processes involved in preparing a solution was shown in this question. In some responses, the solid was added directly to the volumetric flask without previously dissolving it. Others did not specify the use of **distilled** or **de-ionised** water and some added a measured volume of  $250\text{ cm}^3$  to the solid, which would have affected the total volume of the solution. In a few cases, lists of apparatus were given as an answer instead of the required process.
- (iii) This question needed an explanation about the rapid change in colour at the point at which the sodium thiosulfate was used up and the first excess of iodine occurred. Often answers simply repeated information given in the question about the colour change between iodine and starch or just said that the starch was acting as an indicator.
- (b) To complete the table it was necessary to keep the volume of the ammonium persulfate constant and vary the volumes of the potassium iodide, using the water to maintain an overall volume of  $35.0\text{ cm}^3$  because it was the concentration of the potassium iodide that was being altered. The main error in response to this was to vary both the volumes of ammonium persulfate and the volumes of potassium iodide.

- (c) (i) In this calculation the rate of production of iodine was only linked to the rate of disappearance of the sodium thiosulfate. Some candidates linked the number of moles of iodine to all three reactants, sometimes adding the values and in other cases subtracting values. Some candidates divided the number of moles of iodine by 134 to find the rate without first changing moles into concentration. The total volume of the solution was  $21\text{ cm}^3$ , which was missed by some candidates and various suggestions including 5, 15 and  $20\text{ cm}^3$  were given.
- (ii) This was answered well; a few responses gave repeating until the titres were similar rather than time. Some also suggested changing the volumes or concentrations of the solution, which would mean performing new experiments rather than checking the reliability of the existing data.
- (iii) The maximum error for the burette with  $0.1\text{ cm}^3$  graduations is  $0.05\text{ cm}^3$ . Two measurements were needed, initial and final, so the calculation should be:

$$(2 \times 0.05/5) \times 100 = 2.0 \%$$

Some candidates divided by 50 rather than 5; others had maximum errors of  $0.1\text{ cm}^3$  or assumed that only one reading was taken.

- (d) This was answered quite well. Some candidates thought that a small quantity of sodium thiosulfate would behave in the same way as no sodium thiosulfate. Others thought that the starch had been added at the wrong time and a few thought that the apparatus was not clean.
- (e) For this question the chemical referred to needed naming, the specific hazard it presented (as shown in the text) needed to be stated along with the precaution associated with it. This was a case where some candidates gave more than the one answer required. In a few cases they did not name the chemical they were referring to and some candidates did not give the correct precaution for their named hazard.

## Question 2

- (a) The volume of hydrogen needed to be calculated by subtracting the reading on the burette from the initial reading and this then needed to be recorded to two decimal places. The time (given in seconds) needed to be multiplied by 0.80A. The answers for charge passed were done well and in general the same applied to volume of hydrogen gas produced. Sometimes the answers for the volume were only given to one decimal place and in a few cases the volume obtained used the initial reading as  $50\text{ cm}^3$ .
- (b) The plotting of the line and the drawing of the best-fit line were done well. The most frequent error in plotting was omitting the point at 0, 0.00.
- (c) The answer to this required an understanding of the fact that all the points were very close or on the line of best fit.
- (d) (i) Gradients were generally well calculated. It was necessary to choose co-ordinates that covered at least half of an axis, in this case covering 180 coulombs on the x-axis. Some calculations were inverted finding  $x/y$  rather than  $y/x$ .
- (ii) The answer for this required that the previous answer was divided by 24 000 to account for the difference in units. This was often done correctly but errors involved either dividing by 24 alone or multiplying by 24.
- (iii) The answer for this required the reciprocal of twice the answer to (ii). In some cases the reciprocal of (ii) was found and this was multiplied by 2, in other cases the candidates used the value of the Faraday constant in their calculation.
- (e) (i) This required a simple calculation to work out that the volume of oxygen was  $9\text{ cm}^3$ , half the volume of the hydrogen and then sketching this on the graph. This was generally done well.

- (ii) For this the candidates needed to refer to the slight solubility of oxygen in water or sulfuric acid. Some thought that this was an explanation of the sketch graph and referred to ratios, while others suggested that the oxygen would react with the hydrogen ions in the solution to form water.
- (f) (i) A line with a negative gradient was needed here. This was answered well. Incorrect answers included lines with positive gradients and curves.
- (ii) With the decrease in pressure there would be an increase in the volume of the gas, this means that the Faraday constant would decrease in value. While this answer was often seen, the explanation for the decrease in value was not always given. Some suggested, incorrectly, that the number of moles of the gas would increase, which negated any reference to the increase in volume.
- (g) For this question, using the data given in the table, it was expected that the copper anode would dissolve producing copper(II) ions and this would reduce the volume of oxygen produced. Initially, there would be no effect on the volume of hydrogen produced. However, many candidates used the data to construct electrochemical cells, producing equations that were not appropriate for electrolysis and selective discharge. A number of candidates had the wrong gas being produced at the electrodes.



# CHEMISTRY

**Paper 9701/52**  
**Planning, Analysis and Evaluation**

## Key messages

Candidates need to be aware of the need for precision of apparatus for the task, e.g. a measuring cylinder is an unsuitable piece of apparatus to measure  $12.50\text{ cm}^3$  of solution in **Question 1(a)(ii)**; instead a burette is needed.

Candidates need to be aware that rounding in a calculation should be done at the end of the calculation. Early rounding often resulted in incorrect final answers being produced in **Questions 1(a)(vi)** and **1(c)(i)**.

In calculating the percentage of a compound found in an impure sample, candidates need to be aware that this value can never exceed 100% and if their answer indicates a value in excess of 100%, then some checking of their working is needed.

It was noticeable that the standard of graph work of weaker candidates had improved with many of these candidates receiving full credit for **Question 2(b)**.

## General comments

The more practical work that a candidate has carried out during their studies the more prepared and confident they will be in answering the questions on this paper. The paper is intended to utilise candidates' knowledge and application of practical-based procedures so it is important that candidates do the amount of practical work expected for a typical A level syllabus.

## Comments on specific questions

### Question 1

- (a) (i)** Most candidates realised that the presence of a base, i.e.  $\text{Cu}(\text{OH})_2$ , in addition to  $\text{CuCO}_3$ , would rule out titration as a means of determining the percentage of  $\text{CuCO}_3$  present in verdigris as the hydrochloric acid would react with both substances.
- (ii)** For the first marking point, candidates needed to determine the volume of  $10.0\text{ mol dm}^{-3}\text{ HCl}(\text{aq})$  required ( $12.5(0)\text{ cm}^3$ ) and needed to state the apparatus used to measure this volume and to transfer this volume into a suitable piece of apparatus prior to dilution. Many candidates erroneously suggested using a measuring cylinder for this task, which is not sufficiently precise for making up standard solutions. Many of the better responses suggested using (graduated) pipettes. Better performing candidates were able to suggest a burette as being the most appropriate apparatus to deliver  $12.50\text{ cm}^3$  of a solution into a volumetric flask.
- For the second marking point, candidates were required to have transferred the  $10.0\text{ mol dm}^{-3}\text{ HCl}(\text{aq})$  into a  $250\text{ cm}^3$  volumetric flask and top up to the mark with distilled water. Most candidates were awarded this credit.
- (iii)** The most common dependent variable chosen by candidates to measure was the volume of carbon dioxide gas produced; other answers such as mass loss (due to release of carbon dioxide) were acceptable.
- (iv)** Most candidates were able to produce reasonable diagrams of suitable apparatus. In order to gain full credit candidates needed to show a suitable reaction vessel and a suitable method of measuring the dependent variable given in **Question 1(a)(iii)**. For gas collection methods, either a labelled gas syringe or a labelled inverted measuring cylinder in a water trough was expected.

The reaction vessel proved a little more problematical. Good responses used sealed 'halved' conical flasks with the acid in one half and the solid verdigris in the other. Another common method involved suspending a small test-tube containing verdigris above acid in a sealed conical flask.

Other candidates were aware that if acid was added to a sealed system, then air would be displaced into the collection vessel before any carbon dioxide was produced and consequently chose to measure the volume of acid added by adding from a burette. Other methods of adding acid to solid verdigris were accepted as long as it was possible to measure the volume of acid added; such methods included tap-funnels.

- (v) Many candidates did not realise that in order to show how the dependent variable changed during the experiment, time would have to be plotted on the  $x$ -axis and the dependent variable would have to be plotted on the  $y$ -axis. Of those who did choose the correct axes, many of the graphs sketched did not indicate that the rate of gas produced (or mass lost) would decrease as the experiment proceeded and many straight lines, rather than curves, were drawn from the origin before (correctly) plateauing out to indicate that the reaction had finished.
- (vi) Despite 'one' appearing in bold in the question, many opted for repetition as a means of ensuring that the **one** experiment was carried out as accurately as possible.
- (vii) Candidates are advised to show working in calculations and to leave rounding off until the end. The first marking point was for determining the number of moles of copper(II) carbonate present. The answer to  $0.5 \div 123.5$  is 0.0040485829... mol. Candidates should write this as 0.00405 mol, but this is not the figure they should use in the next stage of the calculation. Instead the calculator value should be used. It is common to see the phrase 'left in calculator' written against any intermediate values given in working; this is good practice.
- (b) Most candidates gained credit for identifying the hazard, the substance responsible for the hazard and a suitable method of precaution.

Vague responses such as 'wear gloves because they are irritants' received no credit.

Many candidates had not understood the procedure of the experiment, as many suggested the  $\text{HCl(aq)}$  used was an irritant. At no time were the concentrations of  $\text{HCl(aq)}$  being used within the range deemed 'irritant'.  $10.0 \text{ mol dm}^{-3} \text{ HCl(aq)}$  is corrosive and  $0.500 \text{ mol dm}^{-3} \text{ HCl(aq)}$  is below the concentration at which  $\text{HCl(aq)}$  becomes an irritant.

- (c) (i) This multi-step calculation was performed well by the majority of candidates. The most common error was to leave the answer as 73.95% (4 significant figures) or round it to 74% (2 significant figures) instead of writing the answer to 3 significant figures, as required by the question. A small proportion of candidates did not apply the correct stoichiometric ratio to their calculation and an answer in excess of 100% (221.85% before rounding) was seen. Candidates should be advised that the percentage of a compound making up an impure sample can never exceed 100% and if their answer indicates this, then some checking of their working is needed.

- (ii) The many varied answers seen suggested that candidates were not always familiar with the technique of titration, which is a very commonly performed technique undertaken during typical A level practical work. Many candidates did not focus on the most obvious problems and improvements.

The titres were not concordant, so these should have been repeated until there were two titres within  $0.1(0)\text{cm}^3$  of each other. These do not have to be successive titres and do not have to be  $0.1(0)\text{cm}^3$  apart, as two equal titres would be fine.

The indicator and the solution were both blue, so the end-point might not be visible, meaning a different indicator should be used.

Common incorrect responses involved trivial statements such as lack of parallax, human error, random errors or not starting each titration from  $0.0(0)\text{cm}^3$ .

## Question 2

- (a) (i) Most candidates were awarded full credit for completing the table correctly. There were very few arithmetical errors but  $\log[X]$  given to 3 decimal places was seen relatively often.

- (ii) This was answered well and the vast majority of candidates knew that increasing the mass of charcoal would lead to an increase in adsorption. Some suggested this was due to an increase in the number of 'particles' (i.e. atoms or molecules). Most knew the increase in adsorption was related to an increase in surface area.

- (b) The graph was generally drawn well. Most scripts had the points plotted correctly. The judgement shown by the majority of candidates in drawing the line of best fit was sound with most lines (correctly) having a roughly equal number of points on each side, ignoring the anomalous point. One common error in drawing a line of best fit was simply to connect the two extreme points at the top and bottom of the graph. This resulted in nearly all points being on one side of the line.

- (c) Only a minority of candidates did not spot the anomalous point; a larger proportion of candidates were unable to realise that the anomaly suggested that the degree of adsorption was too low. Hence they did not relate the lack of adsorption to possible causes, such as not allowing sufficient time for adsorption to take place or the amount of charcoal being lower than expected amongst other possible, plausible causes.

- (d) (i) Candidates were required to select two points on the line of best fit, which are at least half the graph apart. Candidates should avoid selecting plotted points. The co-ordinates of the points need to be written in  $(x, y)$  format and  $\Delta y / \Delta x$  needs to be calculated to obtain a value for the gradient.

The vast majority of the candidates realised that the gradient was also  $b$  so their answer should be duplicated.

- (ii) It was expected that to determine  $A$ , candidates would simply read the  $y$ -intercept from their graph. Instead, many chose to calculate this using points from the line of best fit and the value  $b$  determined in (d)(i) and substituting into  $y = mx + c$ ; either method was acceptable.

# CHEMISTRY

---

<p><b>Paper 9701/53</b> <b>Planning, Analysis and Evaluation</b></p>
--

## General comments

Even though this is an alternative to practical paper the more chemistry practical that has been performed or seen aids success in an examination of this nature. Familiarity with chemical apparatus gives an appreciation of suitable types and sizes to be used for given procedures.

The introduction to each question often gives relevant information, which should be used as an aid to answering the questions.

Setting out calculations in a clear, logical order is encouraged, along with suitable labelling.

Often calculators produce values as vulgar fractions, which are acceptable only during the course of a calculation but not as a final answer, which needs to be in decimal or standard form to the required significant figures or decimal places. Early or over rounding should be avoided during the course of a calculation; final answers should be correctly rounded and not truncated.

Mass values should be quoted to the same number of decimal places as the data from which they are derived (usually two) and with a mass unit. Similarly, completing data in tables should be continued to the same number of decimal places as any initial data in that table.

Some candidates tend to over answer, providing multiple responses to a question that only requires one answer. This can result in contradictions, which negate correct answers. Candidates should be encouraged to directly respond to each individual question in a straightforward way.

## Comments on specific questions

### Question 1

- (a) (i) Most candidates answered this correctly. Common errors were to calculate the number of moles or the  $M_r$  incorrectly. There was also some incorrect rounding or answers recorded to only two significant figures where three significant figures were expected.
- (ii) A good understanding of the processes involved in preparing a solution was shown in this question. In some responses, the solid was added directly to the volumetric flask without previously dissolving it. Others did not specify the use of **distilled** or **de-ionised** water and some added a measured volume of  $250\text{ cm}^3$  to the solid, which would have affected the total volume of the solution. In a few cases, lists of apparatus were given as an answer instead of the required process.
- (iii) This question needed an explanation about the rapid change in colour at the point at which the sodium thiosulfate was used up and the first excess of iodine occurred. Often answers simply repeated information given in the question about the colour change between iodine and starch or just said that the starch was acting as an indicator.
- (b) To complete the table it was necessary to keep the volume of the ammonium persulfate constant and vary the volumes of the potassium iodide, using the water to maintain an overall volume of  $35.0\text{ cm}^3$  because it was the concentration of the potassium iodide that was being altered. The main error in response to this was to vary both the volumes of ammonium persulfate and the volumes of potassium iodide.

- (c) (i) In this calculation the rate of production of iodine was only linked to the rate of disappearance of the sodium thiosulfate. Some candidates linked the number of moles of iodine to all three reactants, sometimes adding the values and in other cases subtracting values. Some candidates divided the number of moles of iodine by 134 to find the rate without first changing moles into concentration. The total volume of the solution was  $21\text{ cm}^3$ , which was missed by some candidates and various suggestions including 5, 15 and  $20\text{ cm}^3$  were given.
- (ii) This was answered well; a few responses gave repeating until the titres were similar rather than time. Some also suggested changing the volumes or concentrations of the solution, which would mean performing new experiments rather than checking the reliability of the existing data.
- (iii) The maximum error for the burette with  $0.1\text{ cm}^3$  graduations is  $0.05\text{ cm}^3$ . Two measurements were needed, initial and final, so the calculation should be:

$$(2 \times 0.05/5) \times 100 = 2.0 \%$$

Some candidates divided by 50 rather than 5; others had maximum errors of  $0.1\text{ cm}^3$  or assumed that only one reading was taken.

- (d) This was answered quite well. Some candidates thought that a small quantity of sodium thiosulfate would behave in the same way as no sodium thiosulfate. Others thought that the starch had been added at the wrong time and a few thought that the apparatus was not clean.
- (e) For this question the chemical referred to needed naming, the specific hazard it presented (as shown in the text) needed to be stated along with the precaution associated with it. This was a case where some candidates gave more than the one answer required. In a few cases they did not name the chemical they were referring to and some candidates did not give the correct precaution for their named hazard.

## Question 2

- (a) The volume of hydrogen needed to be calculated by subtracting the reading on the burette from the initial reading and this then needed to be recorded to two decimal places. The time (given in seconds) needed to be multiplied by 0.80A. The answers for charge passed were done well and in general the same applied to volume of hydrogen gas produced. Sometimes the answers for the volume were only given to one decimal place and in a few cases the volume obtained used the initial reading as  $50\text{ cm}^3$ .
- (b) The plotting of the line and the drawing of the best-fit line were done well. The most frequent error in plotting was omitting the point at 0, 0.00.
- (c) The answer to this required an understanding of the fact that all the points were very close or on the line of best fit.
- (d) (i) Gradients were generally well calculated. It was necessary to choose co-ordinates that covered at least half of an axis, in this case covering 180 coulombs on the x-axis. Some calculations were inverted finding  $x/y$  rather than  $y/x$ .
- (ii) The answer for this required that the previous answer was divided by 24 000 to account for the difference in units. This was often done correctly but errors involved either dividing by 24 alone or multiplying by 24.
- (iii) The answer for this required the reciprocal of twice the answer to (ii). In some cases the reciprocal of (ii) was found and this was multiplied by 2, in other cases the candidates used the value of the Faraday constant in their calculation.
- (e) (i) This required a simple calculation to work out that the volume of oxygen was  $9\text{ cm}^3$ , half the volume of the hydrogen and then sketching this on the graph. This was generally done well.

- (ii) For this the candidates needed to refer to the slight solubility of oxygen in water or sulfuric acid. Some thought that this was an explanation of the sketch graph and referred to ratios, while others suggested that the oxygen would react with the hydrogen ions in the solution to form water.
- (f) (i) A line with a negative gradient was needed here. This was answered well. Incorrect answers included lines with positive gradients and curves.
- (ii) With the decrease in pressure there would be an increase in the volume of the gas, this means that the Faraday constant would decrease in value. While this answer was often seen, the explanation for the decrease in value was not always given. Some suggested, incorrectly, that the number of moles of the gas would increase, which negated any reference to the increase in volume.
- (g) For this question, using the data given in the table, it was expected that the copper anode would dissolve producing copper(II) ions and this would reduce the volume of oxygen produced. Initially, there would be no effect on the volume of hydrogen produced. However, many candidates used the data to construct electrochemical cells, producing equations that were not appropriate for electrolysis and selective discharge. A number of candidates had the wrong gas being produced at the electrodes.