



# Cambridge IGCSE™

CANDIDATE  
NAME

CENTRE  
NUMBER

--	--	--	--	--

CANDIDATE  
NUMBER

--	--	--	--



**CO-ORDINATED SCIENCES**

**0654/42**

Paper 4 Theory (Extended)

**October/November 2023**

**2 hours**

You must answer on the question paper.

No additional materials are needed.

## INSTRUCTIONS

- Answer **all** questions.
- Use a black or dark blue pen. You may use an HB pencil for any diagrams or graphs.
- Write your name, centre number and candidate number in the boxes at the top of the page.
- Write your answer to each question in the space provided.
- Do **not** use an erasable pen or correction fluid.
- Do **not** write on any bar codes.
- You may use a calculator.
- You should show all your working and use appropriate units.

## INFORMATION

- The total mark for this paper is 120.
- The number of marks for each question or part question is shown in brackets [ ].
- The Periodic Table is printed in the question paper.

This document has **32** pages. Any blank pages are indicated.

1 (a) Fig. 1.1 is a diagram of the female reproductive system in humans.

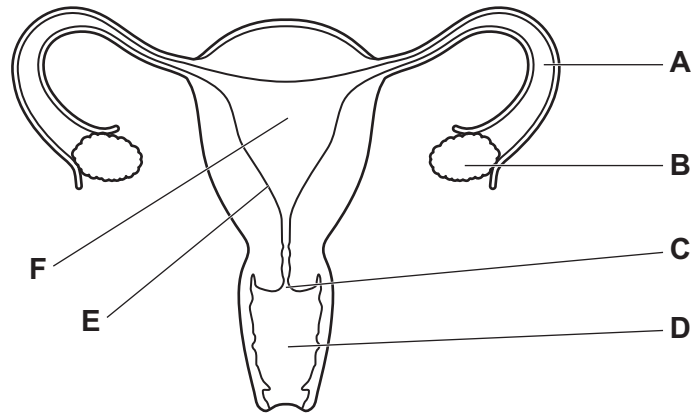

Fig. 1.1

Identify the letter from Fig. 1.1 that represents the part where:

- eggs are released .....
- fertilisation occurs .....
- implantation occurs .....
- meiosis occurs .....

[4]

(b) A zygote divides to form an embryo.

Describe this type of cell division.

.....

.....

.....

..... [3]

(c) During pregnancy the growing baby is supported by the placenta, umbilical cord, amniotic fluid and amniotic sac.

(i) State the function of the amniotic fluid.

.....

..... [1]

(ii) Describe the function of the placenta and the umbilical cord.

.....

.....

.....

.....

..... [3]

[Total: 11]

2 The element carbon exists as 3 naturally occurring isotopes.

Fig. 2.1 shows an atom of **one** isotope, carbon-14.

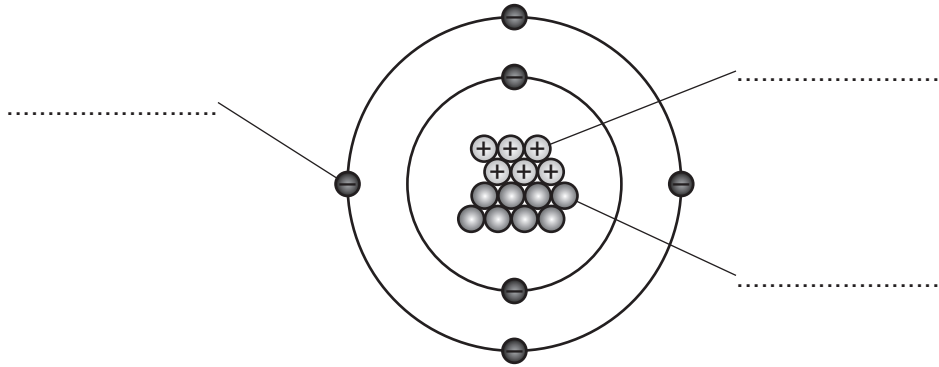
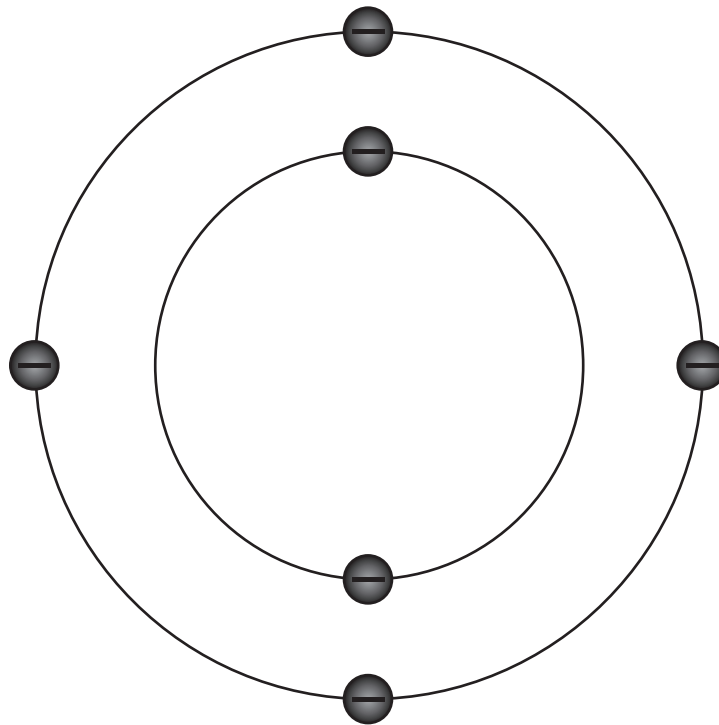

**Fig. 2.1**

(a) (i) Complete the labels on Fig. 2.1.

[3]

(ii) Fig. 2.2 shows an atom of a different isotope of carbon.



**Fig. 2.2**

Complete Fig. 2.2 to show the particles in the nucleus of one of the **other two** isotopes of carbon. [2]

(iii) The different isotopes of carbon all have the same chemical properties.

Explain why.

.....  
 ..... [1]

(b) Carbon reacts with oxygen to form carbon dioxide.

State the test for carbon dioxide and its positive result.

test .....

positive result ..... [2]

(c) Compounds that only contain carbon and hydrogen can form compounds with only single covalent bonds.

Complete the sentence about these compounds.

Choose words from the list.

**addition**      **alkenes**      **hydrocarbons**  
**polymers**      **saturated**      **unsaturated**

Carbon and hydrogen compounds with only single covalent bonds

are called ..... [2]

[Total: 10]

3 Fig. 3.1 shows a circuit used by students investigating how the resistance of a metal wire varies with length.

(a) The students use an ammeter and a voltmeter to measure the current in and potential difference across the wire.

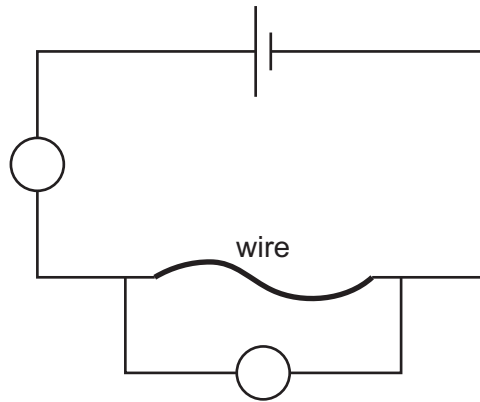

**Fig. 3.1**

(i) Complete Fig. 3.1 to show the correct symbols and positions for the ammeter and the voltmeter. [1]

(ii) When the wire is 20 cm long, the ammeter reads 0.80 A and the voltmeter reads 3.0 V.

Calculate the resistance of the wire. State the correct unit for your answer.

resistance = ..... unit ..... [3]

(iii) On Fig. 3.2 sketch a graph to show how the resistance of the wire varies with length. [2]

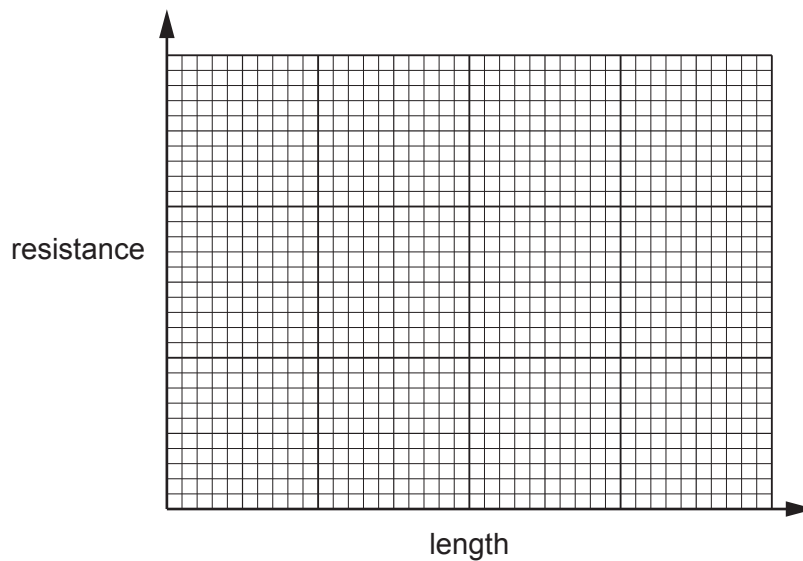

**Fig. 3.2**

(b) The student notices that when the circuit is left switched on, the wire becomes warm.

Describe how conduction transfers thermal energy in the metal wire.

.....  
.....  
.....  
..... [3]

[Total: 9]

- 4 (a) A student investigates the effect of humidity on the rate of water uptake in plant shoots.

Fig. 4.1 shows the apparatus they use.

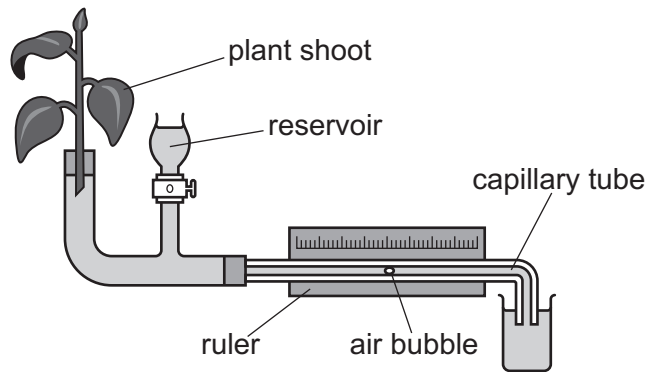

**Fig. 4.1**

The student measures the distance moved by the air bubble in 2 minutes.

The student then covers the plant shoot with a plastic bag to increase the humidity and repeats the investigation.

The results are used to calculate the rate of movement of the air bubble.

Table 4.1 shows their results.

**Table 4.1**

plant shoot conditions	distance moved by the air bubble in 2 minutes / mm	rate of movement of the air bubble / mm per minute
low humidity	21.0	
high humidity	5.0	2.5

- (i) Calculate the rate of movement of the air bubble at low humidity and complete Table 4.1. [1]

- (ii) The rate of water uptake is approximately equivalent to the rate of transpiration.

Complete the sentences to describe and explain the results in Table 4.1.

When the humidity is increased the distance moved by the air bubble in 2 minutes decreased by ..... mm.

Higher humidity means the concentration of water vapour in the air around the leaf increases.

This decreases the concentration ..... between the inside and the outside of the leaf.



Less water is lost from the surfaces of the mesophyll cells by the process of .....

Less water vapour diffuses through the ..... [4]

(iii) Suggest why **not all** the water taken up by the roots of the plant is lost to the atmosphere.  
.....  
..... [1]

(iv) State **one other** factor that affects the rate of transpiration.  
..... [1]

(b) Xylem vessels can draw up a column of water through transpiration pull.

(i) Describe how transpiration pull causes the movement of water molecules.  
.....  
..... [1]

(ii) State the term used to describe how the water molecules are held together in the column of water.  
..... [1]

(iii) State **one other** substance transported in the xylem.  
..... [1]

[Total: 10]

- 5 Table 5.1 gives some information about the properties of the Group VII elements.

**Table 5.1**

element	boiling point/°C	state at room temperature
fluorine	-188	gas
chlorine		gas
bromine	59	
iodine	184	solid

- (a) (i) Predict the boiling point of chlorine.

Write your answer in Table 5.1.

[1]

- (ii) Predict the state at room temperature of bromine.

Write your answer in Table 5.1.

[1]

- (b) Bromine has a lower boiling point than iodine.

Tick (✓) **one** box to show the correct explanation.

Bromine is a covalent compound and iodine is an ionic compound.

Bromine is more reactive than iodine.

The covalent bonds between bromine atoms are weaker.

The forces between bromine molecules are weaker.

[1]

- (c) Chlorine,  $Cl_2$ , reacts with sodium bromide, NaBr.

Sodium chloride, NaCl, and bromine are made.

- (i) Construct the balanced symbol equation for this reaction.

..... [2]

(ii) Sodium chloride is an ionic compound.

A sodium atom has an electronic structure of 2.8.1.

A chlorine atom has an electronic structure of 2.8.7.

Draw a dot-and-cross diagram to show the ions formed when sodium bonds with chlorine.

Include the charges on the ions.

[3]

(iii) Concentrated aqueous sodium chloride conducts electricity.

Tick (✓) **one** box to show the correct explanation.

Concentrated aqueous sodium chloride contains electrons which can move.

Concentrated aqueous sodium chloride contains ions which can move.

Concentrated aqueous sodium chloride contains the metal sodium.

Concentrated aqueous sodium chloride contains water.

[1]

(iv) State the name of the product at the **anode** in the electrolysis of concentrated aqueous sodium chloride.

..... [1]

[Total: 10]

6 Light is a transverse wave which is refracted by a transparent material.

(a) Fig. 6.1 shows the refraction of a ray of light as it enters a transparent block.

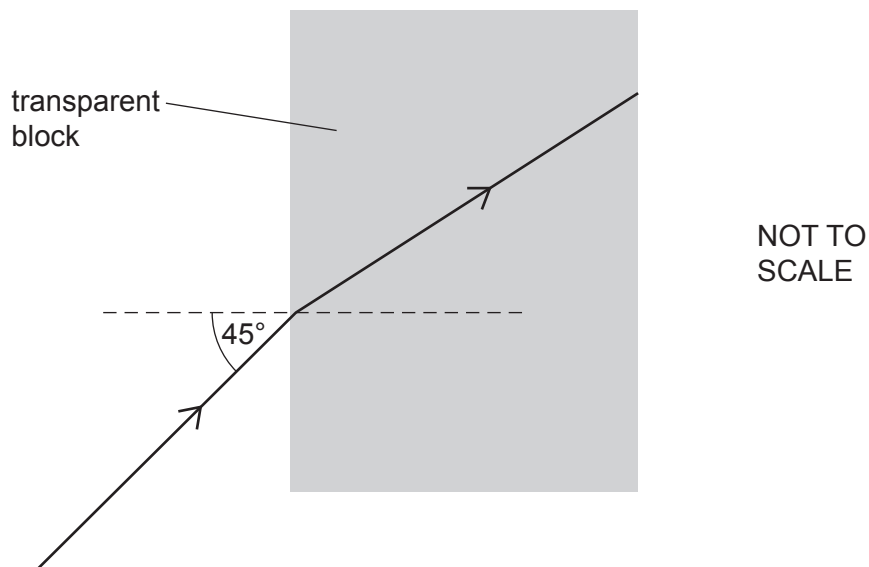

Fig. 6.1

(i) The refractive index of the transparent block is 1.55.

The angle of incidence is  $45^\circ$ . Calculate the angle of refraction.

angle of refraction = ..... $^\circ$  [2]

(ii) Information can be transmitted using the total internal reflection of light in an optical fibre.

Fig. 6.2 shows a ray of light entering an optical fibre.



Fig. 6.2

On Fig. 6.2 complete the ray diagram to show how an optical fibre can transmit light along the fibre. [2]

(iii) State what is meant by the term critical angle.

.....  
..... [1]

(b) Lasers are used to produce light of one single wavelength.

A battery powered laser has a power output of 0.0060 W and an efficiency of 40%.

(i) Calculate the power input provided by the laser's batteries.

power input = .....W [2]

(ii) A battery of three 1.5 V cells in a laser provides 20.0 C of charge before the cells need replacing.

Calculate how long this battery will power the laser for.

time = ..... s [3]

[Total: 10]

7 (a) Fig. 7.1 is a diagram of a villus.

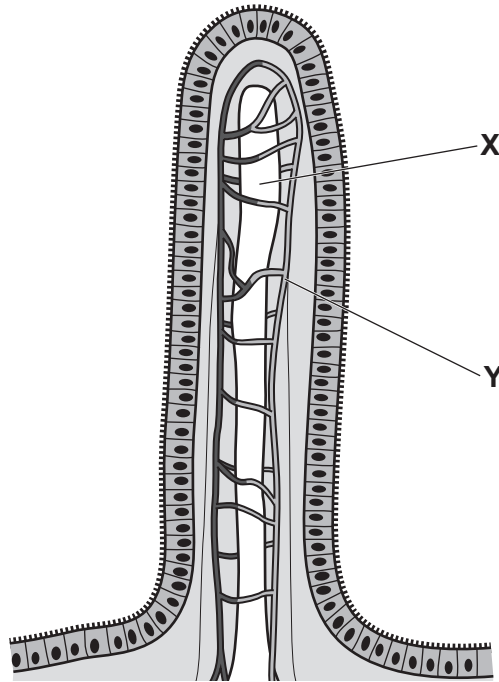

Fig. 7.1

(i) State the name of the part labelled Y in Fig. 7.1.

..... [1]

(ii) Describe the function of the part labelled X in Fig. 7.1.

.....  
..... [1]

(iii) State where villi are found in the alimentary canal.

..... [1]

(b) Coeliac disease is a condition which causes the villi to become inflamed and flattened.

Explain why coeliac disease may cause weight loss.

.....  
.....  
.....  
..... [2]

(c) Table 7.1 shows some digestive enzymes, their substrates and product(s).

Complete Table 7.1.

**Table 7.1**

enzyme	substrate	product(s)
.....	.....	simpler sugars
protease	.....	.....

[2]

(d) State **two** parts of the alimentary canal where protease is secreted.

1 .....

2 .....

[2]

[Total: 9]

- 8 A student investigates the reaction between **large** marble chips and excess dilute hydrochloric acid.

Fig. 8.1 shows the apparatus they use.

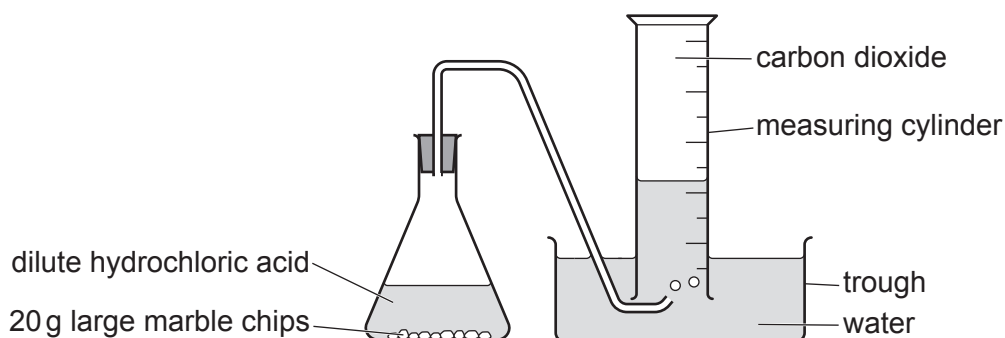

Fig. 8.1

The student measures the total volume of carbon dioxide gas every 30 seconds.

Fig. 8.2 shows a graph of the student's results.

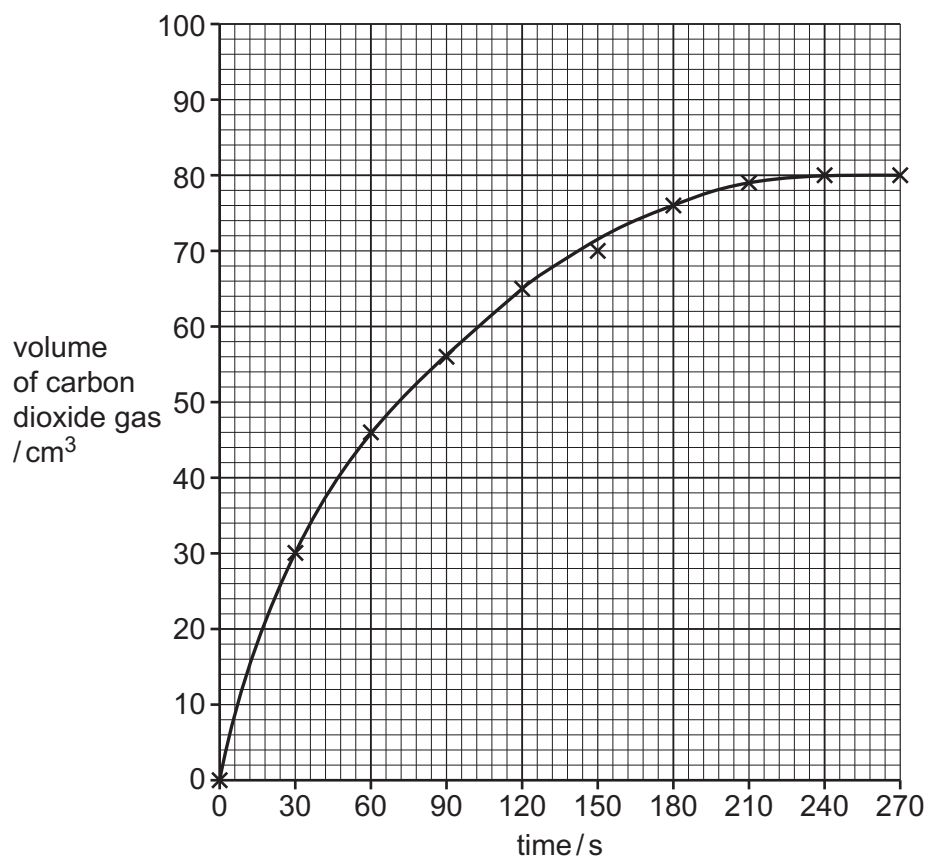

Fig. 8.2

- (a) (i) State the time at which the reaction stops.

time = ..... s [1]



- (ii) The student repeats the experiment using 20 g of **small** marble chips, instead of 20 g of large marble chips.

Sketch a line on Fig. 8.2 to show the results you would expect. [2]

- (b) The student repeats the experiment again.

This time the student uses:

- the same mass of small marble chips
- the same volume of hydrochloric acid
- **more concentrated** hydrochloric acid.

Explain, using ideas about collisions between particles, why the reaction is faster.

.....  
 .....  
 ..... [3]

- (c) The reaction between marble chips and dilute hydrochloric acid is an example of an **exothermic** reaction.

Use the axes shown in Fig. 8.3 to draw and label the energy level diagram for this type of reaction.

Label:

- the energy levels of the reactants and the products
- the energy change in the reaction
- the activation energy of the reaction.

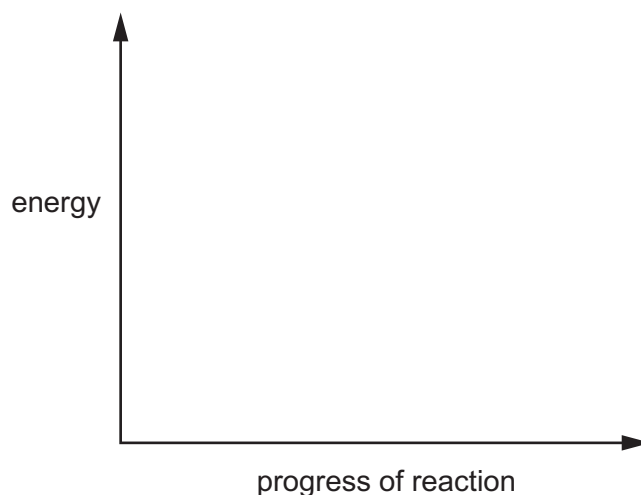

**Fig. 8.3**

[3]

- (d) When 5 g of marble chips,  $\text{CaCO}_3$ , react with dilute hydrochloric acid,  $\text{HCl}$ , 2.2 g of carbon dioxide is produced.



Calculate the volume occupied by this 2.2 g of carbon dioxide gas.

The molar gas volume at room temperature and pressure is  $24 \text{ dm}^3$ .

[ $A_r$ : C, 12; O, 16]

volume of carbon dioxide gas = .....  $\text{dm}^3$  [3]

[Total: 12]

**BLANK PAGE**

9 Fig. 9.1 shows a simple d.c. motor with a coil of wire containing 100 turns.

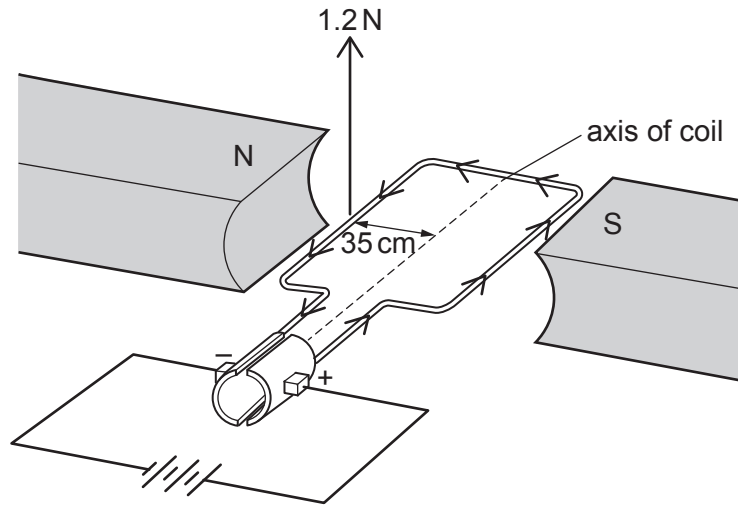

Fig. 9.1

- (a) The current in the coil causes forces to act on the coil, which make it turn about its axis.
- (i) Fig. 9.1 shows a force of 1.2 N acting at 90° to the coil, at a distance of 3.5 cm from the axis.

Calculate the moment of the force on the coil.

moment = ..... Nm [3]

- (ii) Suggest how the magnitude of the force in (a)(i) changes when both the number of turns on the coil is doubled and the current is doubled.

.....

..... [2]

- (b) Fig. 9.2 shows a toy boat. The toy boat uses a motor similar to that shown in Fig. 9.1 to propel the toy boat across a pond.

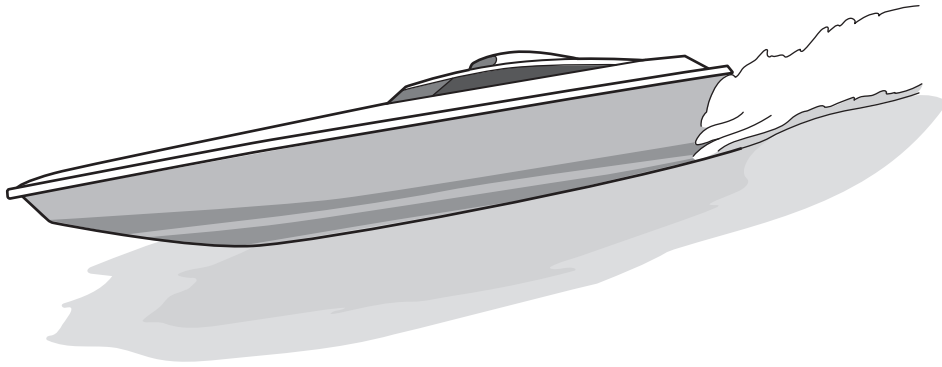

**Fig. 9.2**

The toy boat has a mass of 0.60 kg and travels at a maximum speed of 3.0 m/s.

Calculate the maximum kinetic energy of the toy boat.

State the unit for your answer.

kinetic energy = ..... unit ..... [3]

(c) Fig. 9.3 shows a speed-time graph for part of the toy boat's journey.

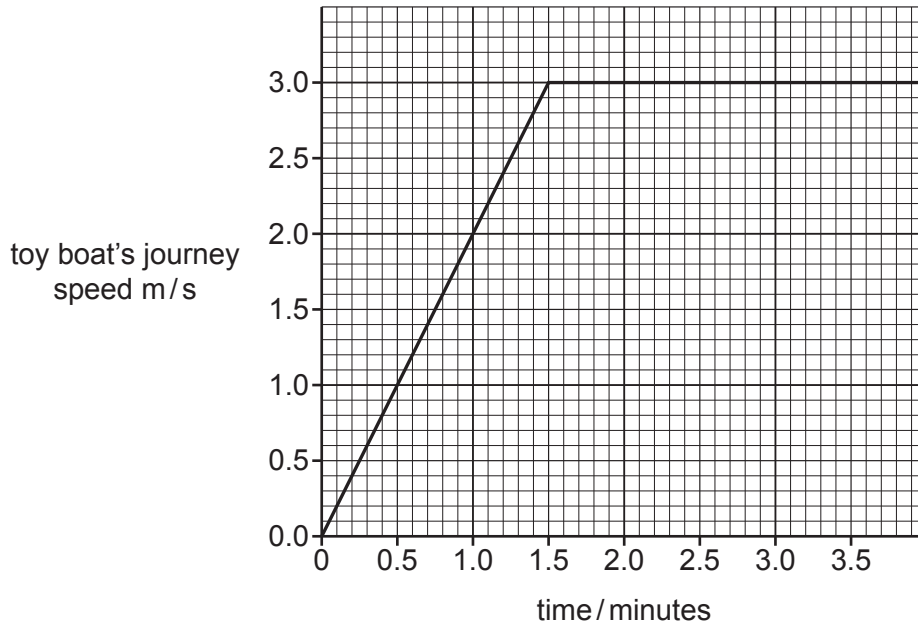

**Fig. 9.3**

(i) Use Fig. 9.3 to describe the motion of the toy boat for this part of the journey.

.....

.....

..... [2]

(ii) Suggest why the shape of this graph is **not** a realistic description of the motion of the toy boat at 1.5 minutes.

.....

.....

..... [1]

[Total: 11]

10 (a) Table 10.1 shows the effect of adrenaline on blood glucose concentration.

**Table 10.1**

blood glucose concentration	
before adrenaline injection in g/dm <sup>3</sup>	after adrenaline injection in g/dm <sup>3</sup>
800	1200

(i) Calculate the percentage increase in blood glucose concentration after an injection of adrenaline.

..... % [2]

(ii) Suggest the target organ of adrenaline that causes the change shown in Table 10.1.

..... [1]

(iii) Change in blood glucose concentration is **one** effect of adrenaline.

State **two other** effects of adrenaline on the body.

1 .....

2 .....

[2]

(iv) State the name of the component of blood that transports adrenaline.

..... [1]

(b) Chemicals also control activities in plants.

(i) State **one** example of chemical control of plant growth in response to a stimulus.

..... [1]

(ii) State the name of the chemical that controls growth in plant shoots.

..... [1]

(iii) Complete the definition of the term growth.

Growth is a permanent increase in size and .....

by an increase in .....

[2]

[Total: 10]

- 11 A scientist investigates food colourings using paper chromatography.

Fig. 11.1 shows the chromatogram produced.

The result for dye **A** is **not** shown.

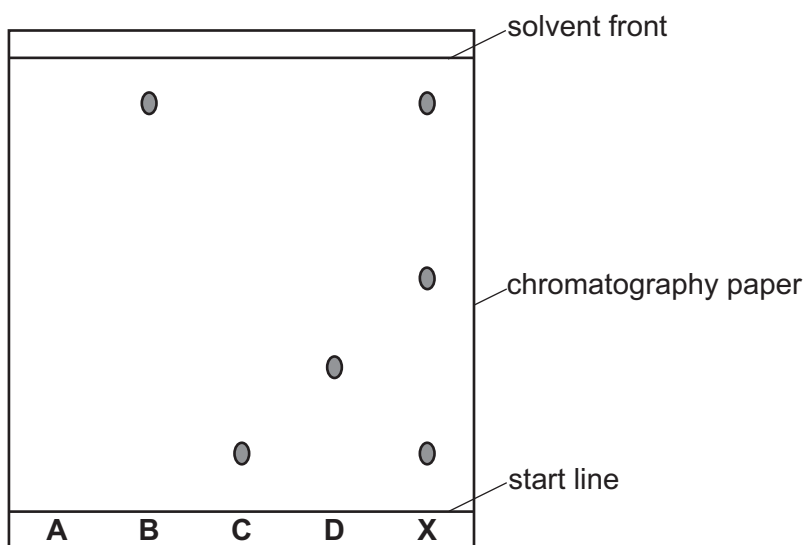

Fig. 11.1

- (a) Identify which dyes, **B**, **C** or **D**, are in the food colouring **X**.

..... [1]

- (b) The  $R_f$  value of a food colouring is calculated using the formula

$$R_f = \frac{\text{distance travelled by substance}}{\text{distance travelled by solvent}}$$

Calculate the  $R_f$  value for dye **B**.

Show your working.

$R_f$  value = ..... [2]



(c) Food colouring **A** has an  $R_f$  value of 0.44.

Calculate the distance travelled by food colouring **A**.

distance travelled = ..... cm [2]

(d) The scientist makes a solution of food colouring **B**.

They dissolve 2.43 g of the food colouring in  $200 \text{ cm}^3$  of distilled water.

Calculate the concentration of the solution made in  $\text{mol/dm}^3$ .

The relative molecular mass,  $M_r$ , of the food colouring is 486.

concentration = .....  $\text{mol/dm}^3$  [3]

[Total: 8]

12 Radon is a radioactive gas which occurs naturally in rocks and soil.

(a) Radon-222 ( $^{222}_{86}\text{Ra}$ ) is an unstable isotope which decays by emitting an alpha particle.

(i) Use the correct nuclide notation to show the decay of radon-222.



[2]

(ii) Draw lines to match an alpha particle with its correct characteristics. One line has been drawn as an example.

alpha particle	has a charge of 0
	has a charge of -1
	has a charge of +2
	has a mass of 0
	has a mass of 2
	has a mass of 4
	has a low ionizing ability
	has a high ionizing ability
	can penetrate paper
	can penetrate aluminium
	can penetrate lead

[1]

- (iii) Complete Fig. 12.1 to show the path of an alpha particle as it travels through the electric field between two charged plates. [1]

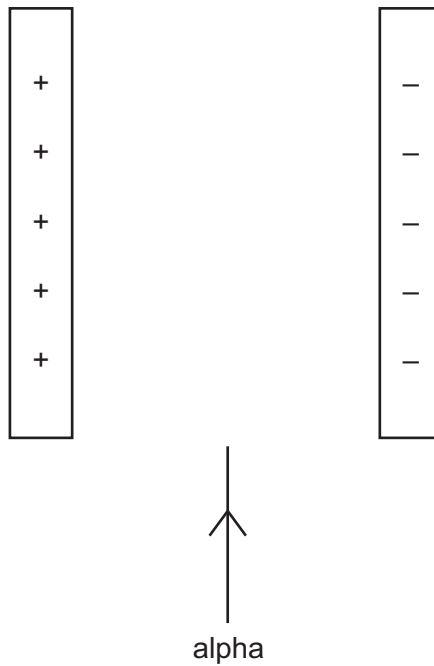

Fig. 12.1

- (b) A sample of radon gas is stored in a container with a fixed volume.
- (i) Explain, in terms of the molecular motion, why the pressure in the radon gas increases when the temperature is increased.

.....

.....

.....

.....

..... [3]

(ii) The volume of the container is  $0.050 \text{ m}^3$ .

The density of the radon gas is  $9.7 \text{ kg/m}^3$ .

Calculate the weight of the radon gas in the container.

The gravitational field strength,  $g$ , is  $10 \text{ N/kg}$ .

weight = ..... N [3]

[Total: 10]





**BLANK PAGE**

---

Permission to reproduce items where third-party owned material protected by copyright is included has been sought and cleared where possible. Every reasonable effort has been made by the publisher (UCLES) to trace copyright holders, but if any items requiring clearance have unwittingly been included, the publisher will be pleased to make amends at the earliest possible opportunity.

To avoid the issue of disclosure of answer-related information to candidates, all copyright acknowledgements are reproduced online in the Cambridge Assessment International Education Copyright Acknowledgements Booklet. This is produced for each series of examinations and is freely available to download at [www.cambridgeinternational.org](http://www.cambridgeinternational.org) after the live examination series.

Cambridge Assessment International Education is part of Cambridge Assessment. Cambridge Assessment is the brand name of the University of Cambridge Local Examinations Syndicate (UCLES), which is a department of the University of Cambridge.

