



# Cambridge IGCSE™

**CO-ORDINATED SCIENCES**

**0654/13**

Paper 1 Multiple Choice (Core)

**May/June 2020**

**45 minutes**

You must answer on the multiple choice answer sheet.

You will need: Multiple choice answer sheet  
Soft clean eraser  
Soft pencil (type B or HB is recommended)

## INSTRUCTIONS

- There are **forty** questions on this paper. Answer **all** questions.
- For each question there are four possible answers **A, B, C** and **D**. Choose the **one** you consider correct and record your choice in soft pencil on the multiple choice answer sheet.
- Follow the instructions on the multiple choice answer sheet.
- Write in soft pencil.
- Write your name, centre number and candidate number on the multiple choice answer sheet in the spaces provided unless this has been done for you.
- Do **not** use correction fluid.
- Do **not** write on any bar codes.
- You may use a calculator.

## INFORMATION

- The total mark for this paper is 40.
- Each correct answer will score one mark. A mark will not be deducted for a wrong answer.
- Any rough working should be done on this question paper.
- The Periodic Table is printed in the question paper.

This document has **16** pages. Blank pages are indicated.



- 1 The diagram shows some apparatus that can be used to test for one of the characteristics of life.

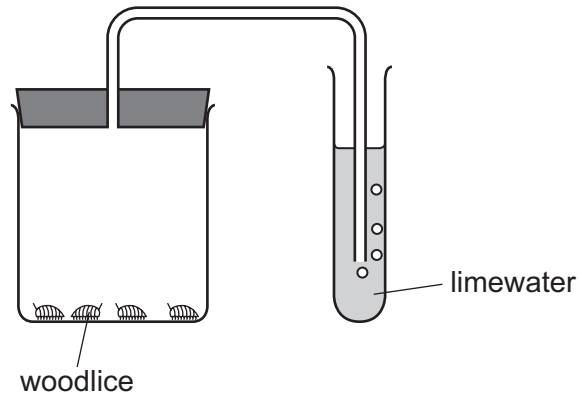

Which characteristic is being tested?

- A excretion
  - B nutrition
  - C reproduction
  - D sensitivity
- 2 The diagram shows molecules of a gas at different concentrations either side of a permeable membrane.

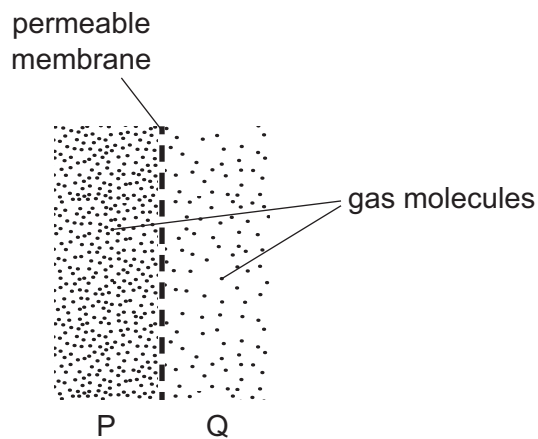

In which direction will the molecules move?

- A both ways, but more from P to Q
- B both ways, but more from Q to P
- C from P to Q only
- D from Q to P only

- 3 A food contains reducing sugar, but no starch.

What colours will be obtained if samples of the food are tested with Benedict's solution and with iodine solution?

	Benedict's test	iodine test
<b>A</b>	blue	blue-black
<b>B</b>	blue	brown
<b>C</b>	red-orange	blue-black
<b>D</b>	red-orange	brown

- 4 Which type of molecule is an enzyme?

- A** carbohydrate
- B** fat
- C** protein
- D** vitamin

- 5 An investigation was carried out to show that carbon dioxide was necessary for photosynthesis to occur in a plant.

Which conditions should the plant be kept in as a suitable control for this experiment?

- A** clear container, with lots of carbon dioxide
- B** clear container, without any carbon dioxide
- C** black container, with lots of carbon dioxide
- D** black container, without any carbon dioxide

- 6 Why is calcium needed in the diet?

- A** to make carbohydrates
- B** to make teeth
- C** to make enzymes
- D** to make protein

7 An oxygenated red blood cell returns to the heart from the lungs.

Which sequence describes the route the red blood cell follows as it delivers its oxygen to a kidney?

- A left ventricle → aorta → renal artery
- B left ventricle → aorta → renal vein
- C right ventricle → aorta → renal artery
- D right ventricle → aorta → renal vein

8 Which processes use energy released by respiration?

- 1 cell division
- 2 diffusion
- 3 osmosis
- 4 muscle contraction
- 5 protein synthesis

- A 1, 2 and 3
- B 1, 3 and 4
- C 1, 4 and 5
- D 4 and 5 only

9 What is the definition of homeostasis?

- A controlling body temperature
- B controlling responses to stimuli
- C maintaining a constant external environment
- D maintaining a constant internal environment

10 The diagram shows a section through a pea flower.

Where does fertilisation occur?

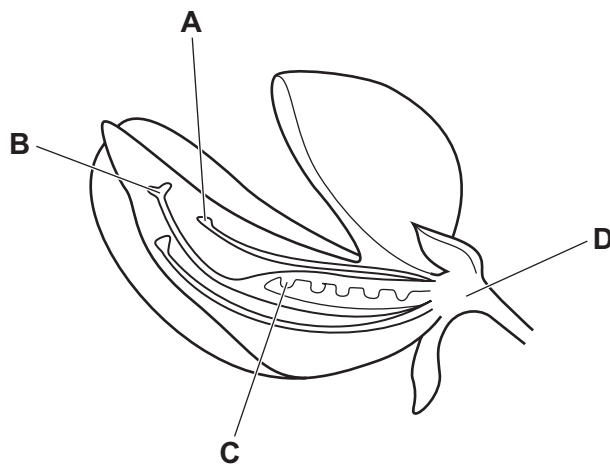

11 In cats, the allele for short hair is dominant to the allele for long hair. Two long haired cats are bred together.

What hair length will the offspring have?

- A all long haired
- B all mid length hair
- C all short haired
- D 50% long and 50% short haired

12 Where does the principle source of energy for an ecosystem come from?

- A decay
- B the soil
- C the Sun
- D water

13 What could deforestation cause?

- A a decrease in carbon dioxide levels and a decrease in flooding
- B a decrease in carbon dioxide levels and an increase in flooding
- C an increase in carbon dioxide levels and a decrease in flooding
- D an increase in carbon dioxide levels and an increase in flooding

14 Which statement about atoms and molecules is correct?

- A All molecules are gases at room temperature and pressure.
- B An atom is the smallest part of an element.
- C Atoms of the same element all have the same mass.
- D Molecules always contain atoms of more than one element.

15 One isotope of oxygen is  $^{16}_8\text{O}$ .

Which diagram represents a different isotope of oxygen?

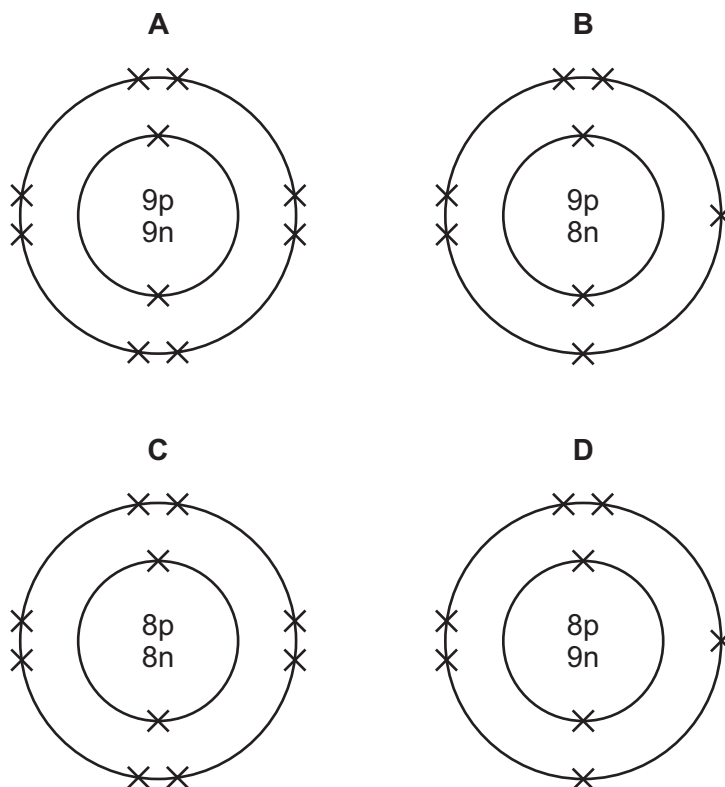

16 What happens to a tellurium atom when it forms a tellurium ion,  $\text{Te}^{2-}$ ?

- A It gains two electrons.
- B It gains two protons.
- C It loses two electrons.
- D It loses two protons.

17 The diagram shows the electrolysis of lead(II) bromide using inert electrodes.

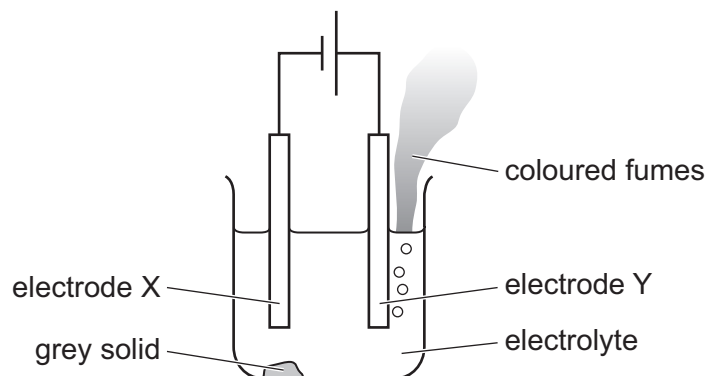

Which statement about this experiment is correct?

- A Electrode X is positively charged.
  - B The coloured fumes are produced at the negative electrode.
  - C The electrolyte is lead(II) bromide.
  - D The grey solid is lead(II) bromide.
- 18 Which reaction involves both oxidation and reduction?
- A calcium carbonate  $\rightarrow$  calcium oxide + carbon dioxide
  - B copper oxide + carbon  $\rightarrow$  copper + carbon dioxide
  - C silver nitrate + potassium chloride  $\rightarrow$  silver chloride + potassium nitrate
  - D sulfuric acid + sodium hydroxide  $\rightarrow$  sodium sulfate + water
- 19 What test is used to test for chlorine?
- A damp litmus paper
  - B glowing splint
  - C lighted splint
  - D limewater
- 20 Which row describes properties of Group I elements?

	electrical conductivity	reaction with water
<b>A</b>	conductor	does not react
<b>B</b>	insulator	reacts
<b>C</b>	conductor	reacts
<b>D</b>	insulator	does not react

21 Which statement is **not** a reason why aluminium is used in aircraft manufacture?

- A It forms low density alloys.
- B It is malleable.
- C It is more reactive than iron.
- D It is resistant to corrosion.

22 A colourless liquid is added to blue cobalt chloride paper. The paper turns pink.

What does this show about the liquid?

- A It contains water.
- B It is acidic.
- C It is neutral.
- D It is pure water.

23 Which three elements are contained in fertilisers to increase crop yield?

- A calcium, nitrogen, phosphorus
- B calcium, nitrogen, potassium
- C calcium, phosphorus, potassium
- D nitrogen, phosphorus, potassium

24 When limestone is heated it thermally decomposes into lime.

What is the word equation for this reaction?

- A calcium carbonate → calcium + carbon dioxide
- B calcium carbonate → calcium oxide + carbon dioxide
- C calcium hydrogencarbonate → calcium + carbon dioxide + water
- D calcium hydrogencarbonate → calcium oxide + carbon dioxide + water

25 What are the uses of the fractions obtained from petroleum?

	gas oil	gasoline	refinery gas
<b>A</b>	cooking	petrol fuel	diesel fuel
<b>B</b>	diesel fuel	heating	petrol fuel
<b>C</b>	diesel fuel	petrol fuel	cooking
<b>D</b>	petrol fuel	diesel fuel	heating



26 Ethene is produced when decane, a large hydrocarbon, is heated with a catalyst.

What is the name of this process?

- A combustion
- B cracking
- C displacement
- D neutralisation

27 Which statement about the manufacture of polymers is correct?

- A Polymers are made by breaking long-chain molecules into shorter chain ones.
- B Polymers are made by joining polymers together.
- C Polymers are made by fractional distillation of petroleum.
- D Polymers are made by joining short-chain molecules together.

28 A solid metal block has a mass of  $2.0 \times 10^4$  kg and a volume of  $2.5 \text{ m}^3$ .

What is the density of the metal?

- A  $800 \text{ kg/m}^3$
- B  $5000 \text{ kg/m}^3$
- C  $8000 \text{ kg/m}^3$
- D  $50000 \text{ kg/m}^3$

29 The diagram shows two teams P and Q pulling on a rope.

Team P pulls with a force of 500 N to the left and team Q pulls with a force of 800 N to the right.

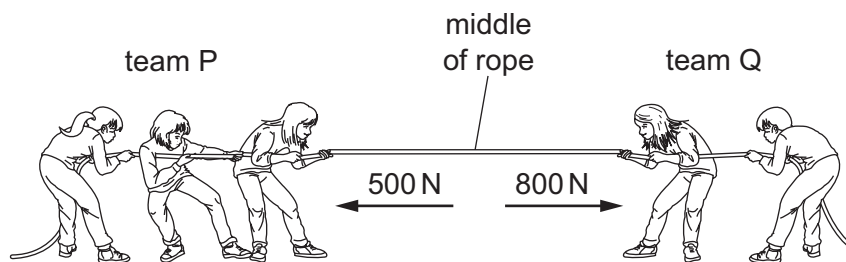

What is the resultant force acting on the middle of the rope?

- A 300 N to the left
- B 300 N to the right
- C 1300 N to the left
- D 1300 N to the right

30 A liquid starts to evaporate.

Which molecules escape, and what happens to the temperature of the remaining liquid?

	molecules that escape	temperature of the remaining liquid
<b>A</b>	less energetic	decreases
<b>B</b>	less energetic	increases
<b>C</b>	more energetic	decreases
<b>D</b>	more energetic	increases

31 A hot water tank is fitted with two identical heaters P and Q. Heater P is fitted above heater Q as shown. The tank is full of cold water.

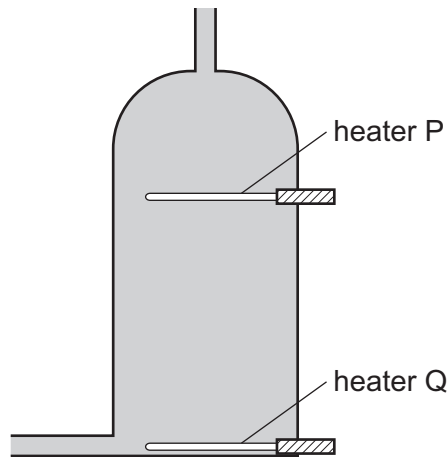

When only heater Q is switched on, it takes a long time to heat the tank of water to 60 °C.

What happens to the cold water when only heater P is switched on?

- A** All the water reaches 60 °C in less time.
- B** All the water reaches 60 °C in the same time.
- C** The water below heater P reaches 60 °C in less time.
- D** The water above heater P reaches 60 °C in less time.

32 'The number of crests on the surface of water that pass a particular point each second.'

Which property of a wave does this describe?

- A** amplitude
- B** frequency
- C** speed
- D** wavelength

33 The diagram shows light passing through a thin converging lens.

At which labelled point is the principal focus of the lens?

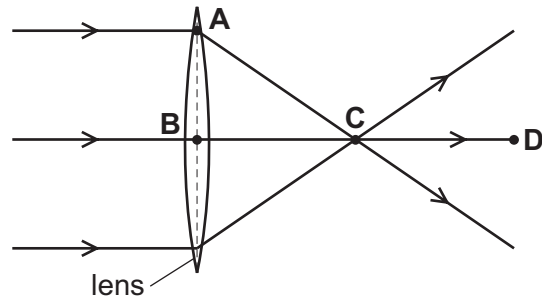

34 The amplitude of a sound wave increases and the frequency decreases.

What happens to the loudness and what happens to the pitch of the sound?

- A The sound becomes louder and higher pitched.
- B The sound becomes louder and lower pitched.
- C The sound becomes quieter and higher pitched.
- D The sound becomes quieter and lower pitched.

35 The circuit shown is used when determining the resistance of a lamp.

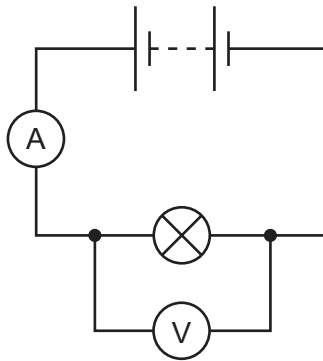

The ammeter reading is 2.0 A and the voltmeter reading is 6.0 V.

What is the resistance of the lamp?

- A  $0.33 \Omega$
- B  $3.0 \Omega$
- C  $8.0 \Omega$
- D  $12 \Omega$

**36** Two resistors of resistance  $1.0\ \Omega$  and  $2.0\ \Omega$  are connected in parallel.

What is the combined resistance of this arrangement of resistors?

- A** less than  $1.0\ \Omega$
- B** exactly  $1.5\ \Omega$
- C** between  $2.0\ \Omega$  and  $3.0\ \Omega$
- D** exactly  $3.0\ \Omega$

**37** A fuse is a safety device for use in an electrical circuit.

The current in the circuit becomes greater than the rated value for the fuse.

What happens?

- A** The current decreases to zero.
- B** The current decreases to the rated value for the fuse.
- C** The thickness of the insulation around the wires increases.
- D** The current is sent to the outer case of the appliance.

38 A current-carrying wire passes through a flat card.

The arrow on each wire shows the direction of the current.

Which diagram shows the pattern of the magnetic field on the card and the direction of the magnetic field lines?

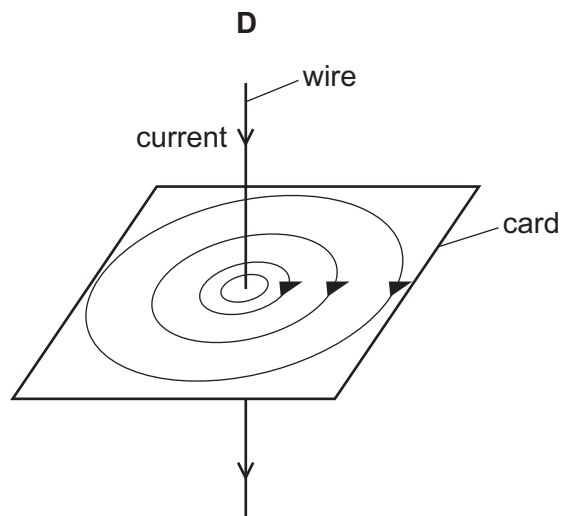
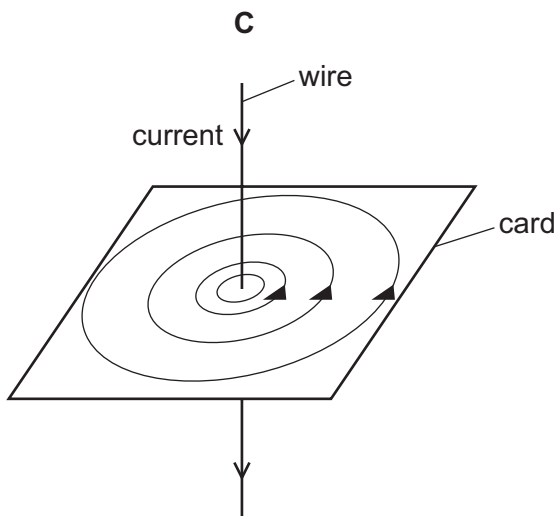
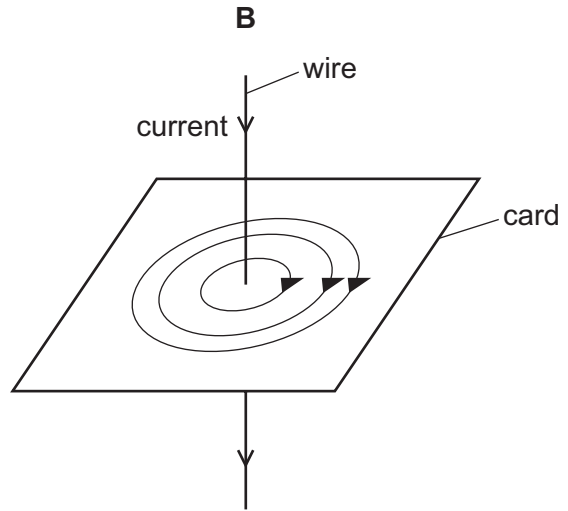
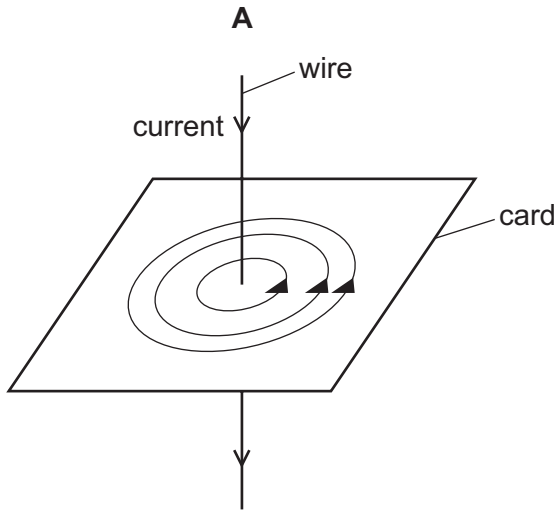

- 39 The diagram shows a current-carrying wire in a magnetic field.

The current and the magnetic field cause a downward force on the wire.

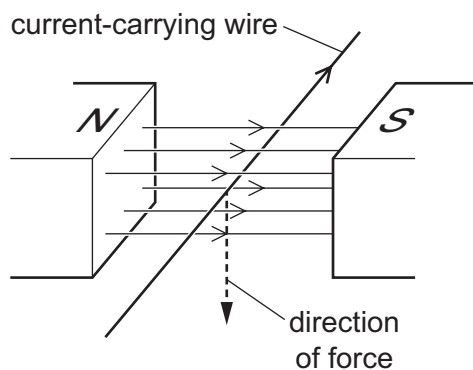

The poles of the magnet are now reversed so that the N-pole is on the right and the S-pole is on the left.

What happens to the force on the wire?

- A Its direction changes.
  - B Its magnitude decreases.
  - C Its magnitude increases.
  - D It is unchanged.
- 40 The diagrams represent the nuclei of four different atoms V, W, X and Y.

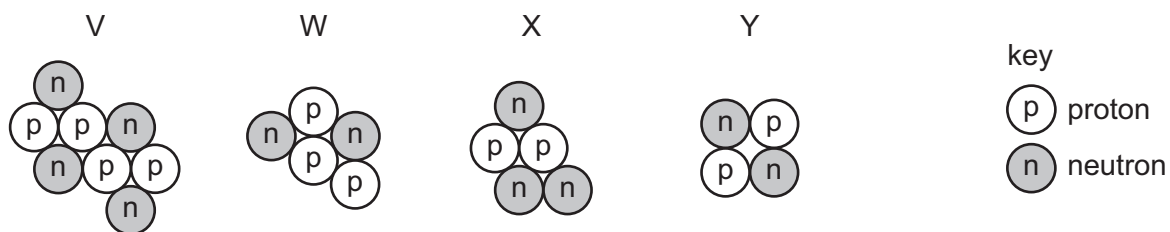

Which two diagrams represent isotopes of the same element?

- A V and Y
- B W and X
- C X and Y
- D Y and W

**BLANK PAGE**

---

Permission to reproduce items where third-party owned material protected by copyright is included has been sought and cleared where possible. Every reasonable effort has been made by the publisher (UCLES) to trace copyright holders, but if any items requiring clearance have unwittingly been included, the publisher will be pleased to make amends at the earliest possible opportunity.

To avoid the issue of disclosure of answer-related information to candidates, all copyright acknowledgements are reproduced online in the Cambridge Assessment International Education Copyright Acknowledgements Booklet. This is produced for each series of examinations and is freely available to download at [www.cambridgeinternational.org](http://www.cambridgeinternational.org) after the live examination series.

Cambridge Assessment International Education is part of the Cambridge Assessment Group. Cambridge Assessment is the brand name of the University of Cambridge Local Examinations Syndicate (UCLES), which itself is a department of the University of Cambridge.

The Periodic Table of Elements

		Group																																																																																
I	II	III	IV	V	VI	VII	VIII																																																																											
3 Li lithium 7	4 Be beryllium 9	11 Na sodium 23	12 Mg magnesium 24	13 Al aluminium 27	14 Si silicon 28	15 P phosphorus 31	16 S sulfur 32	17 Cl chlorine 35.5	18 Ar argon 40	19 K potassium 39	20 Ca calcium 40	21 Sc scandium 45	22 Ti titanium 48	23 V vanadium 51	24 Cr chromium 52	25 Mn manganese 55	26 Fe iron 56	27 Co cobalt 59	28 Ni nickel 59	29 Cu copper 64	30 Zn zinc 65	31 Ga gallium 70	32 Ge germanium 73	33 As arsenic 75	34 Se selenium 79	35 Br bromine 80	36 Kr krypton 84	37 Rb rubidium 85	38 Sr strontium 88	39 Y yttrium 89	40 Zr zirconium 91	41 Nb niobium 93	42 Mo molybdenum 96	43 Tc technetium —	44 Ru ruthenium 101	45 Rh rhodium 103	46 Pd palladium 106	47 Ag silver 108	48 Cd cadmium 112	49 In indium 115	50 Sn tin 119	51 Sb antimony 122	52 Te tellurium 128	53 I iodine 127	54 Xe xenon 131	55 Cs caesium 133	56 Ba barium 137	57–71 lanthanoids	72 Hf hafnium 178	73 Ta tantalum 181	74 W tungsten 184	75 Re rhenium 186	76 Os osmium 190	77 Ir iridium 192	78 Pt platinum 195	79 Au gold 197	80 Hg mercury 201	81 Tl thallium 204	82 Pb lead 207	83 Bi bismuth 209	84 Po polonium —	85 At astatine —	86 Rn radon —	87 Fr francium —	88 Ra radium —	89 Ac actinium —	89–103 actinoids	104 Rf rutherfordium —	105 Db dubnium —	106 Sg seaborgium —	107 Bh bohrium —	108 Hs hassium —	109 Mt meitnerium —	110 Ds darmstadtium —	111 Rg roentgenium —	112 Cn copernicium —	113 Nh nihonium —	114 Fl flerovium —	115 Lv livermorium —	116 Ts tennessine —	117 Og oganesson —	118 Uue unbinilium —

1  
H  
hydrogen  
1

**Key**  
atomic number  
atomic symbol  
name  
relative atomic mass

57 La lanthanum 139	58 Ce cerium 140	59 Pr praseodymium 141	60 Nd neodymium 144	61 Pm promethium —	62 Sm samarium 150	63 Eu europium 152	64 Gd gadolinium 157	65 Tb terbium 159	66 Dy dysprosium 163	67 Ho holmium 165	68 Er erbium 167	69 Tm thulium 169	70 Yb ytterbium 173	71 Lu lutetium 175
89 Ac actinium —	90 Th thorium 232	91 Pa protactinium 231	92 U uranium 238	93 Np neptunium —	94 Pu plutonium —	95 Am americium —	96 Cm curium —	97 Bk berkelium —	98 Cf californium —	99 Es einsteinium —	100 Fm fermium —	101 Md mendelevium —	102 No nobelium —	103 Lr lawrencium —

lanthanoids

actinoids

The volume of one mole of any gas is 24 dm<sup>3</sup> at room temperature and pressure (r.t.p.).