



# Cambridge IGCSE™

CANDIDATE  
NAME

CENTRE  
NUMBER

--	--	--	--	--

CANDIDATE  
NUMBER

--	--	--	--



**COMBINED SCIENCE**

**0653/32**

Paper 3 Theory (Core)

**October/November 2022**

**1 hour 15 minutes**

You must answer on the question paper.

No additional materials are needed.

## INSTRUCTIONS

- Answer **all** questions.
- Use a black or dark blue pen. You may use an HB pencil for any diagrams or graphs.
- Write your name, centre number and candidate number in the boxes at the top of the page.
- Write your answer to each question in the space provided.
- Do **not** use an erasable pen or correction fluid.
- Do **not** write on any bar codes.
- You may use a calculator.
- You should show all your working and use appropriate units.

## INFORMATION

- The total mark for this paper is 80.
- The number of marks for each question or part question is shown in brackets [ ].
- The Periodic Table is printed in the question paper.

This document has **24** pages. Any blank pages are indicated.

1 (a) Fig. 1.1 is a diagram of the alimentary canal and associated organs.

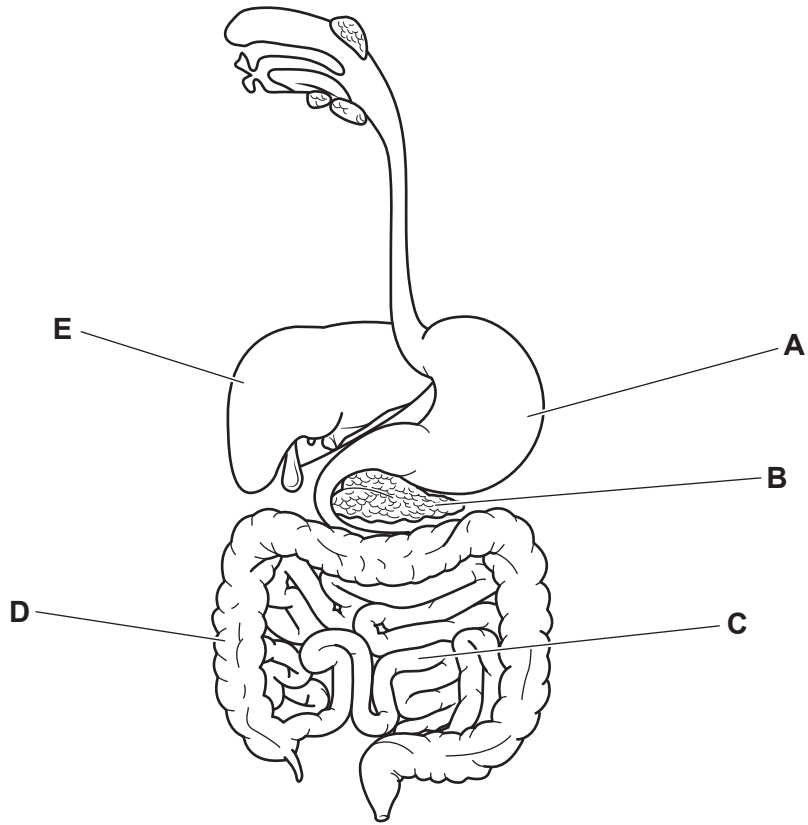

Fig. 1.1

- (i) State the letter in Fig. 1.1 that identifies the liver. .... [1]
- (ii) State the letter in Fig. 1.1 that identifies the pancreas. .... [1]
- (iii) On Fig. 1.1, draw a label line and the letter **S** to show the position of one salivary gland. [1]
- (iv) State the function of salivary glands.  
..... [1]

(b) Starch is a large molecule that is made from smaller molecules.

(i) State the name of the smaller molecules that starch is made from.

..... [1]

(ii) Some starch is mixed with an orange indicator solution, and the indicator solution turns blue-black in colour.

State the name of this indicator solution.

..... [1]

(iii) An enzyme that breaks down starch molecules is added to the mixture of indicator solution and starch.

When the enzyme has broken down all the starch molecules, the mixture turns orange again.

Table 1.1 shows the time taken for the mixture to turn orange at different temperatures.

**Table 1.1**

temperature /°C	time taken for mixture to turn orange /s
25	547
30	279
35	185
40	221
45	485

Use Table 1.1 to describe the effect of temperature on the enzyme activity.

.....  
 .....  
 ..... [2]

[Total: 8]

- 2 (a) A beaker contains a mixture of sodium chloride dissolved in water and iron filings, as shown in Fig. 2.1.

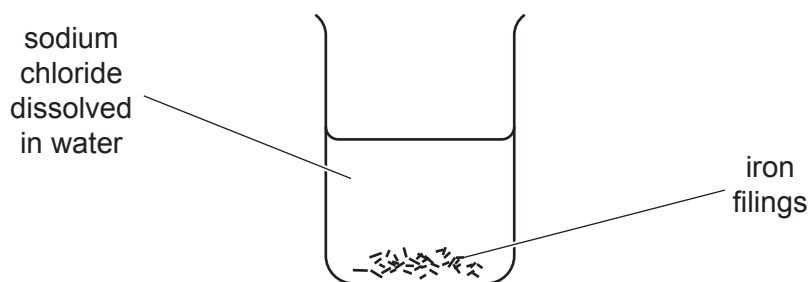

Fig. 2.1

- (i) Identify the solute and the solvent in this mixture.

solute .....

solvent .....

[2]

- (ii) Identify **one** compound in the mixture.

..... [1]

- (iii) State **one** method of removing the iron filings from the mixture.

..... [1]

- (b) When a dilute solution of sodium chloride dissolved in water is heated, evaporation occurs and the solution becomes more concentrated.

State what is meant by more concentrated.

Use ideas about particles in your answer.

.....

..... [1]

- (c) State the products at the anode and at the cathode when concentrated aqueous sodium chloride is electrolysed using inert electrodes.

anode .....

cathode .....

[2]

(d) An atom of iron is represented as shown.

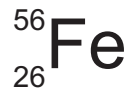

Deduce the number of electrons, protons and neutrons in this atom.

electrons .....

protons .....

neutrons .....

[2]

[Total: 9]

3 In 1997, the Thrust Supersonic Car set a world land speed record.

(a) Fig. 3.1 shows forces **R**, **S**, **V** and **T** acting on the moving car.

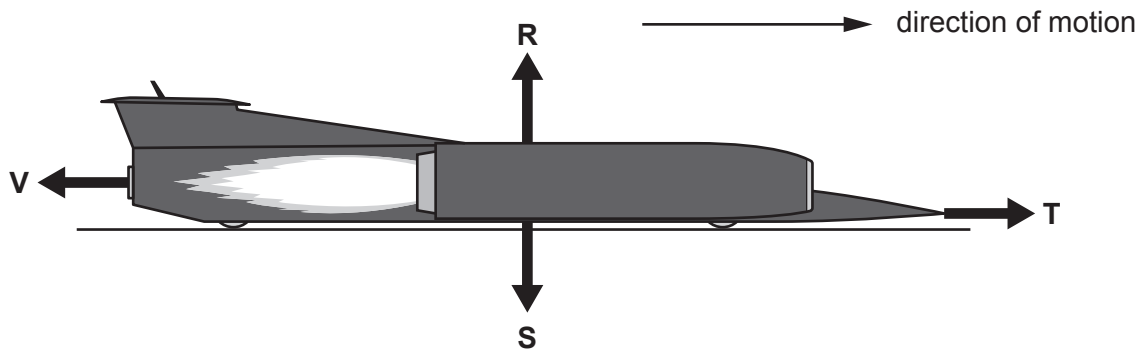

Fig. 3.1

(i) State the name of force **S**. ..... [1]

(ii) The car moves at a constant speed in a straight line along a horizontal track.

Force **T** = 223 000 N.

State the magnitude of force **V**.

force **V** = ..... N [1]

(b) (i) The world land speed record set was 1228 km/h.

Show that the record speed of the car in metres per second is 341 m/s.

[2]

(ii) The car moves a distance of 1609 m at the record speed of 341 m/s.

Calculate the time taken to travel this distance.

time = ..... s [2]

- (c) There is chemical potential energy stored in the fuel of the car. Combustion of the fuel allows the car to accelerate.

Some of this chemical potential energy is transferred to kinetic energy of the moving car.

Suggest **two** other forms of energy to which the chemical potential energy is transferred.

1 .....

2 .....

[2]

- (d) Fig. 3.2 is a speed–time graph for the motion of the car.

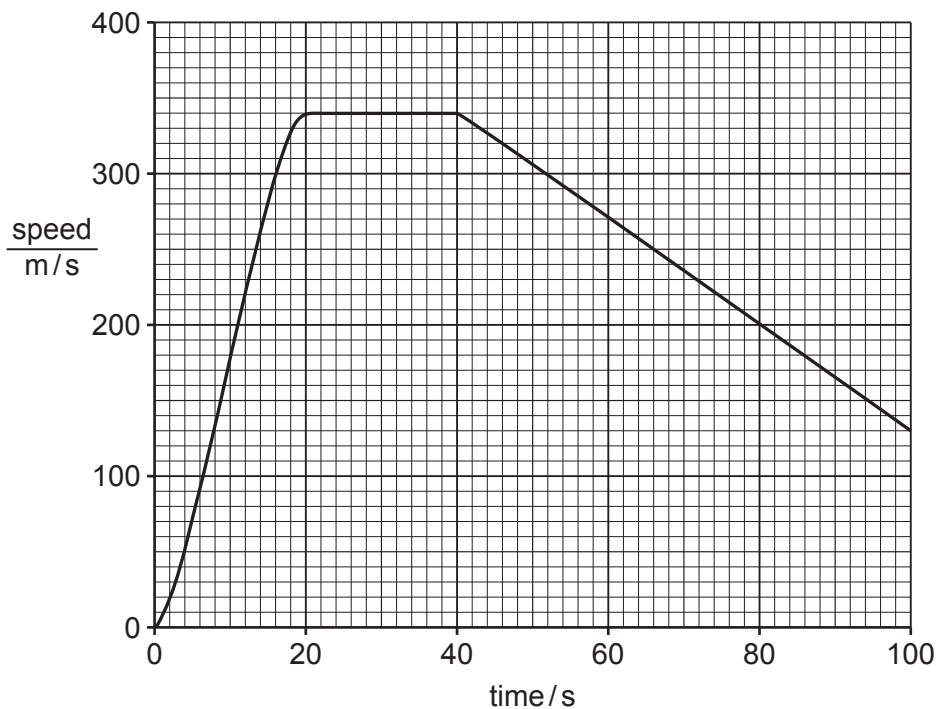

**Fig. 3.2**

Draw **one** straight line from each time period to the matching motion of the car.

**time period**

0–20 s

20–40 s

40–100 s

**motion of the car**

constant speed

deceleration

increasing speed

[2]

[Total: 10]





4 (a) Fig. 4.1 is a photograph of an insect-pollinated flower.



Fig. 4.1

State the functions of the parts labelled X and Y in Fig. 4.1.

X .....

Y ..... [2]

(b) Seeds need a suitable temperature to germinate.

State **two** other environmental conditions needed for germination.

1 .....

2 ..... [2]

(c) Plants transport water from their roots to their leaves.

Water enters the root through root hair cells.

(i) Water then passes into cells inside the root.

Circle the correct name of these cells inside the root.

**cortex**                      **mesophyll**                      **phloem**                      **xylem** [1]

(ii) Water travels up the stem and evaporates from the surface of cells in the leaf.

Circle the correct name of these cells in the leaf.

**cortex**                      **mesophyll**                      **phloem**                      **xylem** [1]

(d) Nutrients from the soil also enter plants through their roots.

The pH of the soil affects the availability of nutrients.

Fig. 4.2 provides data on the effect of soil pH on the availability of six nutrients. The bars show the range of soil pH for which the availability of each nutrient is **maximum**.

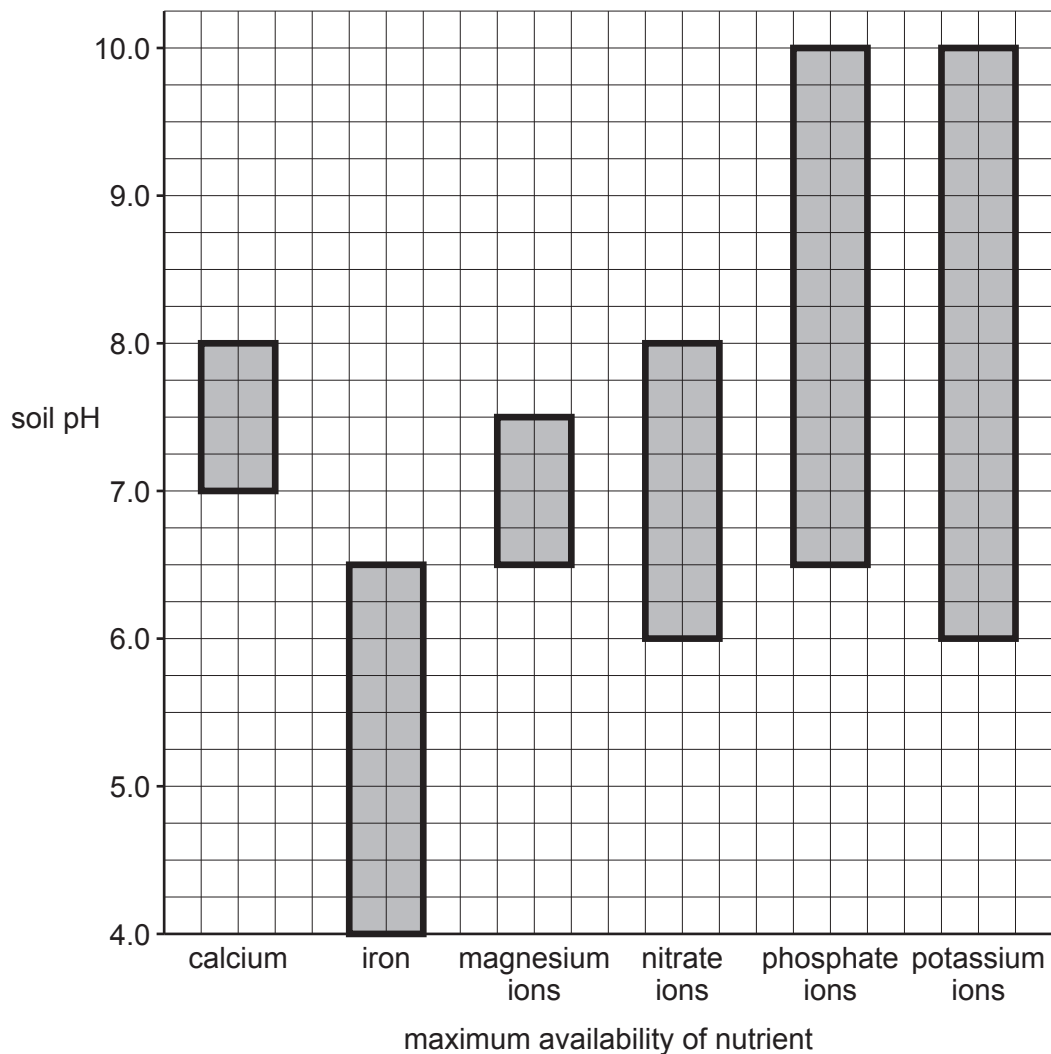

**Fig. 4.2**

The availability of calcium is maximum in soils with a pH between 7.0 and 8.0.

(i) Identify the nutrient in Fig. 4.2 that has maximum availability in a soil of pH 5.5.

..... [1]

- (ii) Use Fig. 4.2 to identify the range of soil pH for which the availability of nitrate ions is maximum.

Place a tick (✓) in **one** box to show the correct answer.

pH4.0–6.0

pH5.0–7.0

pH6.0–8.0

pH7.0–9.0

[1]

- (iii) Plants grown in soils with a pH of 5.0 may have yellow leaves.

Complete the sentences to explain why:

Plants need magnesium ions to make .....

Soils with a pH of 5.0 do **not** have ..... availability of magnesium ions.

[2]

[Total: 10]

- 5 (a) A student investigates the reaction of magnesium with dilute hydrochloric acid, as shown in Fig. 5.1.

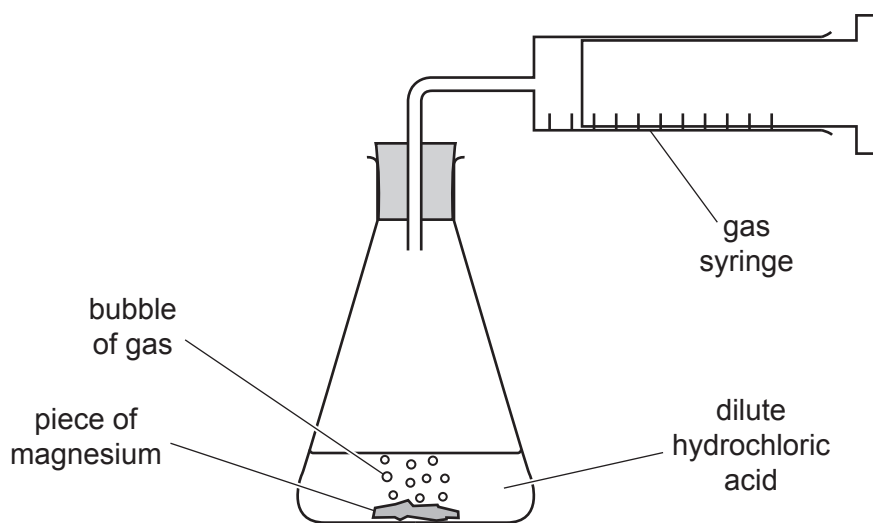
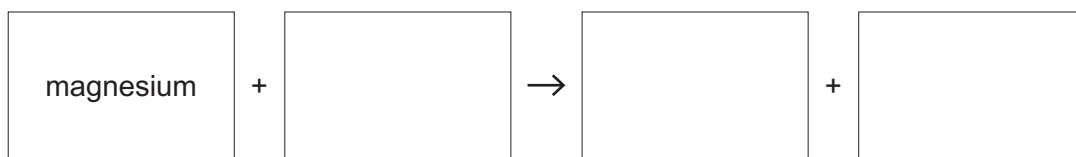

Fig. 5.1

Magnesium chloride and a gas are produced.

- (i) Complete the word equation for this reaction.



[2]

- (ii) Suggest **one** change that can be made to increase the rate of this reaction.

.....  
 ..... [1]

- (iii) Suggest **one** metal that reacts with dilute hydrochloric acid with a lower rate of reaction than magnesium.

..... [1]

- (iv) Magnesium reacts with a different dilute acid to make magnesium sulfate.

State the name of this acid.

..... [1]

- (v) Describe a chemical test for chloride ions and state the positive result.

test .....

.....

result .....

[2]

- (b) The combustion of magnesium in air forms magnesium oxide, MgO.

Magnesium oxide reacts slowly with carbon dioxide in the air to form magnesium carbonate, MgCO<sub>3</sub>, as shown in Fig. 5.2.

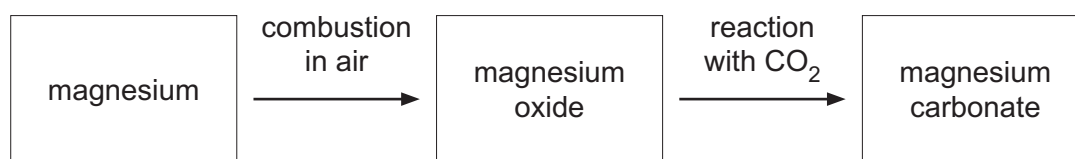

Fig. 5.2

- (i) Explain why the combustion of magnesium is described as oxidation.

.....

..... [1]

- (ii) The combustion of other substances produces carbon dioxide.

State the name of **one** substance that produces carbon dioxide during combustion.

..... [1]

- (iii) Carbon dioxide is a greenhouse gas.

State the name of **one** other greenhouse gas.

..... [1]

[Total: 10]

- 6 (a) Fig. 6.1 shows an electric heater with two heating elements connected in series to a 240V supply.

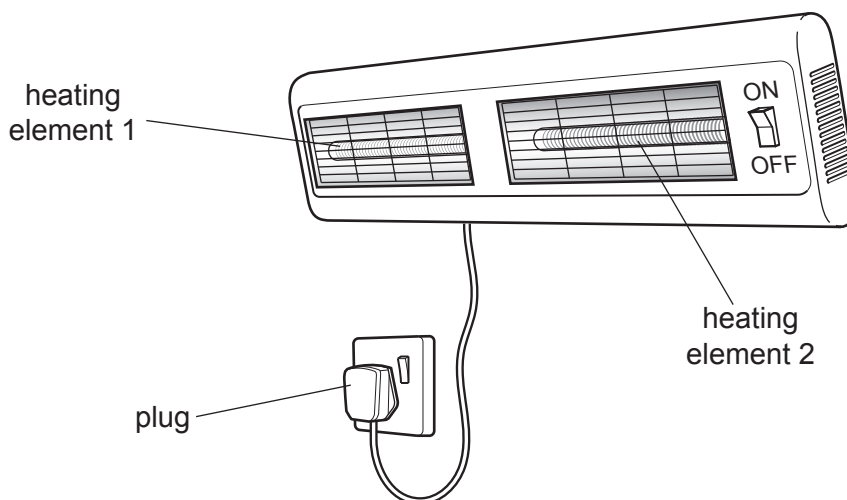

Fig. 6.1

Fig. 6.2 shows the circuit diagram for the heater with two ammeters added into the circuit.

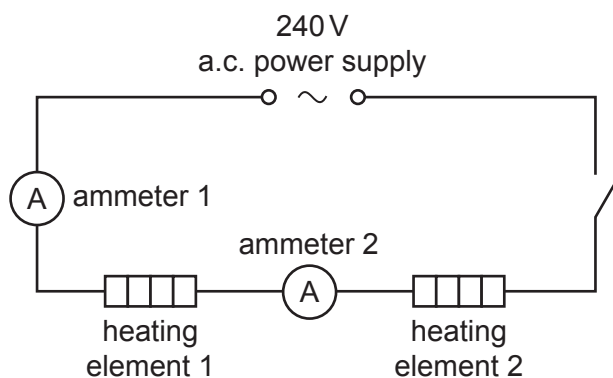

Fig. 6.2

- (i) The plug to the heater has a fuse.

Draw the circuit symbol for a fuse.

[1]

- (ii) Ammeters are used to measure current.

State the name of the unit of current.

..... [1]

(iii) Ammeter 1 shows a reading of 5.4A.

Circle the reading that is shown on ammeter 2.

Give a reason for your answer.

2.7A

5.4A

10.8A

reason .....

.....

[1]

(iv) Heating element 1 has a resistance of 30  $\Omega$ .

Heating element 2 has a resistance of 15  $\Omega$ .

Calculate the combined resistance of the two heating elements.

resistance = .....  $\Omega$  [1]

(b) Fig. 6.3 shows the circuit diagram for a different electric heater.

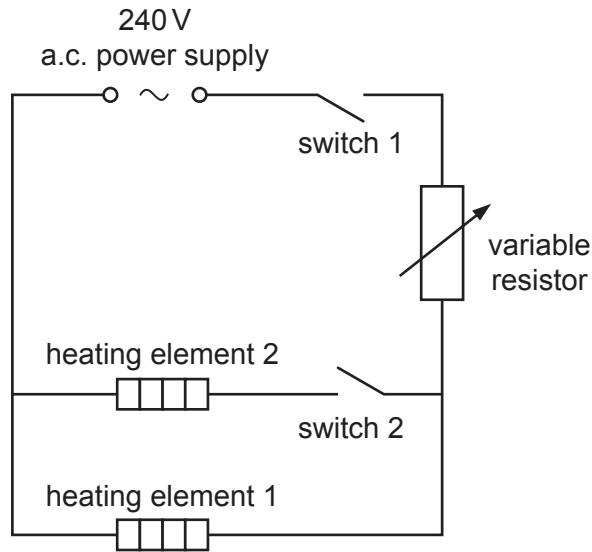

**Fig. 6.3**

Heating element 1 is switched ON.

Heating element 2 is switched OFF.

The variable resistor is set to zero resistance.

(i) State whether switch 1 and switch 2 are OPEN or CLOSED.

switch 1 .....

switch 2 .....

[1]

(ii) The resistance of the variable resistor is increased from zero.

State the effect this has on the current in heating element 1.

Explain your answer.

current .....

explanation .....

.....

[1]



(iii) Heating element 2 is now also switched ON.

The variable resistor is **not** changed.

Explain why the current from the source increases.

.....  
..... [1]

(iv) The two heating elements are connected in parallel with the 240V supply.

Suggest **one** advantage of connecting the heating elements in parallel in the circuit.

.....  
..... [1]

[Total: 8]

7 (a) The boxes on the left show some of the characteristics of living organisms.

The boxes on the right show the definitions of these characteristics.

Draw **one** straight line from each characteristic to its definition.

**characteristic**

**definition**

excretion

ability to detect and respond to changes in the environment

growth

permanent increase in size

sensitivity

removal from organisms of toxic materials and substances in excess of requirements

[2]

(b) Respiration and movement are two more characteristics of living organisms.

Explain why respiration is needed for movement.

.....

.....

..... [2]

(c) Fig. 7.1 shows cells from an organ in the human body.

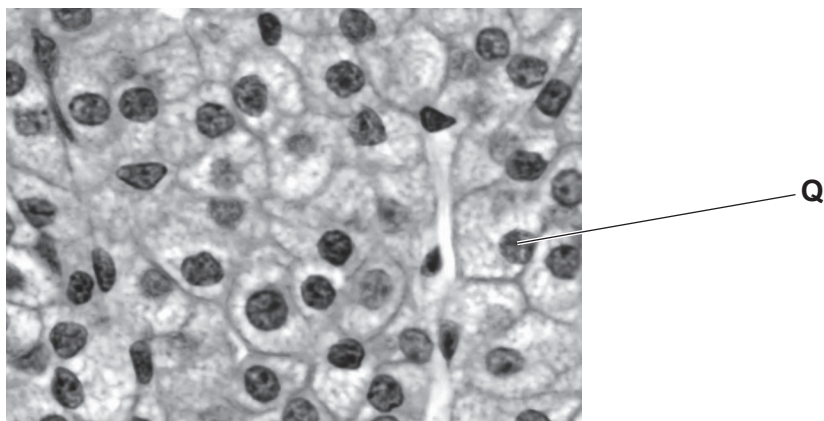

**Fig. 7.1**

(i) Identify the structure labelled **Q** on Fig. 7.1.

..... [1]

(ii) The organ produces a hormone.

Describe how hormones are transported around the body.

..... [1]

(d) (i) Complete this sentence about diffusion.

Diffusion is the net movement of particles down a .....

gradient as a result of their ..... movement.

[2]

(ii) Water diffuses through partially permeable membranes.

State the name of this type of diffusion.

..... [1]

[Total: 9]

8 Part of the Periodic Table of Elements is shown in Fig. 8.1.

Group																	
I	II											III	IV	V	VI	VII	VIII
										H hydrogen							He helium
Li lithium	Be beryllium											B boron	C carbon	N nitrogen	O oxygen	F fluorine	Ne neon
Na sodium	Mg magnesium											Al aluminium	Si silicon	P phosphorus	S sulfur	Cl chlorine	Ar argon
K potassium	Ca calcium	Sc scandium	Ti titanium	V vanadium	Cr chromium	Mn manganese	Fe iron	Co cobalt	Ni nickel	Cu copper	Zn zinc	Ga gallium	Ge germanium	As arsenic	Se selenium	Br bromine	Kr krypton

Fig. 8.1

(a) State the trend in the character of the elements across the Periodic Table from left to right.

..... [1]

(b) Element X conducts electricity and has a high density.

Element Y is soft and conducts electricity.

Use Fig. 8.1 to suggest the names of element X and element Y.

X ..... Y ..... [2]

(c) Iron rusts when it reacts with oxygen and one other substance.

(i) State the percentage of oxygen in clean air. ....% [1]

(ii) Identify the other substance required for the rusting of iron. .... [1]

(d) Argon is a monoatomic, unreactive Group VIII gas.

(i) State what is meant by monoatomic.

..... [1]

(ii) Explain why argon is unreactive.

Use ideas about electronic structure in your answer.

.....  
 ..... [1]

[Total: 7]

9 Fig. 9.1 shows a ship at sea.

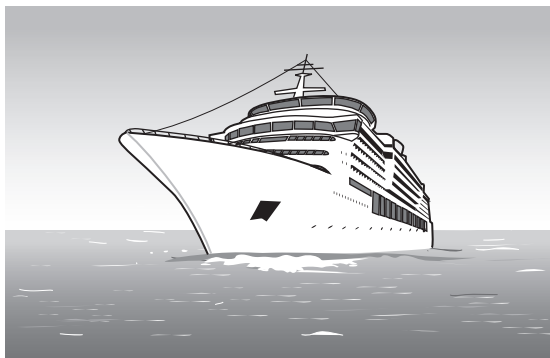

**Fig. 9.1**

- (a) The ship uses radio waves to communicate with other ships.  
Radio waves are one region of the electromagnetic spectrum.
- (i) Fig. 9.2 shows an incomplete electromagnetic spectrum.  
On Fig. 9.2, write radio waves in the correct place.

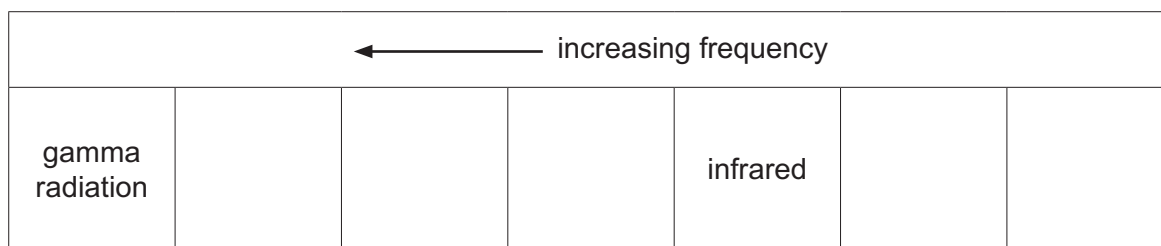

**Fig. 9.2**

[1]

- (ii) Complete the sentences about frequency.

The frequency of a wave is the ..... of waves passing a point in space per second.

The unit of frequency is .....

[2]

(b) Fig. 9.3 shows solar panels on the boat.

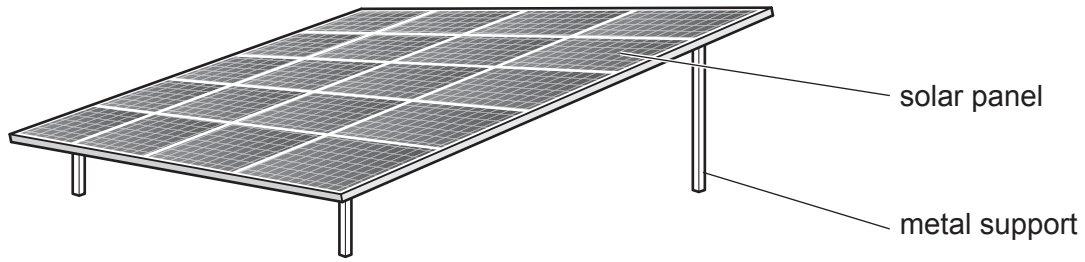

**Fig. 9.3**

The solar panels generate electricity using light from the Sun.

Energy from the Sun makes the solar panels hot to touch.

(i) State the method of energy transfer from the Sun through space.

..... [1]

(ii) The solar panels are fixed to metal supports underneath.

The Sun does **not** shine directly onto the metal supports, but the metal supports also become hot to touch.

State the main method of energy transfer from the solar panels to the metal supports.

..... [1]

(iii) Solar panels are a source of renewable energy.

Select from the list **two** other sources of renewable energy.

- |                |                   |                      |
|----------------|-------------------|----------------------|
| <b>coal</b>    | <b>geothermal</b> | <b>hydroelectric</b> |
| <b>nuclear</b> | <b>petroleum</b>  | <b>tidal</b>         |

1 .....

2 .....

[2]

(iv) Fig. 9.4 shows three rays of light entering a thin converging lens.

Point **F** is the principal focus of the lens.

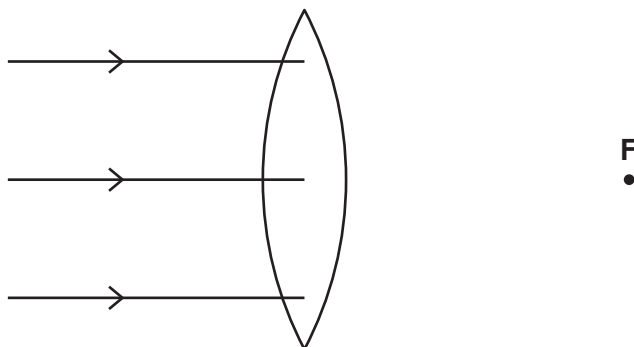

**Fig. 9.4**

On Fig. 9.4, complete the ray diagram to show how the three rays are focused. [2]

[Total: 9]

---

Permission to reproduce items where third-party owned material protected by copyright is included has been sought and cleared where possible. Every reasonable effort has been made by the publisher (UCLES) to trace copyright holders, but if any items requiring clearance have unwittingly been included, the publisher will be pleased to make amends at the earliest possible opportunity.

To avoid the issue of disclosure of answer-related information to candidates, all copyright acknowledgements are reproduced online in the Cambridge Assessment International Education Copyright Acknowledgements Booklet. This is produced for each series of examinations and is freely available to download at [www.cambridgeinternational.org](http://www.cambridgeinternational.org) after the live examination series.

Cambridge Assessment International Education is part of Cambridge Assessment. Cambridge Assessment is the brand name of the University of Cambridge Local Examinations Syndicate (UCLES), which is a department of the University of Cambridge.

## The Periodic Table of Elements

		Group																																
I	II	III	IV	V	VI	VII	VIII																											
3 <b>Li</b> lithium 7	4 <b>Be</b> beryllium 9	1 <b>H</b> hydrogen 1	5 <b>B</b> boron 11	6 <b>C</b> carbon 12	7 <b>N</b> nitrogen 14	8 <b>O</b> oxygen 16	9 <b>F</b> fluorine 19	10 <b>Ne</b> neon 20																										
11 <b>Na</b> sodium 23	12 <b>Mg</b> magnesium 24	<b>Key</b> atomic number atomic symbol name relative atomic mass																																
19 <b>K</b> potassium 39	20 <b>Ca</b> calcium 40											13 <b>Al</b> aluminium 27	14 <b>Si</b> silicon 28	15 <b>P</b> phosphorus 31	16 <b>S</b> sulfur 32	17 <b>Cl</b> chlorine 35.5	18 <b>Ar</b> argon 40																	
37 <b>Rb</b> rubidium 85	38 <b>Sr</b> strontium 88	21 <b>Sc</b> scandium 45	22 <b>Ti</b> titanium 48	23 <b>V</b> vanadium 51	24 <b>Cr</b> chromium 52	25 <b>Mn</b> manganese 55	26 <b>Fe</b> iron 56	27 <b>Co</b> cobalt 59	28 <b>Ni</b> nickel 59	29 <b>Cu</b> copper 64	30 <b>Zn</b> zinc 65	31 <b>Ga</b> gallium 70	32 <b>Ge</b> germanium 73	33 <b>As</b> arsenic 75	34 <b>Se</b> selenium 79	35 <b>Br</b> bromine 80	36 <b>Kr</b> krypton 84																	
55 <b>Cs</b> caesium 133	56 <b>Ba</b> barium 137	39 <b>Y</b> yttrium 89	40 <b>Zr</b> zirconium 91	41 <b>Nb</b> niobium 93	42 <b>Mo</b> molybdenum 96	43 <b>Tc</b> technetium —	44 <b>Ru</b> ruthenium 101	45 <b>Rh</b> rhodium 103	46 <b>Pd</b> palladium 106	47 <b>Ag</b> silver 108	48 <b>Cd</b> cadmium 112	49 <b>In</b> indium 115	50 <b>Sn</b> tin 119	51 <b>Sb</b> antimony 122	52 <b>Te</b> tellurium 128	53 <b>I</b> iodine 127	54 <b>Xe</b> xenon 131	55 <b>Po</b> polonium 209	56 <b>At</b> astatine —															
87 <b>Fr</b> francium —	88 <b>Ra</b> radium —	57–71 lanthanoids	72 <b>Hf</b> hafnium 178	73 <b>Ta</b> tantalum 181	74 <b>W</b> tungsten 184	75 <b>Re</b> rhenium 186	76 <b>Os</b> osmium 190	77 <b>Ir</b> iridium 192	78 <b>Pt</b> platinum 195	79 <b>Au</b> gold 197	80 <b>Hg</b> mercury 201	81 <b>Tl</b> thallium 204	82 <b>Pb</b> lead 207	83 <b>Bi</b> bismuth 209	84 <b>Po</b> polonium —	85 <b>At</b> astatine —	86 <b>Rn</b> radon —	87 <b>Lr</b> lawrencium —	88 <b>Lu</b> lutetium 175	89 <b>Ac</b> actinium —	90 <b>Th</b> thorium 232	91 <b>Pa</b> protactinium 231	92 <b>U</b> uranium 238	93 <b>Np</b> neptunium —	94 <b>Pu</b> plutonium —	95 <b>Am</b> americium —	96 <b>Cm</b> curium —	97 <b>Bk</b> berkelium —	98 <b>Cf</b> californium —	99 <b>Es</b> einsteinium —	100 <b>Fm</b> fermium —	101 <b>Md</b> mendelevium —	102 <b>No</b> nobelium —	103 <b>Lr</b> lawrencium —

57 <b>La</b> lanthanum 139	58 <b>Ce</b> cerium 140	59 <b>Pr</b> praseodymium 141	60 <b>Nd</b> neodymium 144	61 <b>Pm</b> promethium —	62 <b>Sm</b> samarium 150	63 <b>Eu</b> europium 152	64 <b>Gd</b> gadolinium 157	65 <b>Tb</b> terbium 159	66 <b>Dy</b> dysprosium 163	67 <b>Ho</b> holmium 165	68 <b>Er</b> erbium 167	69 <b>Tm</b> thulium 169	70 <b>Yb</b> ytterbium 173	71 <b>Lu</b> lutetium 175
89 <b>Ac</b> actinium —	90 <b>Th</b> thorium 232	91 <b>Pa</b> protactinium 231	92 <b>U</b> uranium 238	93 <b>Np</b> neptunium —	94 <b>Pu</b> plutonium —	95 <b>Am</b> americium —	96 <b>Cm</b> curium —	97 <b>Bk</b> berkelium —	98 <b>Cf</b> californium —	99 <b>Es</b> einsteinium —	100 <b>Fm</b> fermium —	101 <b>Md</b> mendelevium —	102 <b>No</b> nobelium —	103 <b>Lr</b> lawrencium —

lanthanoids

actinoids

The volume of one mole of any gas is 24 dm<sup>3</sup> at room temperature and pressure (r.t.p.).