



Cambridge International Examinations
Cambridge International General Certificate of Secondary Education

PHYSICS

0625/53

Paper 5 Practical Test

May/June 2015

CONFIDENTIAL INSTRUCTIONS

Great care should be taken to ensure that any confidential information given does not reach the candidates either directly or indirectly.



If you have any problems or queries regarding these Instructions, please contact CIE
by e-mail: info@cie.org.uk,
by phone: +44 1223 553554,
by fax: +44 1223 553558,
stating the Centre number, the nature of the query and the syllabus number quoted above.

bestexamhelp.com

The syllabus is approved for use in England, Wales and Northern Ireland as a Cambridge International Level 1/Level 2 Certificate.

This document consists of **10** printed pages and **2** blank pages.

Instructions for preparing apparatus

The Supervisor is **not** allowed to consult the Question Paper before the examination. This teacher should, as part of the preparation of the examination requirements, test the apparatus in order to ensure that it is satisfactory.

The Supervisor is asked to give (and attach to the Report form printed on pages 11 and 12) a *brief* description of the apparatus supplied, mentioning any points that are likely to be of importance to the Examiner in marking the answers. The Supervisor should also report any assistance given to candidates. All reports should be signed by the Supervisor and by the person responsible for preparing the apparatus.

In addition to the usual equipment of a physics laboratory, each candidate will require the apparatus specified in these Instructions. If a candidate breaks any of the apparatus, or loses any of the material supplied, the matter should be rectified and a note made in the Report.

Number of sets of apparatus

As a *minimum*, the number of sets of apparatus provided should be $N/4$, where N is the number of candidates (per session). A few spare sets should, preferably, be available to avoid any candidate being delayed when moving to another question.

Centres may find it more convenient and easier to administer if $N/3$ sets (plus one or two 'spares') of apparatus are provided.

The order in which a given candidate attempts the four questions is immaterial.

Assistance to Candidates

The purpose of the Practical Physics test is to find out whether the candidates can carry out simple practical work themselves. The Examiners are aware that candidates may sometimes be unable to show their practical ability through failure to understand some point in the theory of the experiment. If an Examiner were present in the laboratory, he/she would be willing to give a hint to enable such a candidate to get on with an experiment. In order to overcome this difficulty, the Supervisor is asked to co-operate with the Examiners to the extent of being ready to give (or allow the Physics teacher to give) a hint to a candidate who is unable to proceed.

The following regulations must be strictly adhered to.

- (i) No hint may be announced to the candidates as a whole.
- (ii) A candidate who is unable to proceed and requires assistance must come up to the Supervisor and state the difficulty. Candidates should be told that the Examiners will be informed of any assistance given in this way.
- (iii) A report must be made of any assistance given to the candidate, with the name and candidate number of the candidate.

It is suggested that the following announcement be made to the candidates.

'The Examiners do not want you to waste time through inability to get on with an experiment. Any candidate, therefore, who is unable to get on with the experiment after spending five minutes at it may come to me and ask for help. I shall report to the Examiners any help given in this way, and some marks may be lost for the help given. You may ask me for additional apparatus which you think would improve the accuracy of your experiments, and you should say, on your script, how you use any such apparatus supplied.'

Question 1

Items to be supplied by the Centre (per set of apparatus unless otherwise specified).

- (i) 2 pieces of thin string, each approximately 55 cm long. See note 1.
- (ii) 2 pieces of thin string made into loops and labelled **P** and **Q**. See note 3. Cotton is not suitable as it tangles easily.
- (iii) 100 g mass attached to one of the 55 cm strings. See note 1.
- (iv) Object of mass approximately 150 g, labelled **X**, attached to the other 55 cm string. See notes 1 and 2.
- (v) Metre rule. See note 1.
- (vi) 4 clamps, 4 bosses and 2 stands. See note 1.
- (vii) 50 cm or 30 cm ruler graduated in mm. Candidates may use their own.

Notes

1. The apparatus should be set up for candidates as shown in Fig. 1.1.

The rule must be clamped securely so that the stands remain the same distance apart during the experiment. It must be horizontal and approximately 25 cm below the upper clamp, with the scale facing the candidate. It may be necessary to increase the stability of the clamp stands (for example, by using a G clamp or by placing a weight on the base).

The vertical strings should be approximately 50 cm apart and must be suspended from the same height above the bench. It is not important that they are identical in length but there should be approximately 25 cm of each string below the rule. The strings must be arranged so that they hang just in front of the rule and so that the scale can be easily read at that point. This may be most easily achieved by arranging the clamps at opposite sides of the stands as indicated in Fig. 1.1.

The masses must hang freely and be clear of the bench and stand bases. If necessary, the masses may hang below the bench level.

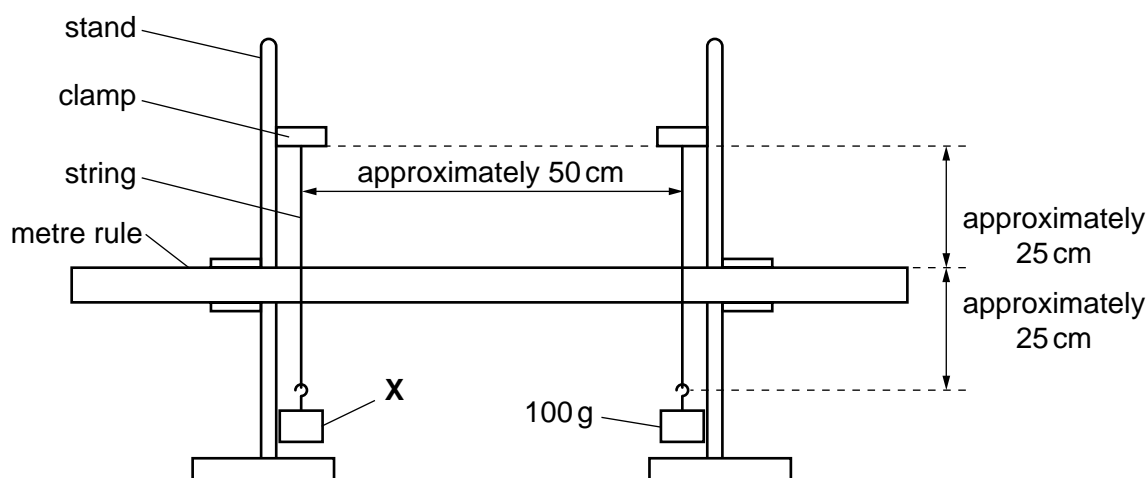

Fig. 1.1

- Object **X** must be made up in such a way that candidates cannot easily detect its value. A 100g mass hanger with added modelling clay is suitable.
- The loops should have approximate dimensions as shown in Fig. 1.2.

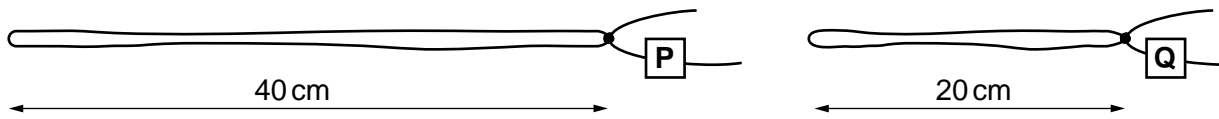

Fig. 1.2

Action at changeover

Remove the loop from the vertical strings if necessary.

Check that the metre rule is clamped as shown in Fig. 1.1 and that the loops are intact.

Question 2

Items to be supplied by the Centre (per set of apparatus unless otherwise specified).

- (i) 250 cm³ beaker. See note 1.
- (ii) Thermometer: –10 °C to 110 °C, graduated in 1 °C intervals. See note 1.
- (iii) Stopclock or stopwatch or wall-mounted clock showing seconds. Candidates will be required to take readings at 30-second intervals. They may use their own wristwatches. The question will refer to a stopclock.
- (iv) Supply of hot water. See notes 2 and 3.
- (v) Paper towels to soak up any water spillages.
- (vi) Spare beakers and thermometers.

Notes

1. The beaker and thermometer should be supplied to candidates as shown in Fig. 2.1, without water in the beaker. If the beaker does not have graduations, an indelible mark must be made at the 100 cm³ level and labelled '100 cm³'.

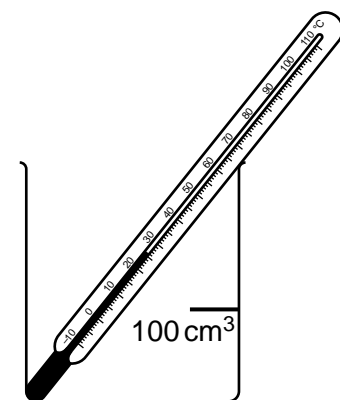

Fig. 2.1

2. The hot water is to be supplied for each candidate by the Supervisor. The water temperature should be between 80 °C and 100 °C. Each candidate will require approximately 150 cm³ of hot water. They must be able to pour hot water into the beaker safely.
3. Candidates should be warned of the dangers of burns and scalds when using very hot water.

Action at changeover

Empty the water from the beaker.

Check that the apparatus is intact and arrange as shown in Fig. 2.1.

Question 3

Items to be supplied by the Centre (per set of apparatus unless otherwise specified).

- (i) A resistance wire approximately 1 m in length. 32 swg (0.274 mm diameter) constantan (eureka) or any other wire with a resistance of approximately $8\ \Omega\ \text{m}^{-1}$ is suitable. See note 1.
- (ii) Metre rule. See note 1.
- (iii) Power supply of approximately 2 to 3V. See note 3. Where candidates are provided with a variable power supply, the voltage should be set by the Supervisor and fixed, e.g. taped.
- (iv) Switch. The switch may be an integral part of the power supply.
- (v) Sufficient connecting leads to set up the circuit shown in Fig. 3.1.
- (vi) Crocodile clip. A jockey is a suitable alternative. The question will refer to a crocodile clip.
- (vii) Ammeter capable of measuring currents up to 1.00A with a minimum resolution of 0.05A. See note 4.
- (viii) Voltmeter capable of measuring up to 3.0V with a minimum resolution of 0.1V. See note 4.
- (ix) Spare leads and crocodile clips.

Notes

1. The wire is to be fixed to a metre rule in such a way as to allow candidates to connect a crocodile clip to points between the 50 cm and 90 cm marks. Alternatively, a potentiometer fitted with an appropriate wire is suitable. The wire must be taped over with transparent tape between the 0 cm and 49 cm marks to prevent connection to this section. The end of the wire at the 0 cm end of the rule must be labelled T.
2. The circuit is to be set up for candidates as shown in Fig. 3.1, with the crocodile clip not connected to the wire.

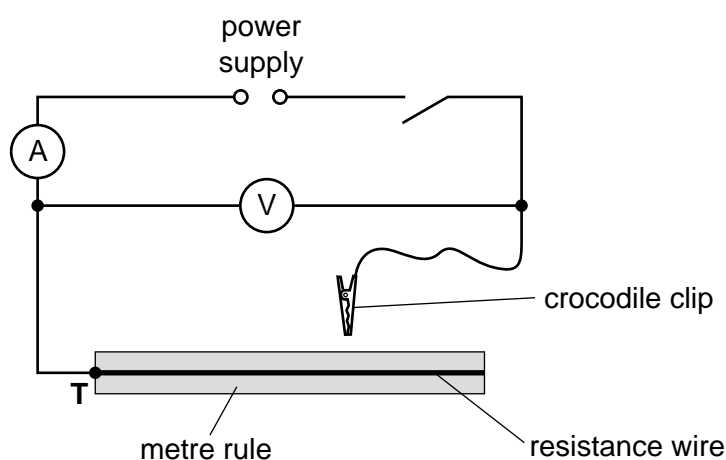

Fig. 3.1

3. If cells are used, they must remain adequately charged throughout the examination. Spare cells must be available.
4. Either analogue or digital meters are suitable. Any variable settings should be set by the Supervisor and fixed, e.g. taped. Spare meters must be available.

Action at changeover

Ensure that the circuit is connected as shown in Fig. 3.1. Check that it is working, by connecting the crocodile clip at the 90 cm mark.

Disconnect the crocodile clip from the resistance wire and ensure that the circuit is switched off.

Question 4

Items to be supplied by the Centre (per set of apparatus unless otherwise specified).

- (i) Converging lens of focal length approximately 15 cm with a suitable holder. See note 2.
- (ii) Metre rule.
- (iii) Plane mirror capable of standing vertically. See note 2.
- (iv) Illuminated object consisting of a white rigid card with a triangular hole of height approximately 2 cm. See Fig. 4.1 and notes 1 and 2. The back of the hole is to be covered with thin translucent paper (e.g. tracing paper) secured with adhesive tape. The front of the card forming the object should be white or light in colour.
- (v) Screen. A white sheet of stiff card approximately 15 cm × 15 cm, fixed to a wooden support is suitable. See Fig. 4.2.

Notes

1. The lamp used for the illuminated object should be low voltage, 24W or greater, with a suitable power supply.
2. The lamp filament, the centre of the hole which forms the object and the centre of the lens in its holder must all be the same height above the bench. The top of the plane mirror must reach at least this height.
3. The work station should be situated away from direct sunlight.

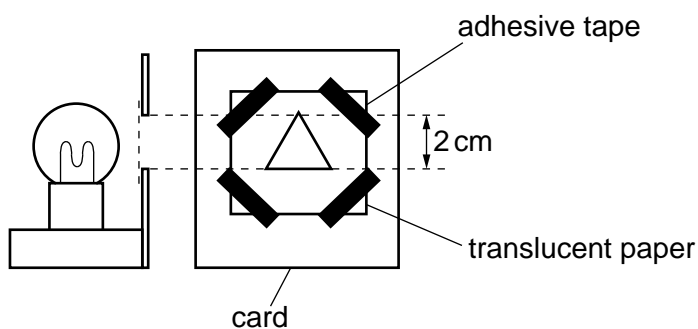

Fig. 4.1

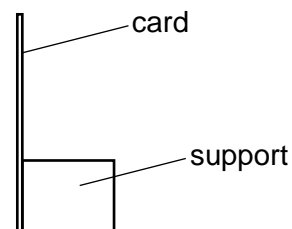

Fig. 4.2

Action at changeover

Check that the lamp works.

BLANK PAGE

BLANK PAGE

Permission to reproduce items where third-party owned material protected by copyright is included has been sought and cleared where possible. Every reasonable effort has been made by the publisher (UCLES) to trace copyright holders, but if any items requiring clearance have unwittingly been included, the publisher will be pleased to make amends at the earliest possible opportunity.

To avoid the issue of disclosure of answer-related information to candidates, all copyright acknowledgements are reproduced online in the Cambridge International Examinations Copyright Acknowledgements Booklet. This is produced for each series of examinations and is freely available to download at www.cie.org.uk after the live examination series.

Cambridge International Examinations is part of the Cambridge Assessment Group. Cambridge Assessment is the brand name of University of Cambridge Local Examinations Syndicate (UCLES), which is itself a department of the University of Cambridge.

This form must be completed and returned with the scripts.

REPORT ON PRACTICAL PHYSICS

(IGCSE MAY/JUNE 2015)

General

The Supervisor is required to give details of any difficulties experienced by particular candidates giving their names and candidate numbers. These should include reference to:

- (a) difficulties due to faulty apparatus;
- (b) accidents to apparatus or materials;
- (c) any other information that is likely to assist the Examiner, especially if this cannot be discovered in the scripts;
- (d) any help given to a candidate.

Information required

A plan of workbenches, giving details by candidate number of the places occupied by the candidates for each experiment for each session, must be enclosed with the scripts.

The space below can be used for this, or it may be on separate paper.



Information required (cont.)

A list by name and candidate number of candidates requiring help, with details of the help provided.

CENTRE NO.

NAME OF CENTRE

Declaration (to be signed by the Supervisor and the person responsible for preparing the apparatus)

The preparation of the practical examination has been carried out so as to maintain fully the security of the examination.

SIGNED
Supervisor

SIGNED
Person responsible for preparing the apparatus

