



UNIVERSITY OF CAMBRIDGE INTERNATIONAL EXAMINATIONS  
International General Certificate of Secondary Education

**PHYSICS**

**0625/13**

Paper 1 Multiple Choice

**October/November 2013**

**45 minutes**

Additional Materials: Multiple Choice Answer Sheet  
Soft clean eraser  
Soft pencil (type B or HB recommended)

\* 1 7 2 8 1 5 9 1 4 1 \*

**READ THESE INSTRUCTIONS FIRST**

Write in soft pencil.

Do not use staples, paper clips, highlighters, glue or correction fluid.

Write your name, Centre number and candidate number on the Answer Sheet in the spaces provided unless this has been done for you.

**DO NOT WRITE IN ANY BARCODES.**

There are **forty** questions on this paper. Answer **all** questions. For each question there are four possible answers **A, B, C** and **D**.

Choose the **one** you consider correct and record your choice in **soft pencil** on the separate Answer Sheet.

**Read the instructions on the Answer Sheet very carefully.**

Each correct answer will score one mark. A mark will not be deducted for a wrong answer.

Any rough working should be done in this booklet.

Electronic calculators may be used.

bestexamhelp.com

This document consists of **19** printed pages and **1** blank page.



- 1 A cyclist rides round a track three times.

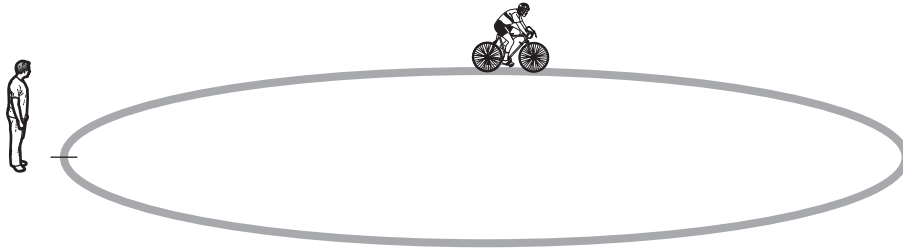

Her friend uses a stopwatch to record the time at the start of the ride, after one circuit, and at the end of the three circuits. The readings from the stopwatch are shown.



at the  
start



after  
one circuit



at the end of  
three circuits

What is the average time for one circuit of the track?

- A** 174 s      **B** 180 s      **C** 198 s      **D** 200 s
- 2 The graph shows how the distance travelled by a vehicle changes with time.

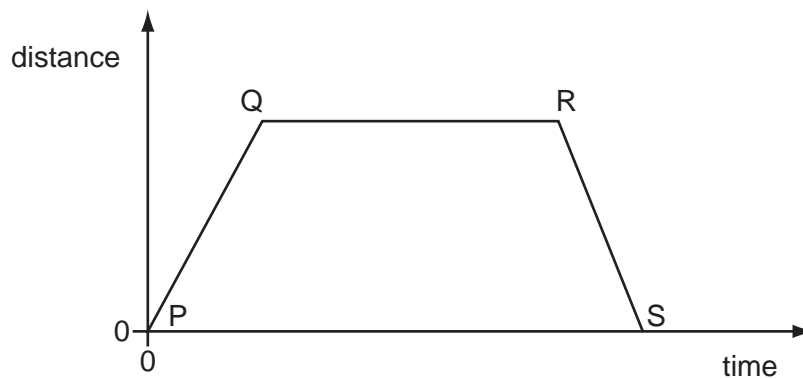

Which row describes the speed of the vehicle in each section of the graph?

	P to Q	Q to R	R to S
<b>A</b>	constant	zero	constant
<b>B</b>	constant	zero	decreasing
<b>C</b>	increasing	constant	decreasing
<b>D</b>	increasing	zero	decreasing

- 3 A small steel ball is dropped from a low balcony.

Ignoring air resistance, which statement describes its motion?

- A It falls with constant acceleration.
- B It falls with constant speed.
- C It falls with decreasing speed.
- D It falls with increasing acceleration.

- 4 Which is the unit for force and which is the unit for weight?

	force	weight
<b>A</b>	kg	kg
<b>B</b>	kg	N
<b>C</b>	N	kg
<b>D</b>	N	N

- 5 A cup contains hot liquid.

Some of the liquid evaporates.

What happens to the mass and to the weight of the liquid in the cup?

	mass	weight
<b>A</b>	decreases	decreases
<b>B</b>	decreases	stays the same
<b>C</b>	stays the same	decreases
<b>D</b>	stays the same	stays the same

- 6 A student is given four different objects and a metre rule. Each object has a known mass. She is asked to determine the densities of the materials from which the four objects are made.

The objects are a copper cylinder, a glass cube, a steel spanner and a stone tile.



copper

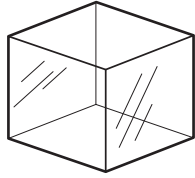

glass

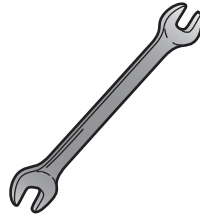

steel

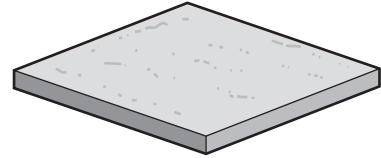

stone

Using only the metre rule, she is able to find the densities of only three of the four materials.

Which three materials are these?

- A** copper, glass and steel  
**B** copper, glass and stone  
**C** copper, steel and stone  
**D** glass, steel and stone
- 7 The diagrams show a steel spring and a graph of its length against the load applied to it.

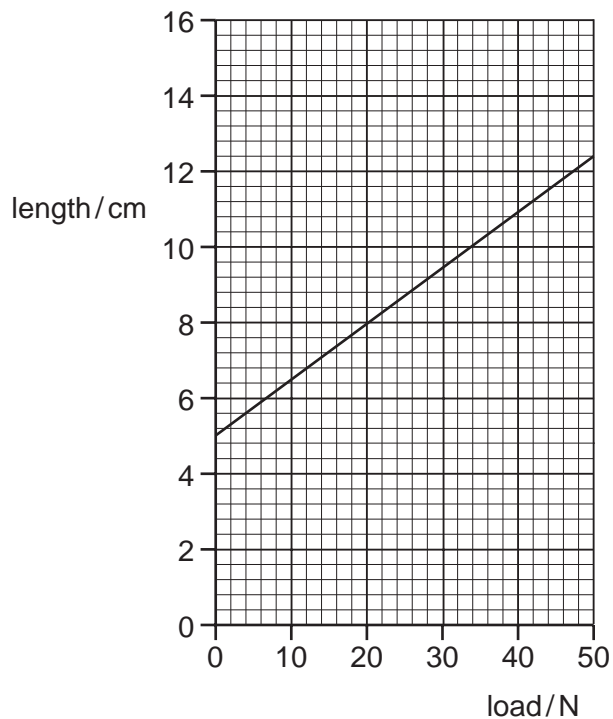
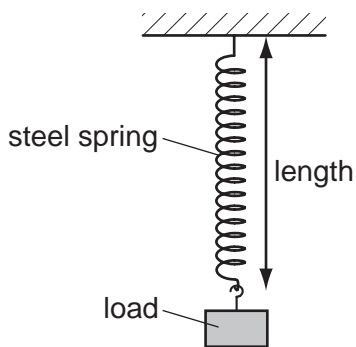

What is the extension of the spring when a load of 20 N is applied to it?

- A** 3.0 cm      **B** 4.5 cm      **C** 5.0 cm      **D** 8.0 cm

- 8 A box is being moved by a fork-lift truck. The total weight of the box is 3000 N.

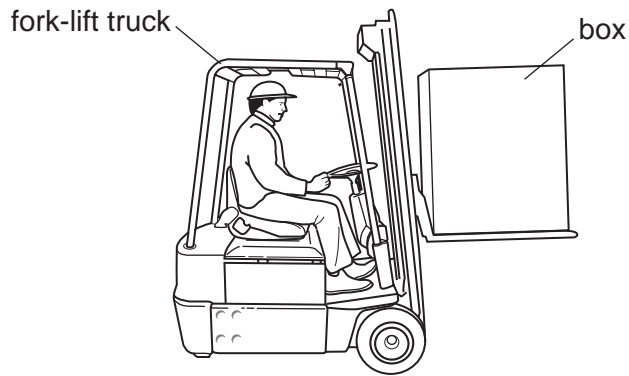

The force exerted by the fork-lift truck on the box is 3500 N upwards.

What is the resultant force on the box?

- A 500 N downwards
  - B 500 N upwards
  - C 6500 N downwards
  - D 6500 N upwards
- 9 An aeroplane is landing. As it descends towards the runway, its speed reduces.

What are the energy changes that take place during the descent?

- A kinetic + gravitational  $\rightarrow$  thermal (heat)
  - B kinetic  $\rightarrow$  gravitational + thermal (heat)
  - C kinetic + thermal (heat)  $\rightarrow$  gravitational
  - D thermal (heat)  $\rightarrow$  kinetic + gravitational
- 10 Energy from uranium is transferred to electrical energy in a nuclear power station.

What is the correct order of the stages of this process?

- A boiler  $\rightarrow$  generator  $\rightarrow$  reactor  $\rightarrow$  turbine
- B generator  $\rightarrow$  boiler  $\rightarrow$  turbine  $\rightarrow$  reactor
- C reactor  $\rightarrow$  boiler  $\rightarrow$  turbine  $\rightarrow$  generator
- D reactor  $\rightarrow$  turbine  $\rightarrow$  boiler  $\rightarrow$  generator

11 It is dangerous for submarines to dive to very great depths.

Why is it dangerous?

- A The density of water is less at greater depths.
- B The pressure of water is greater at greater depths.
- C The temperature of water is higher at greater depths.
- D The weight of the submarine is greater at greater depths.

12 Which block exerts the greatest pressure on the surface below it?

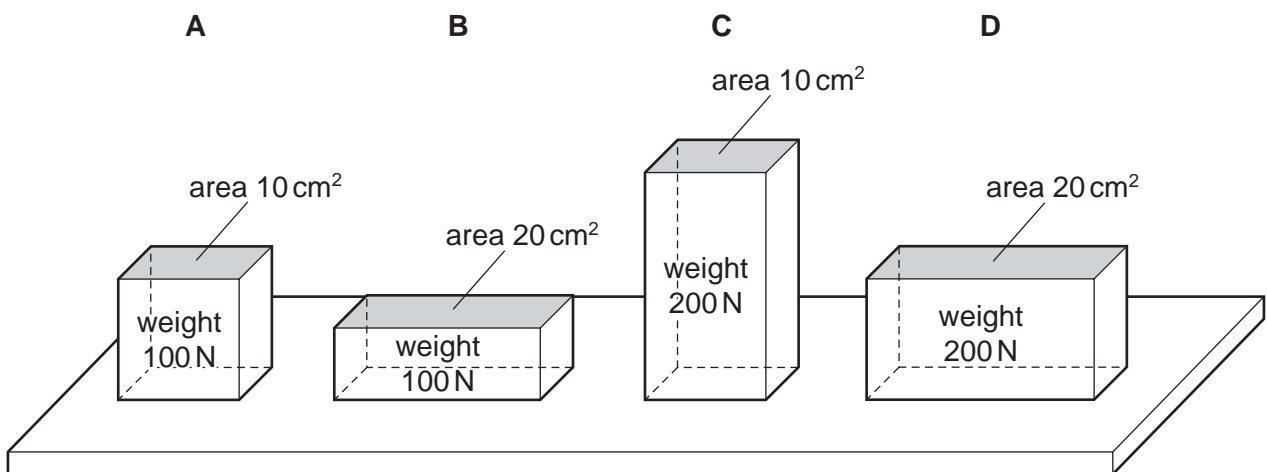

13 A closed flask of gas is placed in a cold-water bath.

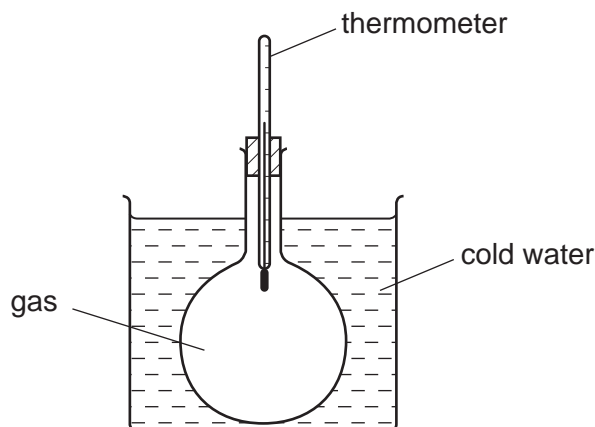

As the flask cools, the temperature of the gas decreases.

What happens to the molecules of the gas?

- A They contract.
- B They expand.
- C They move more quickly.
- D They move more slowly.

- 14 A block of ice cream is prevented from melting by wrapping it in newspaper soaked in water. The water evaporates from the newspaper.

Which molecules escape from the water and what happens to the average speed of the water molecules that remain in the newspaper?

	escaping molecules	average speed of the remaining water molecules
<b>A</b>	the less energetic ones	decreases
<b>B</b>	the less energetic ones	increases
<b>C</b>	the more energetic ones	decreases
<b>D</b>	the more energetic ones	increases

- 15 Equal masses of two different liquids are heated using the same heater. The graph shows how the temperature of each liquid changes with time.

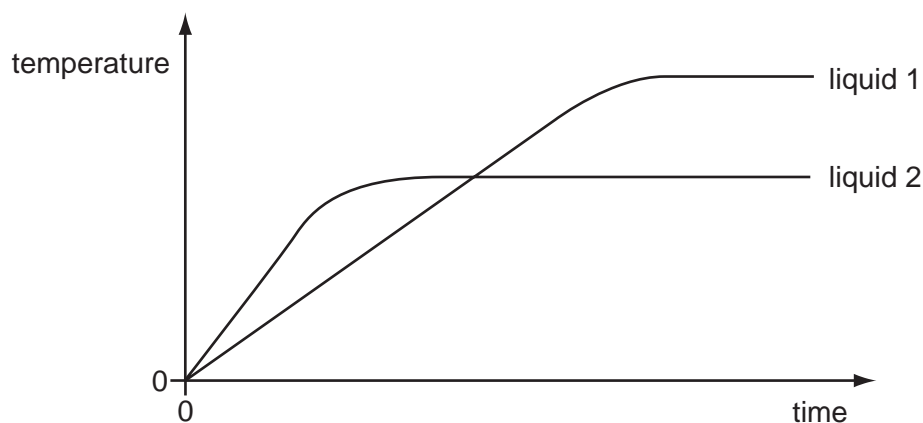

What does the graph tell us about the liquids?

- A** Liquid 1 has a higher melting point than liquid 2.
- B** Liquid 1 has a higher boiling point than liquid 2.
- C** Liquid 1 starts to melt sooner than liquid 2.
- D** Liquid 1 starts to boil sooner than liquid 2.

- 16 A wooden wheel can be strengthened by putting a tight circle of iron around it.

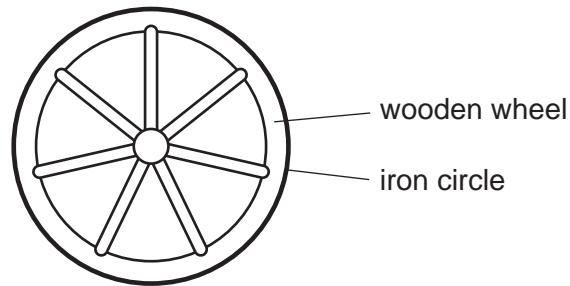

Which action would make it easier to fit the circle over the wood?

- A cooling the iron circle
  - B heating the iron circle
  - C heating the wooden wheel and cooling the iron circle
  - D heating the wooden wheel but not heating or cooling the iron circle
- 17 A piece of hot metal is held by a clamp in a cold room. The air next to the metal becomes hot. The density of the air changes and the air moves.

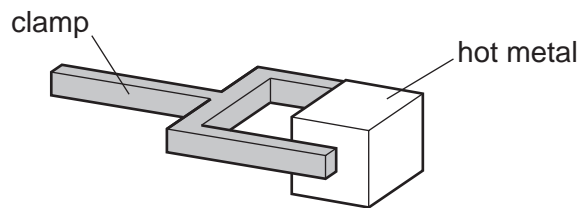

Which row shows the density change of the air and the direction in which the air moves?

	density of air	movement of air
<b>A</b>	decreases	downwards
<b>B</b>	decreases	upwards
<b>C</b>	increases	downwards
<b>D</b>	increases	upwards



- 18 A rod is made half of glass and half of copper. Four pins, **A**, **B**, **C** and **D** are attached to the rod by wax. The rod is heated in the centre as shown.

Which pin falls off first?

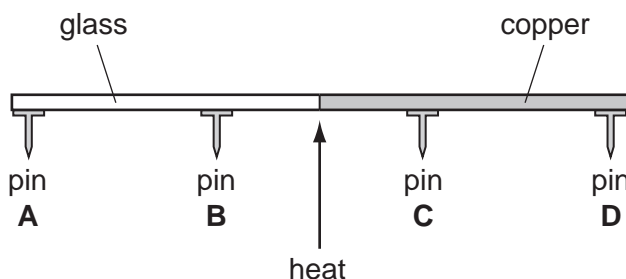

- 19 Which row shows an example of a transverse wave and an example of a longitudinal wave?

	transverse	longitudinal
<b>A</b>	light	radio
<b>B</b>	radio	sound
<b>C</b>	sound	water
<b>D</b>	water	light

- 20 Water waves may be used to demonstrate refraction by making them pass into water of a different depth.

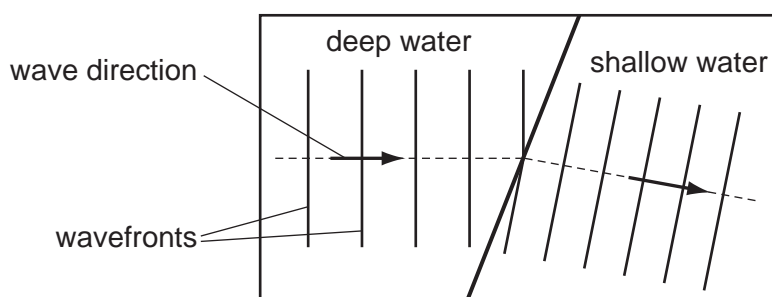

Why does the water wave change direction as it passes into the shallow water?

- A** The frequency of the wave decreases.
- B** The frequency of the wave increases.
- C** The speed of the wave decreases.
- D** The speed of the wave increases.

21 Infra-red waves, microwaves, radio waves and sound waves are all used for communications.

Which waves travel at the same high speed in a vacuum?

- A infra-red waves, microwaves and radio waves
- B infra-red waves, microwaves and sound waves
- C infra-red waves, radio waves and sound waves
- D microwaves, radio waves and sound waves

22 The diagram represents a converging lens forming an image of an object.

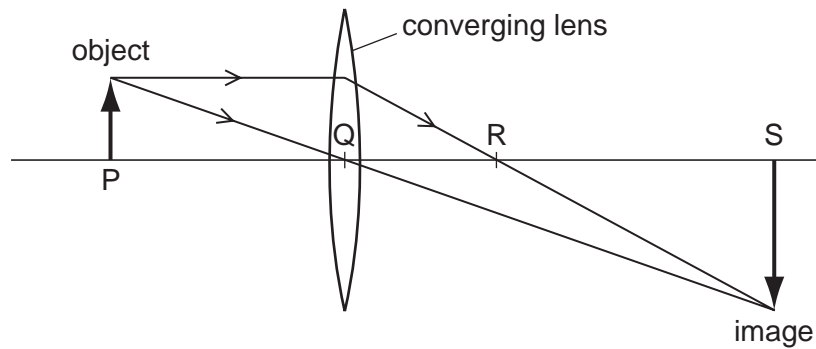

Which distance is the focal length of the lens?

- A PQ
- B PR
- C QR
- D QS

23 A teacher demonstrates the dispersion of white light using a triangular glass prism.

Which diagram shows how this dispersion happens?

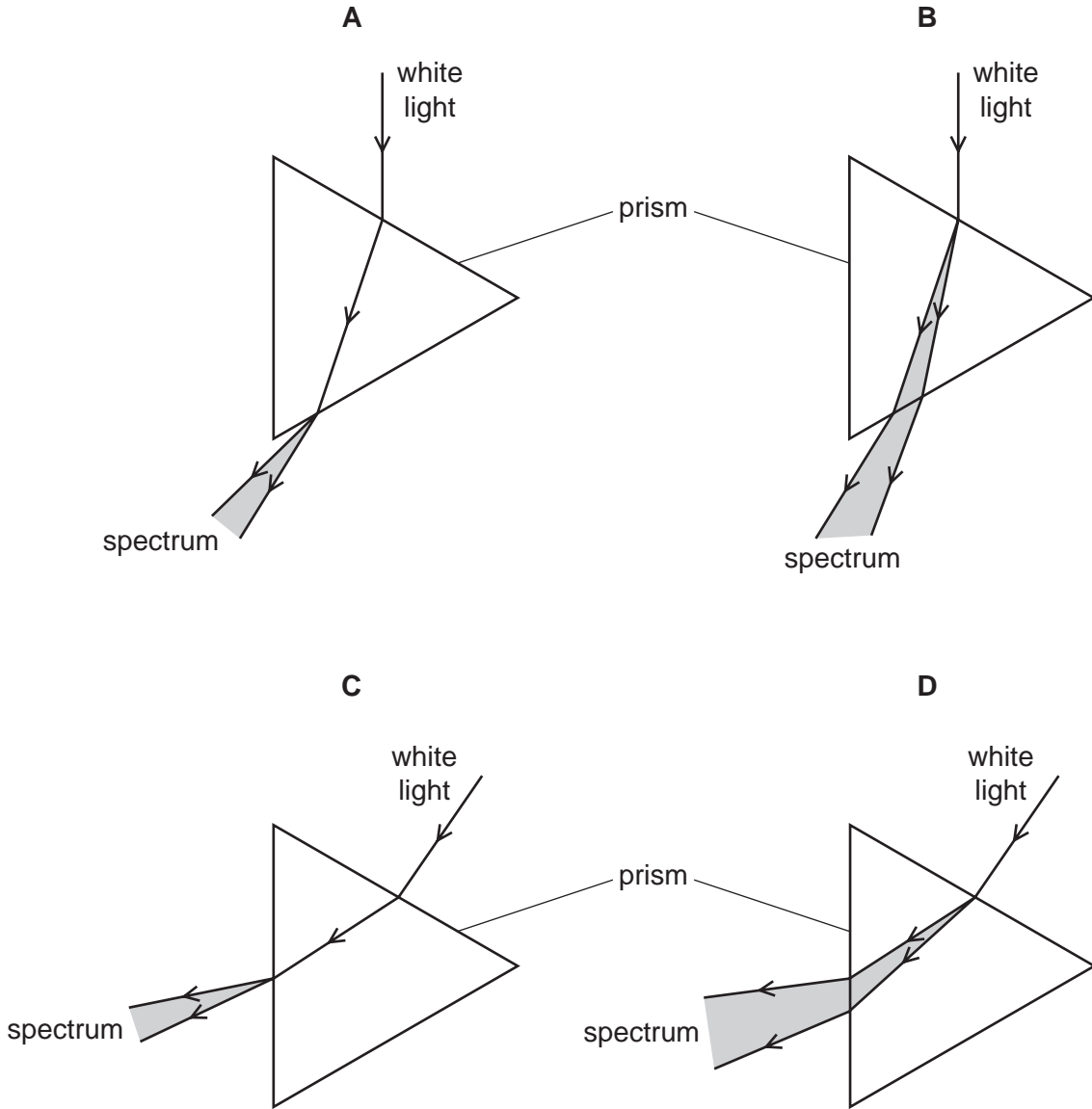

- 24 To estimate the width of a valley, a climber starts a stopwatch as he shouts. He hears an echo from the opposite side of the valley after 1.0 s.

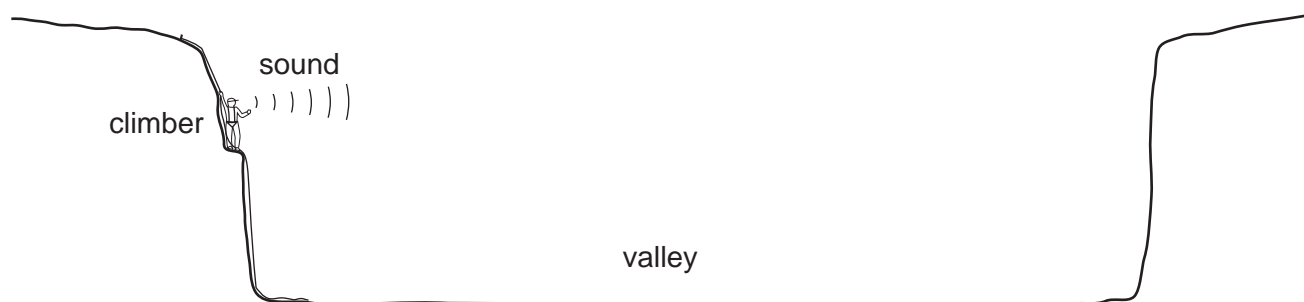

The sound travels at 330 m/s.

What is the width of the valley?

- A 82.5 m      B 165 m      C 330 m      D 660 m
- 25 A police car sounds its siren when travelling to an emergency. The siren produces two different sounds P and Q, which are emitted alternately.

The diagram represents the sound waves emitted by the siren.

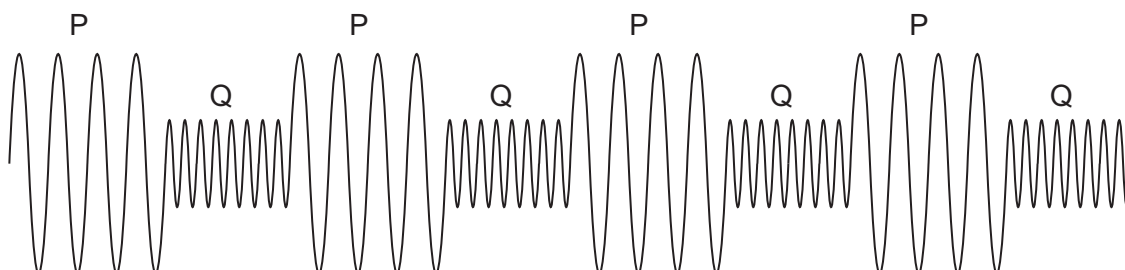

Which of the two sounds P and Q is the louder and which has the higher pitch?

	louder sound	sound of higher pitch
<b>A</b>	P	P
<b>B</b>	P	Q
<b>C</b>	Q	P
<b>D</b>	Q	Q

26 In which pair are both metals ferrous?

- A aluminium and copper
- B aluminium and steel
- C copper and iron
- D iron and steel

27 How can a permanent magnet be demagnetised?

- A cool the magnet for a long time
- B hit the magnet repeatedly with a hammer
- C leave the magnet in a coil which is connected to a battery
- D shine bright light onto the magnet

28 A negatively charged plastic rod P is placed above a positively charged plastic rod Q.

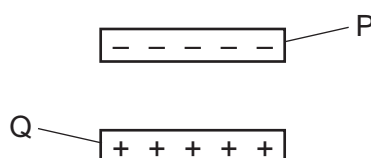

What are the directions of the electrostatic forces on rod P and on rod Q?

	electrostatic force on rod P	electrostatic force on rod Q
<b>A</b>	downwards	downwards
<b>B</b>	downwards	upwards
<b>C</b>	upwards	downwards
<b>D</b>	upwards	upwards

- 29 A student wishes to measure first the electromotive force (e.m.f.) of a battery, and then the potential difference (p.d.) across a resistor.

She has the resistor, the battery and some connecting wires.

What else does she need?

- A a force meter (newton meter) and a voltmeter  
 B an ammeter and a voltmeter  
 C an ammeter only  
 D a voltmeter only
- 30 Two similar balloons hang side by side, on insulating threads, a short distance apart. They are both rubbed with the same dry cloth and become charged.

Which diagram shows how the balloons hang after charging?

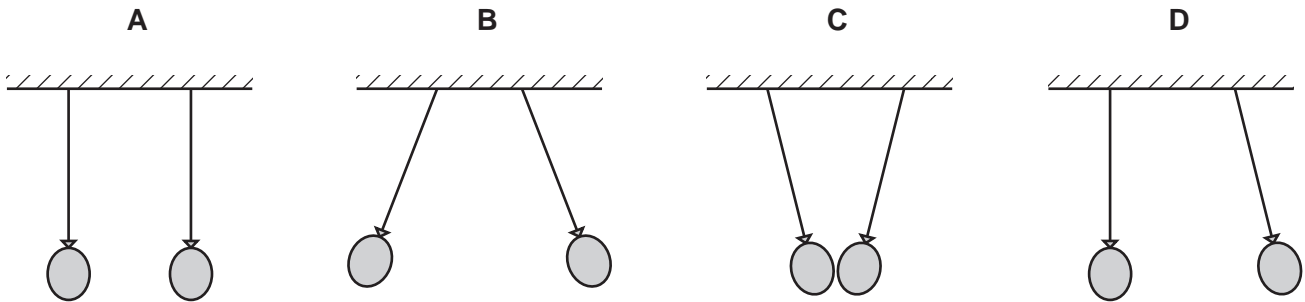

- 31 The diagram shows an electrical component.



What is it?

- A a capacitor  
 B a light-dependent resistor  
 C a thermistor  
 D a variable resistor

32 The diagram shows a circuit.

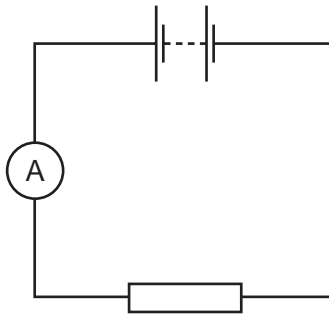

What should be increased to increase the current in the circuit?

- A the e.m.f. of the battery
- B the length of the connecting wires
- C the resistance of the resistor
- D the temperature of the resistor

33 The circuit shown contains a relay. Both lamps are initially off.

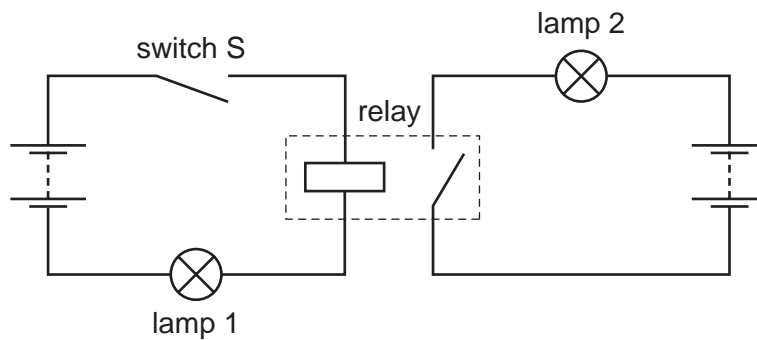

When switch S is closed, the relay operates. What is the state of the lamps?

	lamp 1	lamp 2
<b>A</b>	on	on
<b>B</b>	on	off
<b>C</b>	off	on
<b>D</b>	off	off

- 34 An electric motor is connected to the mains supply by insulated wires. The circuit is protected by a fuse, but the connecting wires become hot.

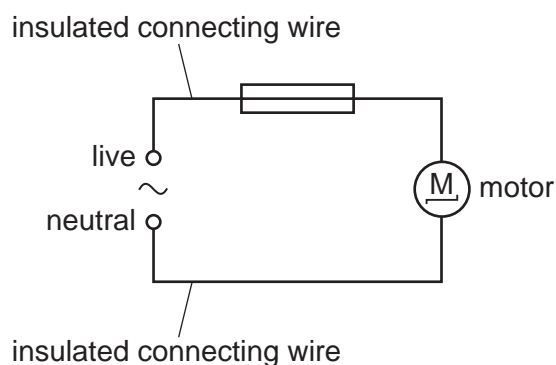

How could the wires be prevented from becoming so hot?

- A Connect a second fuse in the neutral wire.
  - B Use a fuse with a higher current rating.
  - C Use thicker connecting wires.
  - D Use thicker insulation on the connecting wires.
- 35 The diagram shows a transformer.

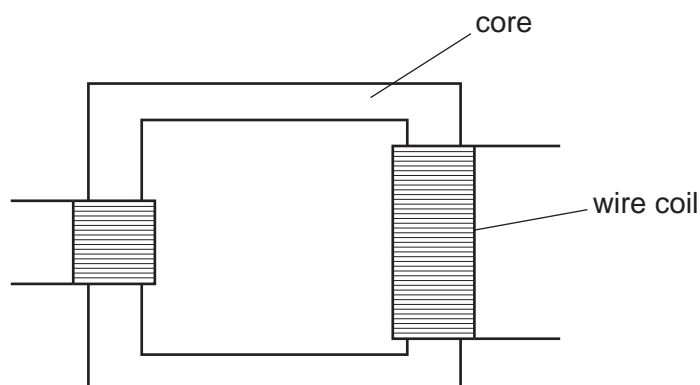

Which materials are suitable to use in its construction?

	core	wire coil
<b>A</b>	copper	iron
<b>B</b>	iron	copper
<b>C</b>	steel	copper
<b>D</b>	steel	iron



36 The direction of the current flowing in a straight wire X is into the paper.

Which diagram shows the shape of the magnetic field pattern around the wire?

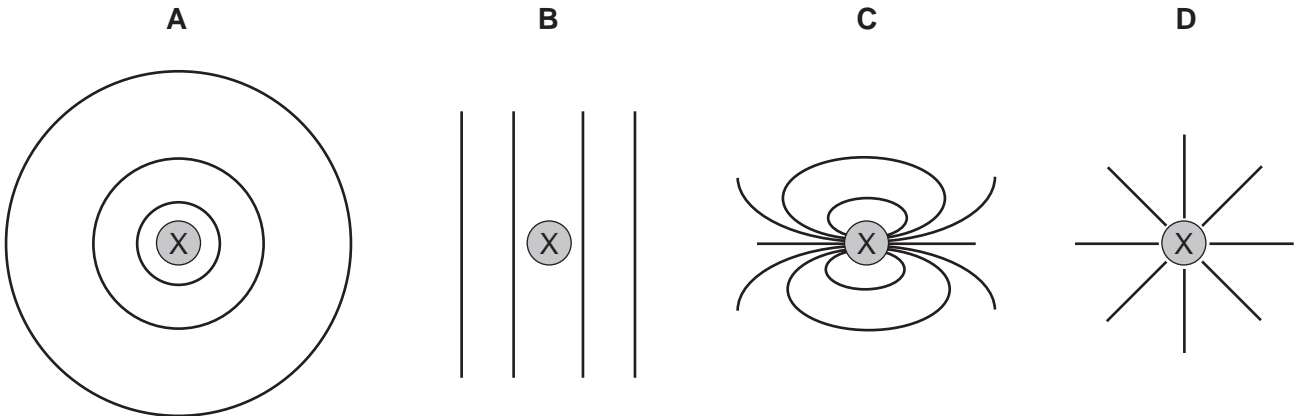

37 A metal rod PQ rests on two horizontal metal wires that are attached to a battery. The rod lies between the poles of a magnet.

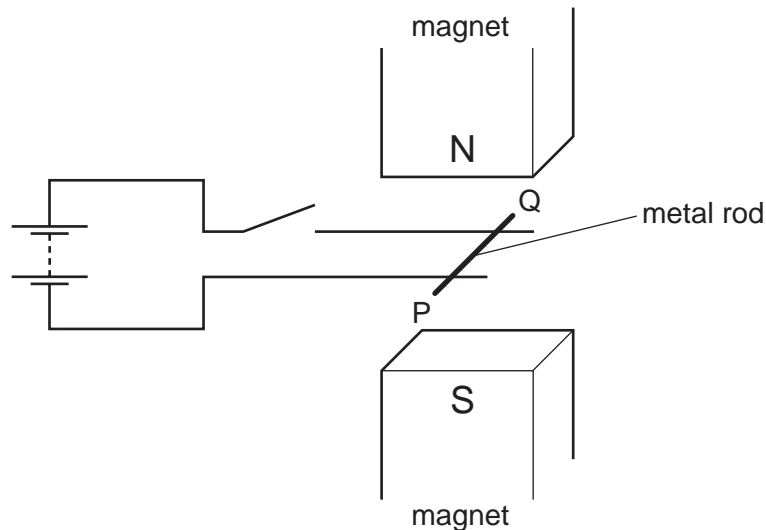

When the switch is closed, the rod moves to the right.

What could be changed so that the rod moves to the left?

- A Open the switch.
- B Reverse the battery terminals and exchange the poles of the magnet.
- C Reverse the battery terminals but without exchanging the poles of the magnet.
- D Turn the metal rod around (P and Q exchanged).

- 38 The diagram shows the screen of a cathode-ray tube. Cathode rays produced behind the screen strike the screen at P. On their way to the screen, the cathode rays pass between two parallel metal plates.

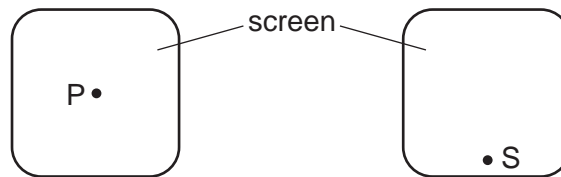

Which arrangement of the metal plates will cause the beam to be deflected and strike the screen at S?

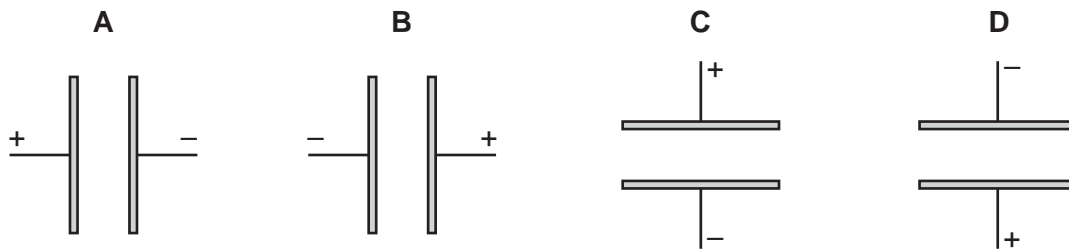

- 39 Why are some radioactive sources stored in boxes made from lead?
- A Lead absorbs emissions from the radioactive sources.
  - B Lead decreases the half-life of radioactive sources.
  - C Lead increases the half-life of radioactive sources.
  - D Lead repels emissions from the radioactive sources.

40 A nucleus of helium has the symbol  ${}^3_2\text{He}$ .

Which diagram represents an atom of  ${}^3_2\text{He}$ ?

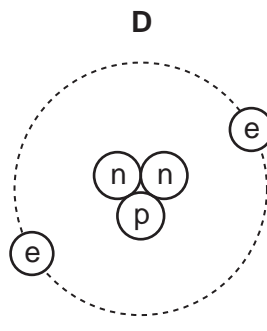
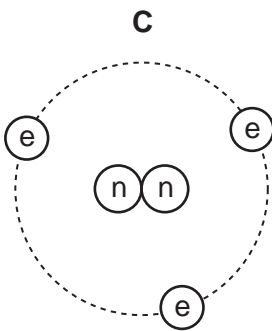
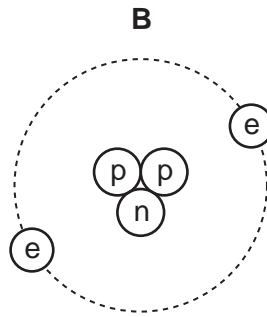
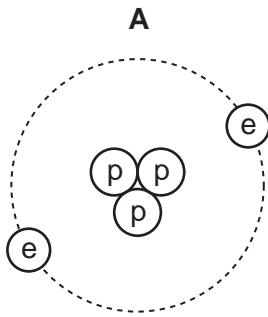

key

(p) = proton

(n) = neutron

(e) = electron

**BLANK PAGE**

---

Permission to reproduce items where third-party owned material protected by copyright is included has been sought and cleared where possible. Every reasonable effort has been made by the publisher (UCLES) to trace copyright holders, but if any items requiring clearance have unwittingly been included, the publisher will be pleased to make amends at the earliest possible opportunity.

Cambridge International Examinations is part of the Cambridge Assessment Group. Cambridge Assessment is the brand name of University of Cambridge Local Examinations Syndicate (UCLES), which is itself a department of the University of Cambridge.