



Cambridge International Examinations
Cambridge International General Certificate of Secondary Education

CHEMISTRY

0620/12

Paper 1 Multiple Choice

October/November 2015

45 Minutes

Additional Materials: Multiple Choice Answer Sheet
 Soft clean eraser
 Soft pencil (type B or HB is recommended)

* 1 0 0 6 7 6 9 2 9 0 *

READ THESE INSTRUCTIONS FIRST

Write in soft pencil.
Do not use staples, paper clips, glue or correction fluid.
Write your name, Centre number and candidate number on the Answer Sheet in the spaces provided unless this has been done for you.
DO NOT WRITE IN ANY BARCODES.

There are **forty** questions on this paper. Answer **all** questions. For each question there are four possible answers **A, B, C** and **D**.
Choose the **one** you consider correct and record your choice in **soft pencil** on the separate Answer Sheet.

Read the instructions on the Answer Sheet very carefully.

Each correct answer will score one mark. A mark will not be deducted for a wrong answer.
Any rough working should be done in this booklet.
A copy of the Periodic Table is printed on page 16.
Electronic calculators may be used.

bestexamhelp.com

The syllabus is approved for use in England, Wales and Northern Ireland as a Cambridge International Level 1/Level 2 Certificate.

This document consists of **15** printed pages and **1** blank page.

1 Which change of state takes place during evaporation?

- A gas to liquid
- B liquid to gas
- C liquid to solid
- D solid to gas

2 The diagram shows apparatus being used to demonstrate how the rate of a chemical reaction changes with temperature.

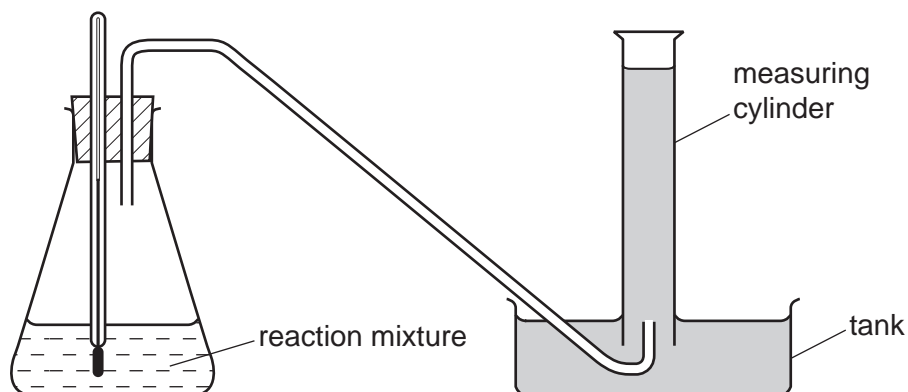

Which statement must be correct?

- A The reaction is endothermic.
- B The reaction is exothermic.
- C The reaction produces a gas.
- D The reaction produces an acid.

- 3 The table shows the nucleon number and the number of neutrons in one atom of isotopes W, X, Y and Z.

isotope	nucleon number	number of neutrons
W	35	18
X	37	20
Y	39	20
Z	40	22

Which statement about W, X, Y and Z is correct?

- A** W and X are isotopes of the same element.
- B** X and Y are isotopes of elements in the same group of the Periodic Table.
- C** Y and Z are isotopes of elements in the same period of the Periodic Table.
- D** Z has a higher proton number than Y.
- 4 Compound X melts at 801 °C and is a good electrical conductor when dissolved in water.
- Compound Y boils at 77 °C, is insoluble in water and is a non-conductor of electricity.

Which type of bonding is present in X and in Y?

	X	Y
A	covalent	covalent
B	covalent	ionic
C	ionic	covalent
D	ionic	ionic

- 5 What do the nuclei of ${}^1_1\text{H}$ hydrogen atoms contain?
- A** electrons and neutrons
- B** electrons and protons
- C** neutrons only
- D** protons only

- 6 The electronic structures of atoms X and Y are shown.

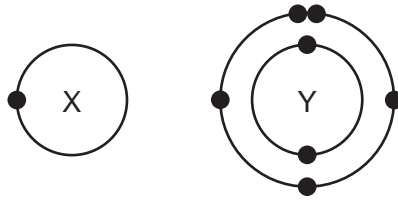

X and Y form a covalent compound.

What is its formula?

- A** XY_5 **B** XY_3 **C** XY **D** X_3Y
- 7 The relative atomic mass of chlorine is 35.5.
- When calculating relative atomic mass, which particle is the mass of a chlorine atom compared to?
- A** a neutron
B a proton
C an atom of carbon-12
D an atom of hydrogen-1
- 8 The diagram shows the electrolysis of concentrated hydrochloric acid and concentrated aqueous sodium chloride using carbon electrodes.

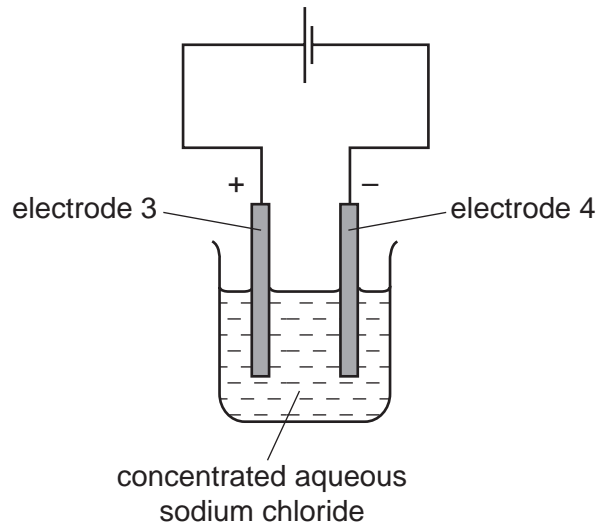
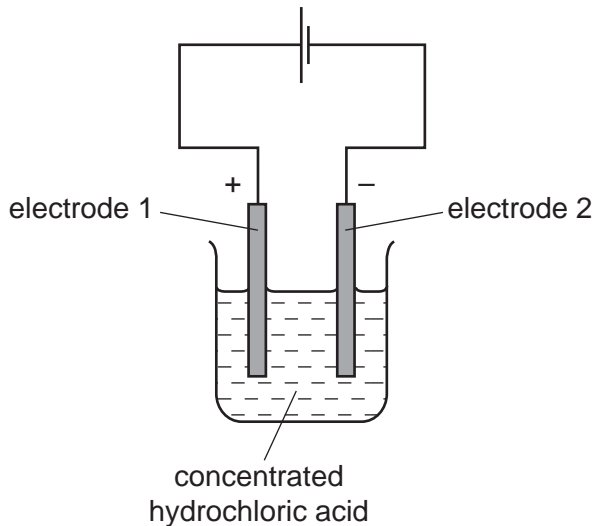

At which electrode(s) is hydrogen produced?

- A** electrode 1 only
B electrodes 1 and 3
C electrode 2 only
D electrodes 2 and 4

9 The diagram shows a section of an overhead power cable.

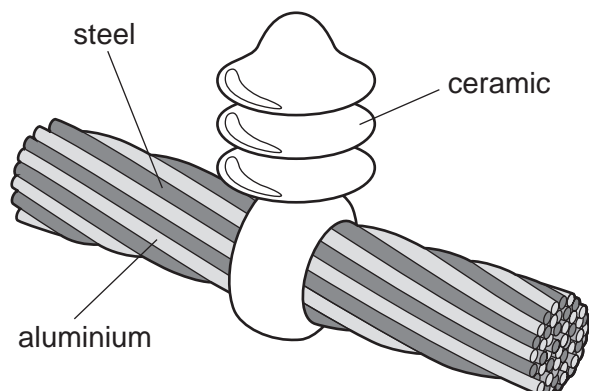

Which statement explains why a particular substance is used?

- A Aluminium has a low density and is a good conductor of electricity.
- B Ceramic is a good conductor of electricity.
- C Steel can rust in damp air.
- D Steel is more dense than aluminium.

10 Hydrogen can be used as a fuel.

Which properties of hydrogen would be advantages and which would be disadvantages?

- 1 Hydrogen is expensive to produce.
- 2 Hydrogen reacts exothermically with oxygen.
- 3 When hydrogen burns, a greenhouse gas is not formed.

	advantages	disadvantages
A	1	2 and 3
B	1 and 2	3
C	1 and 3	2
D	2 and 3	1

11 Which row correctly describes whether the reaction is exothermic or endothermic?

	reaction	exothermic	endothermic
A	calcium carbonate \rightarrow calcium oxide + carbon dioxide	✓	✗
B	carbon + oxygen \rightarrow carbon dioxide	✓	✗
C	methane + oxygen \rightarrow carbon dioxide + water	✗	✓
D	sodium + water \rightarrow sodium hydroxide + hydrogen	✗	✓

- 12 The diagram shows four experiments in which equal volumes of aqueous acid (all in an excess) are added to equal masses of metal. Both acids have the same concentration.

In which experiment has the metal completely reacted in the shortest time?

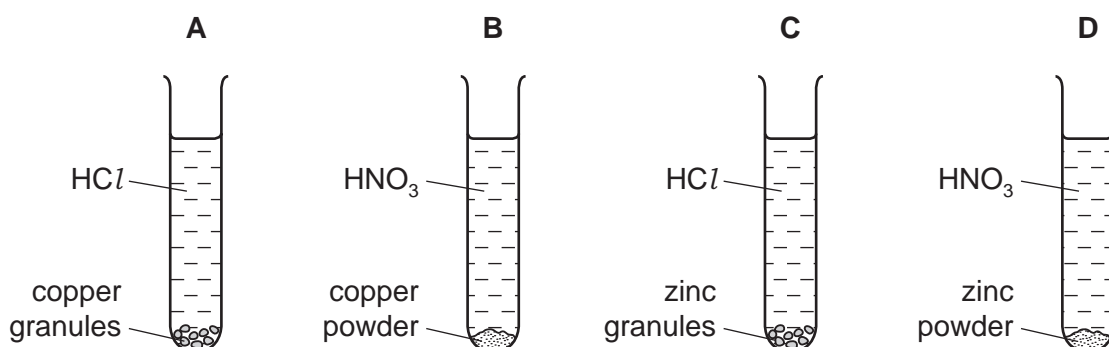

- 13 The element vanadium, V, forms several oxides.

In which change is oxidation taking place?

- A $\text{VO}_2 \rightarrow \text{V}_2\text{O}_3$
 B $\text{V}_2\text{O}_5 \rightarrow \text{VO}_2$
 C $\text{V}_2\text{O}_3 \rightarrow \text{VO}$
 D $\text{V}_2\text{O}_3 \rightarrow \text{V}_2\text{O}_5$

- 14 Which reaction is **not** a reversible reaction?

- A combustion of alkanes
 B hydration of anhydrous copper(II) sulfate
 C melting lead(II) bromide
 D thermal decomposition of hydrated cobalt(II) chloride

- 15 The reaction between magnesium and carbon dioxide is represented by the following equation.

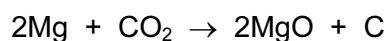

Which statement describes what happens in this reaction?

- A Carbon is oxidised.
 B Magnesium is reduced.
 C Neither oxidation nor reduction happens.
 D The carbon in carbon dioxide is reduced.

19 A salt is produced in each of the following reactions.

- P magnesium + dilute hydrochloric acid
- Q zinc oxide + dilute sulfuric acid
- R sodium hydroxide + dilute hydrochloric acid
- S copper carbonate + dilute sulfuric acid

Which statements about the products of the reactions are correct?

- 1 A flammable gas is produced in reaction P.
- 2 Water is formed in all reactions.
- 3 All the salts formed are soluble in water.

A 1, 2 and 3 **B** 1 and 2 only **C** 1 and 3 only **D** 2 and 3 only

20 The table shows the symbols of three metals with names that begin with the letter C.

Which row correctly shows the melting point of the metals?

	Co	Cr	Cs
A	high	high	high
B	high	high	low
C	low	low	high
D	low	low	low

21 The table gives information about four elements.

Which element is a transition metal?

	electrical conductivity	density in g/cm^3	melting point in $^{\circ}\text{C}$
A	good	0.97	98
B	good	7.86	1535
C	poor	2.33	1410
D	poor	3.12	-7

25 Which substances do **not** react together?

- A calcium + water
- B copper + dilute hydrochloric acid
- C sodium + water
- D zinc + dilute hydrochloric acid

26 Iron is extracted from hematite in a blast furnace.

Which reaction increases the temperature in the blast furnace to over 1500 °C?

- A calcium carbonate → calcium oxide + carbon dioxide
- B calcium oxide + silicon dioxide → calcium silicate
- C carbon + oxygen → carbon dioxide
- D carbon dioxide + carbon → carbon monoxide

27 Which statements about water are correct?

- 1 Household water may contain salts in solution.
- 2 Water for household use is filtered to remove soluble impurities.
- 3 Water is treated with chlorine to kill bacteria.
- 4 Water is used in industry for cooling.

- A 1, 2, 3 and 4
- B 1, 2 and 3 only
- C 1, 3 and 4 only
- D 2, 3 and 4 only

28 Which gas is a pollutant of the air?

- A argon
- B carbon dioxide
- C nitrogen
- D sulfur dioxide

29 Carbon monoxide is an air pollutant produced when petrol is burned in a car engine.

Why is carbon monoxide considered to be an air pollutant?

- A It causes climate change.
- B It causes the corrosion of buildings.
- C It is a significant greenhouse gas.
- D It is poisonous.

30 Metals are welded by using the heat produced by burning a gas in oxygen.

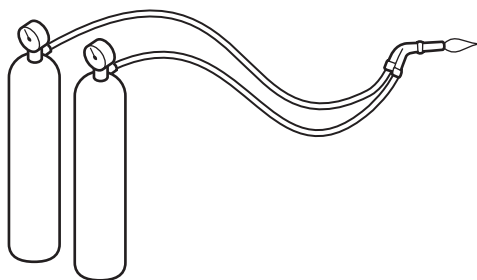

Which gas could **not** be used for this purpose?

- A ethene
 - B hydrogen
 - C helium
 - D methane
- 31 Which elements are present in NPK fertilisers?
- A nitrogen, phosphorus, potassium
 - B nitrogen, potassium, calcium
 - C sodium, phosphorus, potassium
 - D sodium, potassium, calcium

32 The apparatus shown is set up and left for a week.

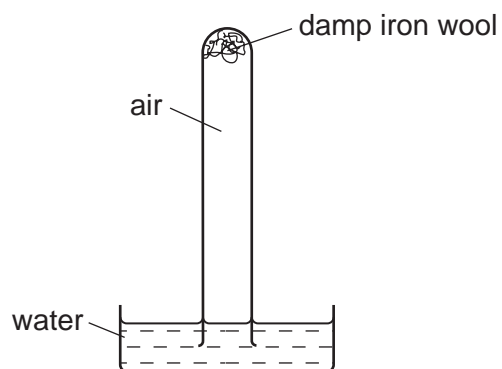

Which diagram shows the level of the water at the end of the week?

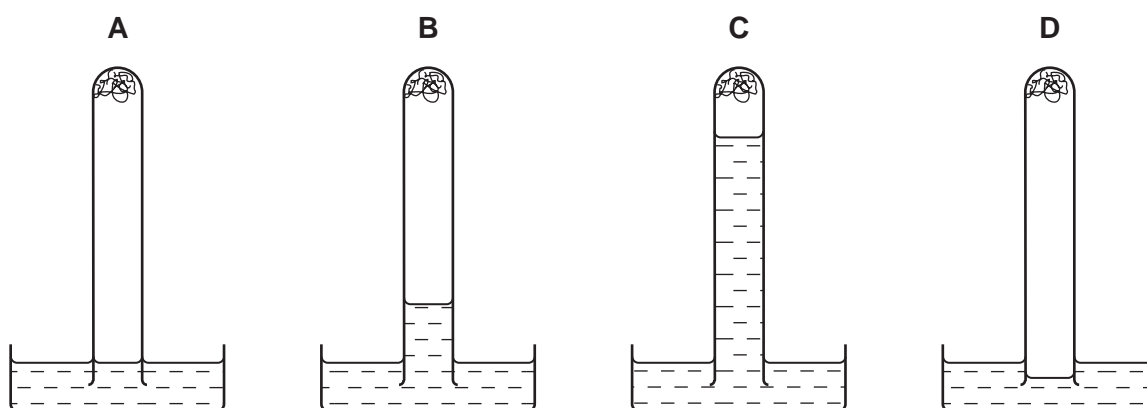

33 A farmer moves his cows into a concrete shelter for protection.

There is little access for fresh air once the door is closed.

Which gases would increase in amount in the shelter?

- A carbon dioxide and carbon monoxide
- B carbon dioxide and methane
- C carbon monoxide and oxygen
- D methane and oxygen

34 A student is asked to draw a diagram showing the uses of limestone.

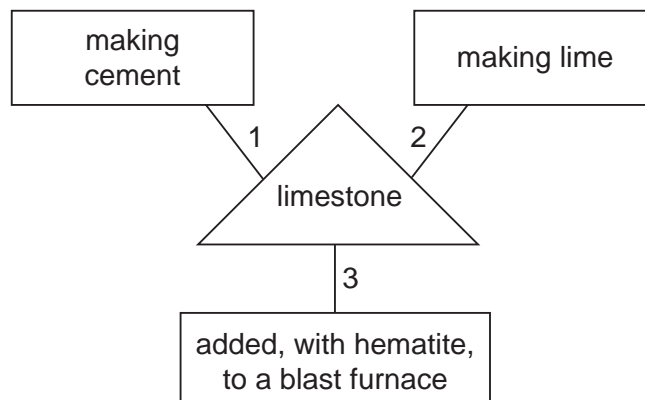

Which numbered lines show a correct use of limestone?

- A 1, 2 and 3
- B 1 and 2 only
- C 1 and 3 only
- D 2 and 3 only

35 Which formula is that of an alkene?

- A C_2H_6
- B C_3H_6
- C C_3H_8
- D C_4H_{10}

36 Which row describes the formation of a polymer?

	monomer	polymer
A	ethane	poly(ethane)
B	ethane	poly(ethene)
C	ethene	poly(ethane)
D	ethene	poly(ethene)

37 Hydrocarbons obtained by fractional distillation of petroleum can be cracked to make useful products.

Which substance could **not** be obtained by cracking propane, $M_r 44$?

- A C_2H_4
- B C_3H_6
- C C_4H_8
- D H_2

38 Ethanol can be formed by

- 1 fermentation
- 2 reaction between steam and ethene

Which of these processes uses a catalyst?

	1	2
A	✓	✓
B	✓	x
C	x	✓
D	x	x

39 The flow chart shows the preparation of ethanol and some important chemistry of ethanol.

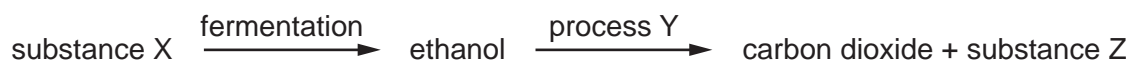

What are X, Y and Z?

	X	Y	Z
A	ethane	combustion	yeast
B	glucose	combustion	steam
C	water	polymerisation	water
D	yeast	fermentation	glucose

40 What are the properties of a dilute solution of ethanoic acid?

	smell	appearance
A	odourless	colourless
B	odourless	red
C	pungent smell	colourless
D	pungent smell	red

DATA SHEET
The Periodic Table of the Elements

		Group												
		I	II	III	IV	V	VI	VII	VIII	IX	X			
		1 H Hydrogen 1												
7	9													
Li Lithium 3	Be Beryllium 4													
23	24													
Na Sodium 11	Mg Magnesium 12													
39	40													
K Potassium 19	Ca Calcium 20	45	48	51	52	55	56	59	59	64	65			
		Sc Scandium 21	Ti Titanium 22	V Vanadium 23	Cr Chromium 24	Mn Manganese 25	Fe Iron 26	Co Cobalt 27	Ni Nickel 28	Cu Copper 29	Zn Zinc 30			
85	88	89	91	93	96	101	101	103	106	108	112			
Rb Rubidium 37	Sr Strontium 38	Y Yttrium 39	Zr Zirconium 40	Nb Niobium 41	Mo Molybdenum 42	Ru Ruthenium 44	Rh Rhodium 45	Pd Palladium 46	Ag Silver 47	Cd Cadmium 48				
133	137	139	178	181	184	190	190	192	195	197	201			
Cs Caesium 55	Ba Barium 56	La Lanthanum 57	Hf Hafnium 72	Ta Tantalum 73	W Tungsten 74	Os Osmium 76	Ir Iridium 77	Pt Platinum 78	Au Gold 79	Hg Mercury 80				
	226	227												
Fr Francium 87	Ra Radium 88	Ac Actinium 89												
*58-71 Lanthanoid series †90-103 Actinoid series														
		140	141	144	150	152	157	159	162	165	167	169	173	175
		Ce Cerium 58	Pr Praseodymium 59	Nd Neodymium 60	Pm Promethium 61	Sm Samarium 62	Eu Europium 63	Gd Gadolinium 64	Dy Dysprosium 66	Ho Holmium 67	Er Erbium 68	Tm Thulium 69	Yb Ytterbium 70	Lu Lutetium 71
		232	238	238	238	238	238	238	238	238	238	238	238	238
		Th Thorium 90	Pa Protactinium 91	U Uranium 92	Np Neptunium 93	Pu Plutonium 94	Am Americium 95	Cm Curium 96	Cf Californium 98	Es Einsteinium 99	Fm Fermium 100	Md Mendelevium 101	No Nobelium 102	Lr Lawrencium 103
		204	207	209	210	210	210	210	210	210	210	210	210	210
		Tl Thallium 81	Pb Lead 82	Bi Bismuth 83	Po Polonium 84	At Astatine 85	Rn Radon 86							

Key

a	X
b	

a = relative atomic mass
X = atomic symbol
b = proton (atomic) number

The volume of one mole of any gas is 24 dm³ at room temperature and pressure (r.t.p.).