

**PHYSICS**

**9702/13**

Paper 1 Multiple Choice

**May/June 2019**

**1 hour 15 minutes**

Additional Materials: Multiple Choice Answer Sheet  
Soft clean eraser  
Soft pencil (type B or HB is recommended)

**READ THESE INSTRUCTIONS FIRST**

Write in soft pencil.

Do not use staples, paper clips, glue or correction fluid.

Write your name, centre number and candidate number on the Answer Sheet in the spaces provided unless this has been done for you.

**DO NOT WRITE IN ANY BARCODES.**

There are **forty** questions on this paper. Answer **all** questions. For each question there are four possible answers **A, B, C** and **D**.

Choose the **one** you consider correct and record your choice in **soft pencil** on the separate Answer Sheet.

**Read the instructions on the Answer Sheet very carefully.**

Each correct answer will score one mark. A mark will not be deducted for a wrong answer.

Any working should be done in this booklet.

Electronic calculators may be used.

This document consists of **17** printed pages and **3** blank pages.



**Data**

|                              |  |
|------------------------------|--|
| speed of light in free space | $c = 3.00 \times 10^8 \text{ m s}^{-1}$  |
| permeability of free space   | $\mu_0 = 4\pi \times 10^{-7} \text{ H m}^{-1}$   |
| permittivity of free space   | $\epsilon_0 = 8.85 \times 10^{-12} \text{ F m}^{-1}$<br>$(\frac{1}{4\pi\epsilon_0} = 8.99 \times 10^9 \text{ m F}^{-1})$ |
| elementary charge            | $e = 1.60 \times 10^{-19} \text{ C}$   |
| the Planck constant          | $h = 6.63 \times 10^{-34} \text{ J s}$   |
| unified atomic mass unit     | $1 \text{ u} = 1.66 \times 10^{-27} \text{ kg}$  |
| rest mass of electron        | $m_e = 9.11 \times 10^{-31} \text{ kg}$  |
| rest mass of proton          | $m_p = 1.67 \times 10^{-27} \text{ kg}$  |
| molar gas constant           | $R = 8.31 \text{ J K}^{-1} \text{ mol}^{-1}$   |
| the Avogadro constant        | $N_A = 6.02 \times 10^{23} \text{ mol}^{-1}$   |
| the Boltzmann constant       | $k = 1.38 \times 10^{-23} \text{ J K}^{-1}$  |
| gravitational constant       | $G = 6.67 \times 10^{-11} \text{ N m}^2 \text{ kg}^{-2}$   |
| acceleration of free fall    | $g = 9.81 \text{ m s}^{-2}$  |

**Formulae**

|                                |  |
|--------------------------------|--|
| uniformly accelerated motion   | $s = ut + \frac{1}{2}at^2$<br>$v^2 = u^2 + 2as$                  |
| work done on/by a gas          | $W = p\Delta V$  |
| gravitational potential        | $\phi = -\frac{Gm}{r}$   |
| hydrostatic pressure           | $p = \rho gh$  |
| pressure of an ideal gas       | $p = \frac{1}{3}\frac{Nm}{V}\langle c^2 \rangle$                 |
| simple harmonic motion         | $a = -\omega^2 x$  |
| velocity of particle in s.h.m. | $v = v_0 \cos \omega t$<br>$v = \pm \omega \sqrt{(x_0^2 - x^2)}$ |
| Doppler effect                 | $f_o = \frac{f_s v}{v \pm v_s}$                                  |
| electric potential             | $V = \frac{Q}{4\pi\epsilon_0 r}$                                 |
| capacitors in series           | $1/C = 1/C_1 + 1/C_2 + \dots$                                    |
| capacitors in parallel         | $C = C_1 + C_2 + \dots$  |
| energy of charged capacitor    | $W = \frac{1}{2}QV$  |
| electric current               | $I = Anvq$   |
| resistors in series            | $R = R_1 + R_2 + \dots$  |
| resistors in parallel          | $1/R = 1/R_1 + 1/R_2 + \dots$                                    |
| Hall voltage                   | $V_H = \frac{BI}{ntq}$   |
| alternating current/voltage    | $x = x_0 \sin \omega t$  |
| radioactive decay              | $x = x_0 \exp(-\lambda t)$                                       |
| decay constant                 | $\lambda = \frac{0.693}{t_{\frac{1}{2}}}$                        |

1 Which is an SI base unit?

- A current
- B gram
- C kelvin
- D volt

2 Osmium, a naturally occurring element, has a density of  $23\,000\text{ kg m}^{-3}$ .

What is also a value of the density of osmium?

- A  $2.3 \times 10^4\ \mu\text{g cm}^{-3}$
- B  $2.3 \times 10^4\ \text{g cm}^{-3}$
- C  $2.3\ \text{kg cm}^{-3}$
- D  $2.3 \times 10^{-2}\ \text{kg cm}^{-3}$

3 Two tugs are towing an oil rig as shown.

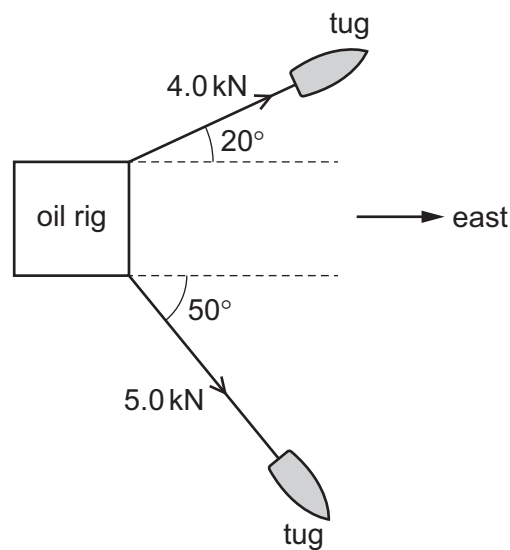

The tensions in the towing cables are 4.0 kN and 5.0 kN.

What is the total force acting on the rig due to the cables, in the direction to the east?

- A 3.1 kN
- B 5.2 kN
- C 7.0 kN
- D 7.3 kN

4 What is the approximate kinetic energy of an Olympic athlete when running at maximum speed during a 100 m race?

- A 400 J
- B 4000 J
- C 40 000 J
- D 400 000 J

- 5 The diagram shows the reading on an analogue ammeter.

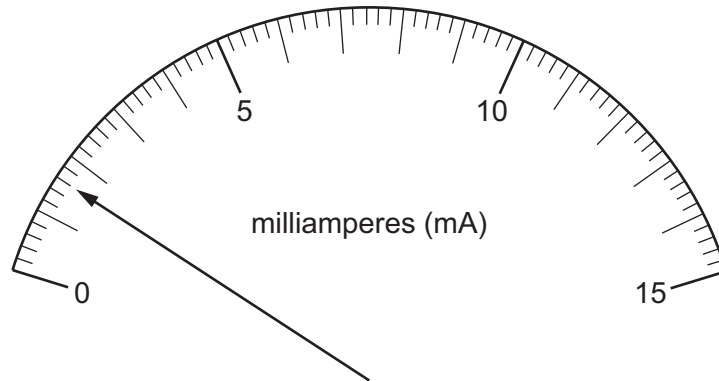

Which digital ammeter reading is the same as the reading on the analogue ammeter?

|          | display units | display reading |
|----------|---------------|-----------------|
| <b>A</b> | $\mu\text{A}$ | 1600            |
| <b>B</b> | $\mu\text{A}$ | 160             |
| <b>C</b> | mA            | 16.0            |
| <b>D</b> | A             | 1.60            |

- 6 A micrometer screw gauge is used to measure the diameter of a small uniform steel sphere. The micrometer reading is  $5.00 \text{ mm} \pm 0.01 \text{ mm}$ .

What will be the percentage uncertainty in a calculation of the volume of the sphere, using these values?

- A** 0.2%      **B** 0.4%      **C** 0.6%      **D** 1.2%

- 7 The graph shows the variation of velocity  $v$  with time  $t$  for an object.

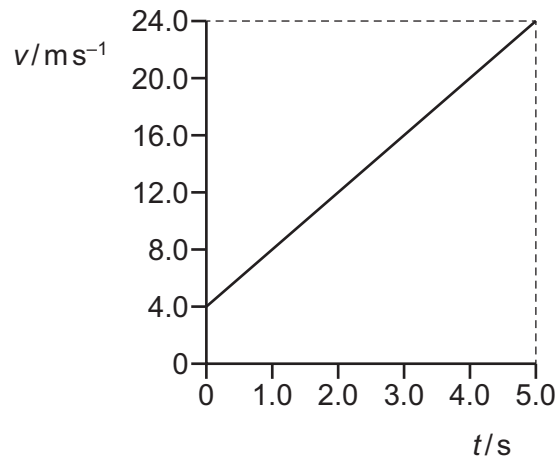

The object passes a fixed point at time  $t = 0$ .

What is the displacement of the object from the fixed point at time  $t = 5.0$  s and what is the acceleration of the object?

|          | displacement<br>/m | acceleration<br>/ms <sup>-2</sup> |
|----------|--------------------|-----------------------------------|
| <b>A</b> | 60                 | 4.0                               |
| <b>B</b> | 70                 | 4.0                               |
| <b>C</b> | 60                 | 4.8                               |
| <b>D</b> | 70                 | 4.8                               |

- 8 A skydiver jumps from an aeroplane and falls vertically through the air.

Which graph shows the variation with time  $t$  of the skydiver's vertical velocity  $v$ ?

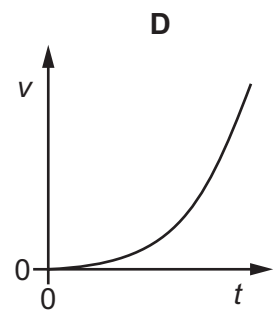
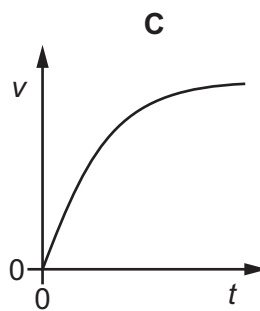
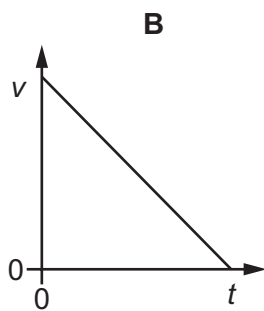
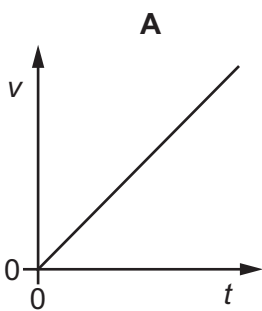

- 9 A nucleus collides with a stationary nucleus in a vacuum. The diagrams show the paths of the nuclei before and after the collision.

No other particles are involved in the collision.

Which diagram is **not** possible?

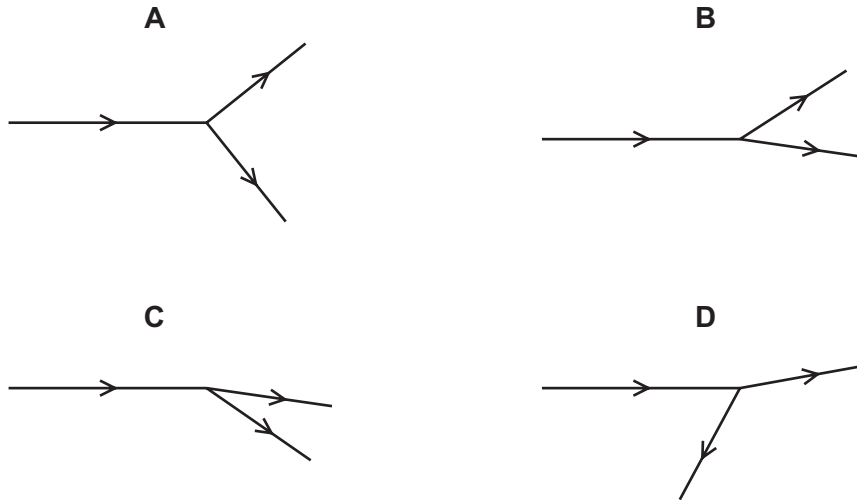

- 10 A uniform electric field is created by two parallel vertical plates. A positively charged particle is in the vacuum between the plates, as shown.

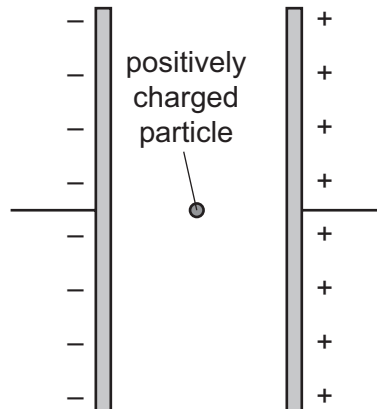

Which statement is correct?

- A The electric field makes the particle move towards the negative plate with a constant speed.
- B The electric field makes the particle move towards the negative plate with a constant acceleration.
- C The electric field produces a uniform rate of decrease in the particle's acceleration.
- D The electric field produces a uniform rate of increase in the particle's acceleration.

- 11 A picture is suspended from a nail by a single cord connected to two points X and Y on the picture. There is negligible friction between the cord and the nail so that the tension in both sides of the cord is the same. The picture hangs symmetrically, as shown.

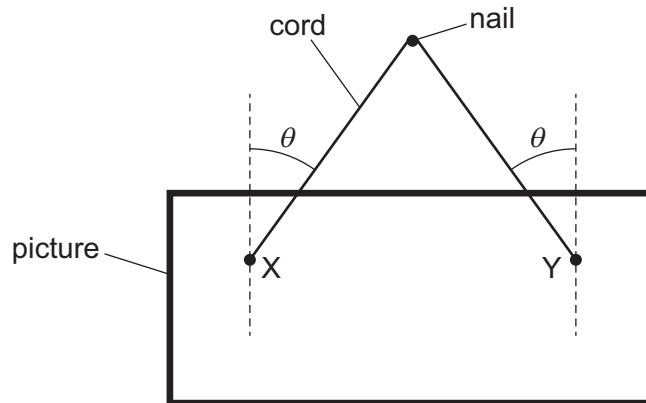

The tension in the cord is  $T$ . The angle between the cord and the vertical is  $\theta$  on both sides.

Which statement is correct?

- A** Increasing the length of the cord, with points X and Y in the same place on the picture, would reduce the tension in the cord.
- B** Moving points X and Y further apart on the picture while keeping the length of the cord constant would reduce the tension in the cord.
- C** Moving points X and Y to the top edge of the picture while keeping their distance apart constant and the length of the cord constant would reduce the tension in the cord.
- D** The weight of the picture is equal to  $T \cos \theta$ .
- 12 A shop sign weighing 75 N hangs from a frame attached to a vertical wall.

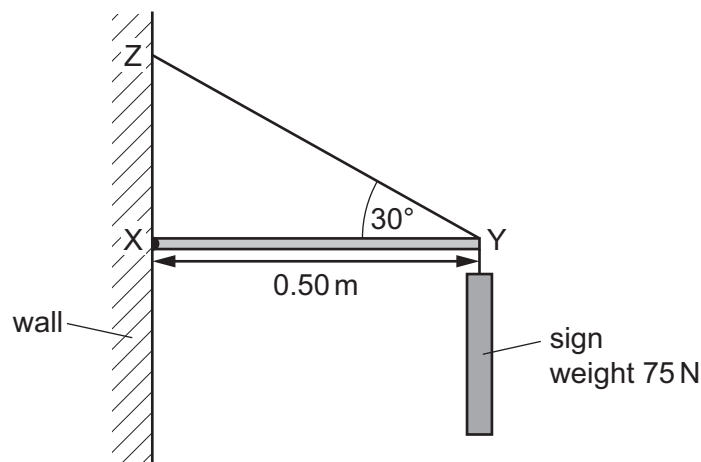

The frame consists of a horizontal rod XY and a rod YZ that is at an angle of  $30^\circ$  to the horizontal. Rod XY is attached to the wall by a hinge at X and has length 0.50 m. Assume that the weights of the rods are negligible.

What is the horizontal force exerted by the wall on rod XY?

- A** 0 N                      **B** 43 N                      **C** 130 N                      **D** 150 N



13 What is the torque of the couple shown?

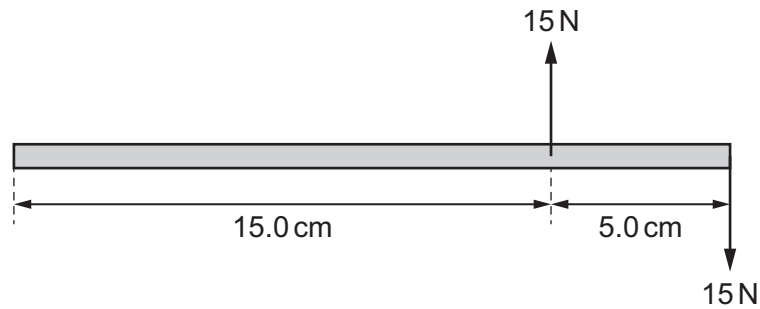

- A** 0.75 Nm      **B** 1.50 Nm      **C** 3.00 Nm      **D** 5.25 Nm

14 Water has a density of  $1.0 \text{ g cm}^{-3}$ .

Glycerine has a density of  $1.3 \text{ g cm}^{-3}$ .

A student measures out a volume of  $40 \text{ cm}^3$  of glycerine into a container.

The student adds water to the container to make a mixture of water and glycerine. Assume that the total volume of water and glycerine does not change when the two liquids are mixed.

Which volume of water needs to be added to make a mixture of density  $1.1 \text{ g cm}^{-3}$ ?

- A**  $4.0 \text{ cm}^3$       **B**  $8.0 \text{ cm}^3$       **C**  $34 \text{ cm}^3$       **D**  $80 \text{ cm}^3$

15 Which statement about the principle of conservation of energy is correct?

- A** Energy conversion helps to conserve energy sources.  
**B** Energy is conserved only in systems with an efficiency of 100%.  
**C** The supply of energy is limited so energy should be conserved.  
**D** The total amount of energy in a closed system is constant.

16 A student can run or walk up the stairs to her classroom.

Which statement describes the power required and the gravitational potential energy gained while running up the stairs compared to walking up them?

- A** Running provides more gravitational potential energy and uses more power.  
**B** Running provides more gravitational potential energy and uses the same power.  
**C** Running provides the same gravitational potential energy and uses more power.  
**D** Running provides the same gravitational potential energy and uses the same power.

- 17 A lead pellet is shot vertically upwards into a clay block that is stationary at the moment of impact but is able to rise freely after impact.

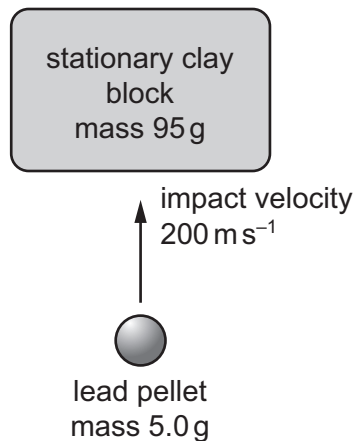

The mass of the pellet is 5.0 g and the mass of the clay block is 95 g.

The pellet hits the block with an initial vertical velocity of 200 m s<sup>-1</sup>. It embeds itself in the block and does not emerge.

How high above its initial position will the block rise?

- A** 5.1 m      **B** 5.6 m      **C** 10 m      **D** 100 m
- 18 On the surface of a planet, 30 J of work is done against gravity to raise a mass of 1.0 kg through a height of 10 m.
- How much work must be done to raise a mass of 4.0 kg through a height of 5.0 m on this planet?
- A** 15 J      **B** 60 J      **C** 120 J      **D** 200 J
- 19 Four solid steel rods, each of length 2.0 m and cross-sectional area 250 mm<sup>2</sup>, equally support an object weighing 10 kN. The weight of the object causes the rods to contract by 0.10 mm. The rods obey Hooke's law.

What is the Young modulus of steel?

- A**  $2.0 \times 10^8 \text{ N m}^{-2}$   
**B**  $2.0 \times 10^{11} \text{ N m}^{-2}$   
**C**  $8.0 \times 10^8 \text{ N m}^{-2}$   
**D**  $8.0 \times 10^{11} \text{ N m}^{-2}$

- 20 A wire is attached at one end to a fixed point. A tensile force  $F$  is applied to the other end of the wire, causing it to extend. This is shown on the graph by the line OSP.

The force  $F$  is then gradually reduced to zero and the wire contracts. This is shown on the graph by the line PQ.

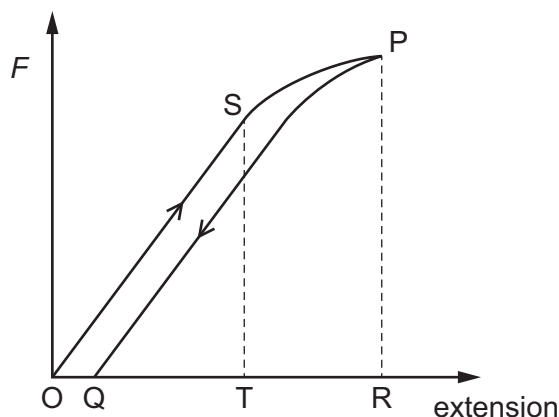

Which area on the graph represents the work done by the wire as it contracts?

- A** OSTO      **B** OSPRO      **C** QPRQ      **D** OSPQO
- 21 The graph shows the variation of displacement  $y$  with distance  $x$  along a progressive wave at one instant in time.

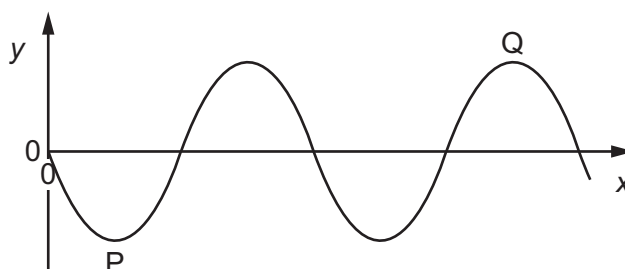

What is the phase difference between points P and Q on the wave?

- A**  $90^\circ$       **B**  $270^\circ$       **C**  $540^\circ$       **D**  $630^\circ$
- 22 Wave-power generators take advantage of the energy that is transferred by the motion of waves across the surface of the oceans. The energy of a wave depends on its amplitude.

What is the correct definition of amplitude?

- A** the average amount of energy possessed by a wave  
**B** the difference in displacement between a peak and a trough  
**C** the maximum displacement of a point on the wave from equilibrium  
**D** the number of oscillations of a wave that occur per second

- 23 A sound wave of frequency 270 Hz is recorded by a cathode-ray oscilloscope (CRO). The waveform on the CRO is shown.

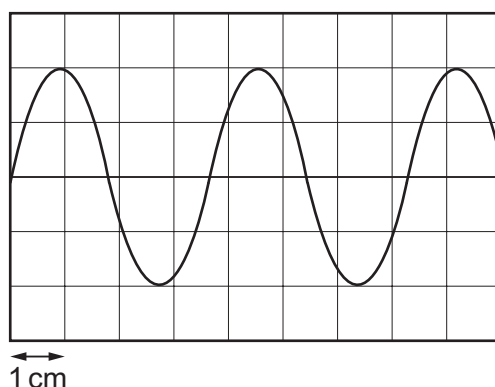

What is the time-base setting on the CRO?

- A 0.1 ms cm<sup>-1</sup>    B 1 ms cm<sup>-1</sup>    C 10 ms cm<sup>-1</sup>    D 100 ms cm<sup>-1</sup>
- 24 A motor boat vibrates in the water so that it produces water waves of frequency 0.20 Hz. The speed of these waves in the water is 20 ms<sup>-1</sup>. The motor boat moves with a speed of 5.0 ms<sup>-1</sup> directly towards a stationary sailing boat.

The Doppler effect equation for sound waves also applies to water waves.

What is the frequency with which the waves hit the stationary sailing boat?

- A 0.15 Hz    B 0.16 Hz    C 0.25 Hz    D 0.27 Hz
- 25 Infrared laser light is used for the transmission of data along optic fibres.
- What is a typical wavelength of infrared radiation?
- A  $5 \times 10^{-5}$  m    B  $5 \times 10^{-7}$  m    C  $2 \times 10^{-9}$  m    D  $2 \times 10^{-11}$  m
- 26 An elastic string is attached to an oscillator at one end and clamped at the other end so that the string is horizontal and in tension.

The oscillator is made to oscillate vertically. The frequency of oscillation is gradually increased from zero until a stationary wave is set up in the string. The frequency is then increased further to frequency  $f$ , when a second stationary wave is set up in the string.

The frequency is then increased further.

At which frequency does a third stationary wave occur?

- A 1.2 $f$     B 1.5 $f$     C 2.0 $f$     D 3.0 $f$

- 27 In an experiment, water waves in a ripple tank are incident on a gap, as shown.

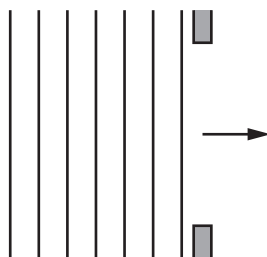

Some diffraction of the water waves is observed.

Which change to the experiment would provide a better demonstration of diffraction?

- A Increase the amplitude of the waves.
  - B Increase the frequency of the waves.
  - C Increase the wavelength of the waves.
  - D Increase the width of the gap.
- 28 Light of wavelength  $\lambda$  is emitted from two point sources R and S and falls onto a distant screen.

R •

S •

screen



(not to scale)

At point P on the screen, the light intensity is zero.

What could explain the zero intensity at P?

- A Light from the two sources is emitted  $180^\circ$  out of phase and the path difference to P is  $\frac{1}{2}\lambda$ .
  - B Light from the two sources is emitted in phase and the path difference to P is  $\lambda$ .
  - C Light from the two sources is emitted  $90^\circ$  out of phase and the path difference to P is  $\lambda$ .
  - D Light from the two sources is emitted in phase and the path difference to P is  $\frac{1}{2}\lambda$ .
- 29 Apparatus is arranged to show double-slit interference using monochromatic light. The slit separation is 0.10 mm. The distance from the double slit to the screen where the interference pattern is observed is 2.4 m and the fringe width is 12 mm.

The distance to the screen is now changed to 1.8 m and the slit separation is doubled.

What is the new fringe width?

- A 1.5 mm
- B 4.5 mm
- C 6.0 mm
- D 9.0 mm

- 30 Monochromatic light of wavelength 690 nm passes through a diffraction grating with 300 lines per mm, producing a series of maxima (bright spots) on a screen.

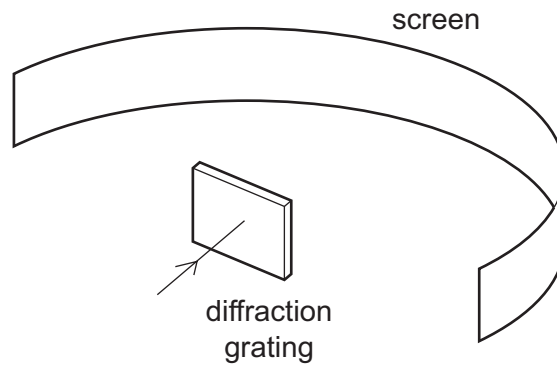

What is the greatest number of maxima that can be observed?

- A 4                      B 5                      C 8                      D 9
- 31 Which diagram represents the electric field line pattern due to a combination of two positive charges?

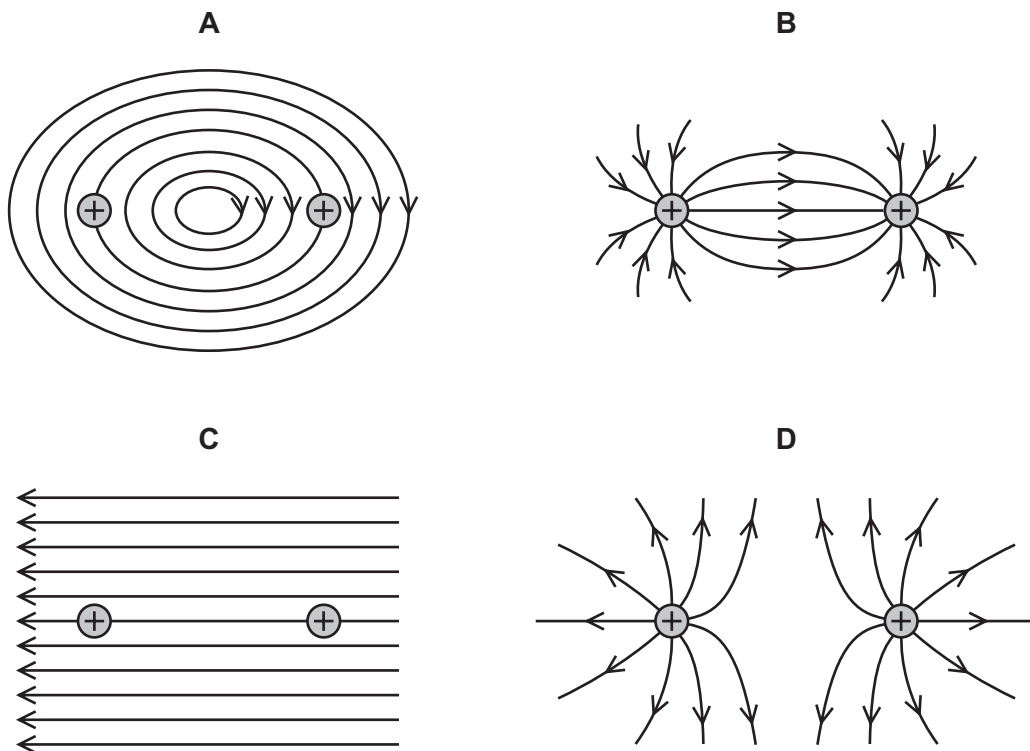

- 32 Which two units are used to define the volt?

- A ampere and ohm  
 B coulomb and joule  
 C coulomb and ohm  
 D coulomb and second

- 33 The graph shows the variation with length of the resistance of a uniform metal wire.

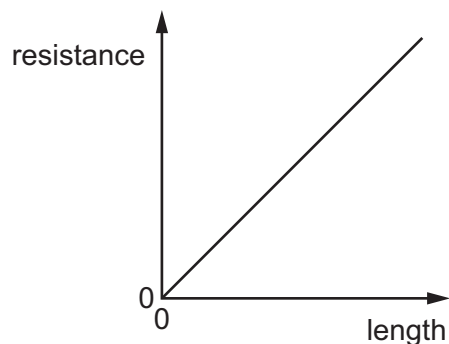

The gradient of the graph is  $G$ .  
The wire has cross-sectional area  $A$ .

Which expression could be used to calculate the resistivity of the metal of the wire?

- A**  $G \times A$       **B**  $\frac{G}{A}$       **C**  $\frac{A}{G}$       **D**  $G \times A^2$

- 34 Diagram 1 shows a lamp connected to a supply through two switches.

During repairs, an electrician mistakenly reverses the connections  $X_1$  and  $Z_1$ , so that  $Z_1$  is connected to the supply and  $X_1$  to the other switch at  $Z_2$ , as shown in diagram 2.

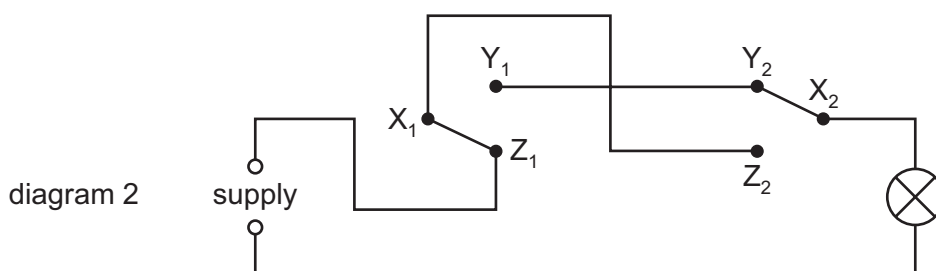
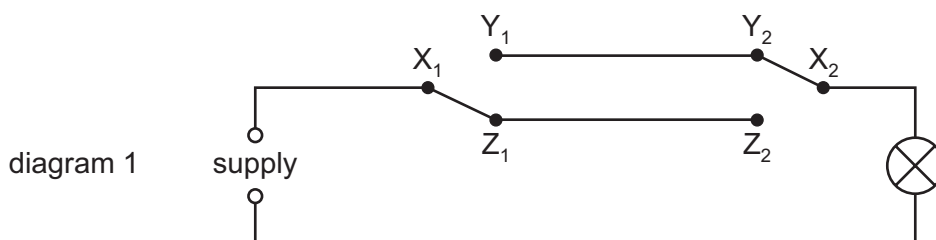

Which switch positions will now light the lamp?

|          |                |                |
|----------|----------------|----------------|
| <b>A</b> | $X_1$ to $Y_1$ | $X_2$ to $Y_2$ |
| <b>B</b> | $X_1$ to $Y_1$ | $X_2$ to $Z_2$ |
| <b>C</b> | $X_1$ to $Z_1$ | $X_2$ to $Y_2$ |
| <b>D</b> | $X_1$ to $Z_1$ | $X_2$ to $Z_2$ |

- 35 A wire supplying a shower heater with a current of 35 A has a resistance of 25 m $\Omega$ .

What is the power dissipated in the wire?

- A 31 W                      B 49 W                      C 31 kW                      D 49 kW

- 36 A student has a set of identical cells and identical lamps. The cells have negligible internal resistance.

A lamp connected to a cell lights with normal brightness.

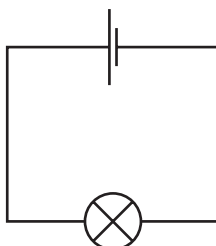

What happens when the student connects the lamps and the cells as shown?

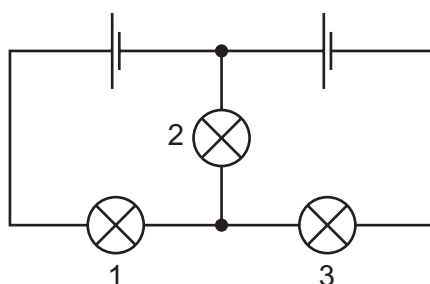

- A All three lamps light with normal brightness.  
 B Only lamp 2 lights with normal brightness.  
 C Only lamps 1 and 3 light with normal brightness.  
 D None of the lamps light with normal brightness.

- 37 A potential divider circuit is shown.

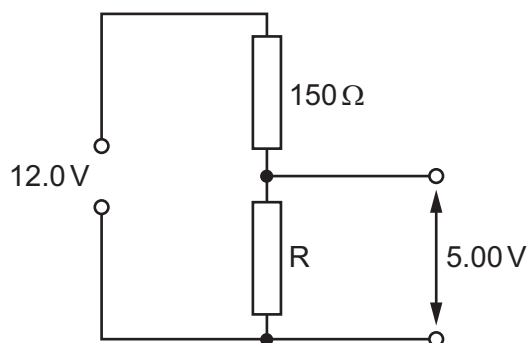

What is the resistance of resistor R in the potential divider circuit?

- A 62.5  $\Omega$                       B 107  $\Omega$                       C 210  $\Omega$                       D 360  $\Omega$



- 38 Two cells of electromotive force (e.m.f.) 3.0V and 1.2V and negligible internal resistance are connected to resistors of resistance  $9.0\Omega$  and  $18\Omega$  as shown.

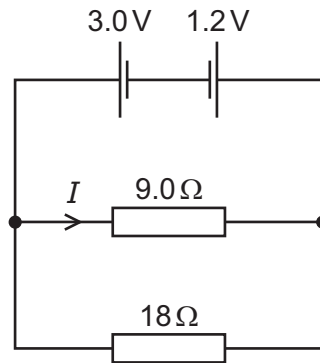

What is the current  $I$  in the  $9.0\Omega$  resistor?

- A 0.10 A      B 0.20 A      C 0.30 A      D 0.47 A
- 39 What is a correct estimate of the order of magnitude of the diameter of a typical atomic nucleus?
- A  $10^{-14}$  m      B  $10^{-18}$  m      C  $10^{-22}$  m      D  $10^{-26}$  m
- 40 Which statement describes  $\beta^-$  decay in terms of a simple quark model?
- A A down quark changes to an up quark, and an electron and an electron antineutrino are emitted.
- B A down quark changes to an up quark, and a positron and an electron neutrino are emitted.
- C An up quark changes to a down quark, and an electron and an electron antineutrino are emitted.
- D An up quark changes to a down quark, and a positron and an electron neutrino are emitted.





**BLANK PAGE**

---

Permission to reproduce items where third-party owned material protected by copyright is included has been sought and cleared where possible. Every reasonable effort has been made by the publisher (UCLES) to trace copyright holders, but if any items requiring clearance have unwittingly been included, the publisher will be pleased to make amends at the earliest possible opportunity.

To avoid the issue of disclosure of answer-related information to candidates, all copyright acknowledgements are reproduced online in the Cambridge Assessment International Education Copyright Acknowledgements Booklet. This is produced for each series of examinations and is freely available to download at [www.cambridgeinternational.org](http://www.cambridgeinternational.org) after the live examination series.

Cambridge Assessment International Education is part of the Cambridge Assessment Group. Cambridge Assessment is the brand name of the University of Cambridge Local Examinations Syndicate (UCLES), which itself is a department of the University of Cambridge.