

CANDIDATE
NAME

CENTRE
NUMBER

--	--	--	--	--

CANDIDATE
NUMBER

--	--	--	--



PHYSICS

9702/23

Paper 2 AS Structured Questions

October/November 2015

1 hour

Candidates answer on the Question Paper.

No Additional Materials are required.

READ THESE INSTRUCTIONS FIRST

Write your Centre number, candidate number and name on all the work you hand in.

Write in dark blue or black pen.

You may use an HB pencil for any diagrams or graphs.

Do not use staples, paper clips, glue or correction fluid.

DO NOT WRITE IN ANY BARCODES.

Answer **all** questions.

Electronic calculators may be used.

You may lose marks if you do not show your working or if you do not use appropriate units.

At the end of the examination, fasten all your work securely together.

The number of marks is given in brackets [] at the end of each question or part question.

This document consists of **16** printed pages.

Data

speed of light in free space,	$c = 3.00 \times 10^8 \text{ m s}^{-1}$
permeability of free space,	$\mu_0 = 4\pi \times 10^{-7} \text{ H m}^{-1}$
permittivity of free space,	$\epsilon_0 = 8.85 \times 10^{-12} \text{ F m}^{-1}$
	$(\frac{1}{4\pi\epsilon_0} = 8.99 \times 10^9 \text{ m F}^{-1})$
elementary charge,	$e = 1.60 \times 10^{-19} \text{ C}$
the Planck constant,	$h = 6.63 \times 10^{-34} \text{ J s}$
unified atomic mass constant,	$u = 1.66 \times 10^{-27} \text{ kg}$
rest mass of electron,	$m_e = 9.11 \times 10^{-31} \text{ kg}$
rest mass of proton,	$m_p = 1.67 \times 10^{-27} \text{ kg}$
molar gas constant,	$R = 8.31 \text{ J K}^{-1} \text{ mol}^{-1}$
the Avogadro constant,	$N_A = 6.02 \times 10^{23} \text{ mol}^{-1}$
the Boltzmann constant,	$k = 1.38 \times 10^{-23} \text{ J K}^{-1}$
gravitational constant,	$G = 6.67 \times 10^{-11} \text{ N m}^2 \text{ kg}^{-2}$
acceleration of free fall,	$g = 9.81 \text{ m s}^{-2}$

Formulae

uniformly accelerated motion,	$s = ut + \frac{1}{2}at^2$ $v^2 = u^2 + 2as$
work done on/by a gas,	$W = p\Delta V$
gravitational potential,	$\phi = -\frac{Gm}{r}$
hydrostatic pressure,	$p = \rho gh$
pressure of an ideal gas,	$p = \frac{1}{3}\frac{Nm}{V}\langle c^2 \rangle$
simple harmonic motion,	$a = -\omega^2 x$
velocity of particle in s.h.m.,	$v = v_0 \cos \omega t$ $v = \pm \omega \sqrt{(x_0^2 - x^2)}$
electric potential,	$V = \frac{Q}{4\pi\epsilon_0 r}$
capacitors in series,	$1/C = 1/C_1 + 1/C_2 + \dots$
capacitors in parallel,	$C = C_1 + C_2 + \dots$
energy of charged capacitor,	$W = \frac{1}{2}QV$
resistors in series,	$R = R_1 + R_2 + \dots$
resistors in parallel,	$1/R = 1/R_1 + 1/R_2 + \dots$
alternating current/voltage,	$x = x_0 \sin \omega t$
radioactive decay,	$x = x_0 \exp(-\lambda t)$
decay constant,	$\lambda = \frac{0.693}{t_{\frac{1}{2}}}$

Answer **all** the questions in the spaces provided.

- 1 (a) The intensity of a progressive wave is defined as the average power transmitted through a surface per unit area.

Show that the SI base units of intensity are kg s^{-3} .

[2]

- (b) (i) The intensity I of a sound wave is related to the amplitude x_0 of the wave by

$$I = K\rho cf^2x_0^2$$

where ρ is the density of the medium through which the sound is passing,
 c is the speed of the sound wave,
 f is the frequency of the sound wave
and K is a constant.

Show that K has no units.

[2]

(ii) Calculate the intensity, in pW m^{-2} , of a sound wave where

$$K = 20,$$

$$\rho = 1.2 \text{ in SI base units,}$$

$$c = 330 \text{ in SI base units,}$$

$$f = 260 \text{ in SI base units}$$

and $x_0 = 0.24 \text{ nm}.$

intensity = pW m^{-2} [3]

- 2 A signal generator is connected to two loudspeakers L_1 and L_2 , as shown in Fig. 2.1.

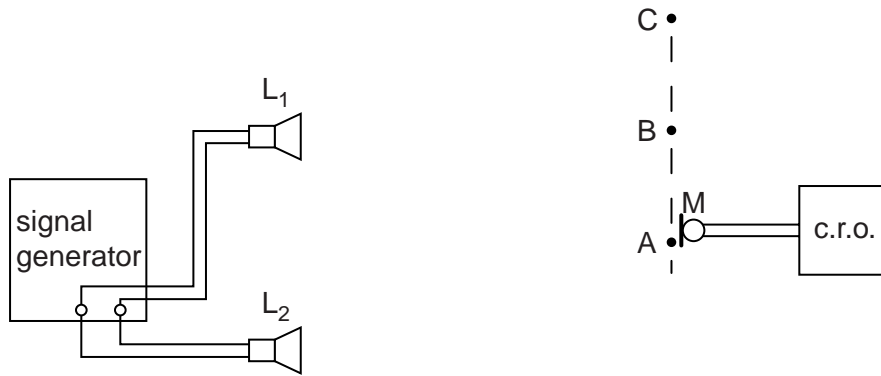
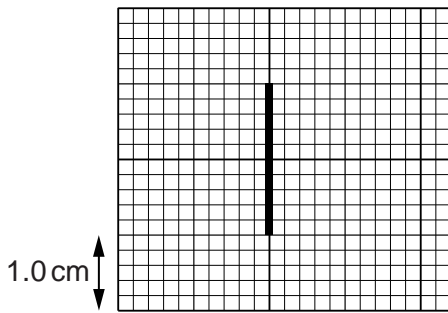

Fig. 2.1

A microphone M, connected to the Y-plates of a cathode-ray oscilloscope (c.r.o.), detects the intensity of sound along the line ABC. The distances L_1A and L_2A are equal. The time-base of the c.r.o. is switched off.

The traces on the c.r.o. when M is at A, then at B and then at C are shown on Fig. 2.2, Fig. 2.3 and Fig. 2.4 respectively.



M at A

Fig. 2.2

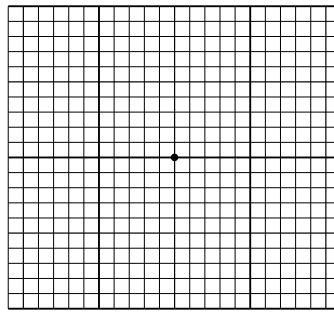

M at B

Fig. 2.3

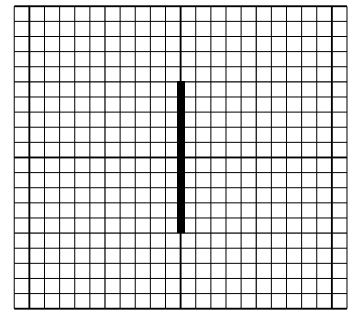

M at C

Fig. 2.4

For these traces, 1.0 cm represents 5.0 mV on the vertical scale.

- (a) (i) Explain why coherent waves are produced by the loudspeakers.

.....

[1]

(ii) Use the principle of superposition to explain the traces shown with M at

1. A,

.....

[1]

2. B,

.....

[1]

3. C.

.....

[1]

(b) The sound emitted from L_1 and L_2 has frequency 500Hz. The time-base on the c.r.o. is switched on.

The microphone M is placed at A.

On Fig. 2.5, draw the trace seen on the c.r.o.

On the vertical scale, 1.0 cm represents 5.0 mV. On the horizontal scale, 1.0 cm represents 0.10 ms.

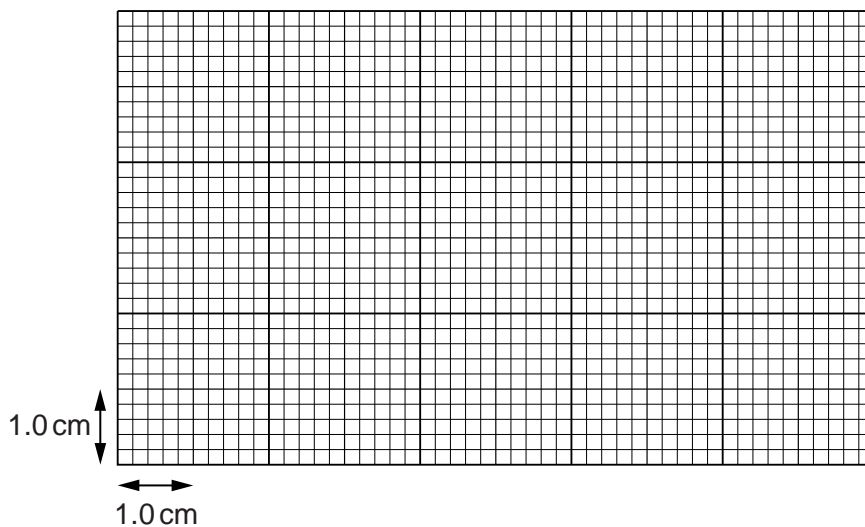

Fig. 2.5

[3]

- 3 A steel ball falls from a platform on a tower to the ground below, as shown in Fig. 3.1.

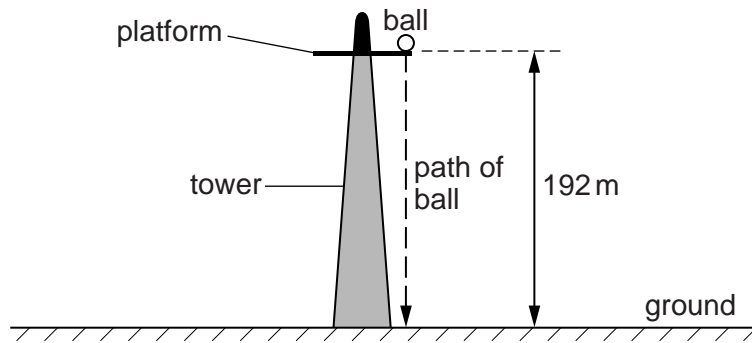

Fig. 3.1

The ball falls from rest through a vertical distance of 192 m. The mass of the ball is 270 g.

- (a) Assume air resistance is negligible.

(i) Calculate

1. the time taken for the ball to fall to the ground,

time taken = s [2]

2. the maximum kinetic energy of the ball.

maximum kinetic energy = J [2]

- (ii) State and explain the variation of the velocity of the ball with time as the ball falls to the ground.

.....
 [1]

- (iii) Show that the velocity of the ball on reaching the ground is approximately 60 m s^{-1} .

[1]

(b) In practice, air resistance is not negligible. The variation of the air resistance R with the velocity v of the ball is shown in Fig. 3.2.

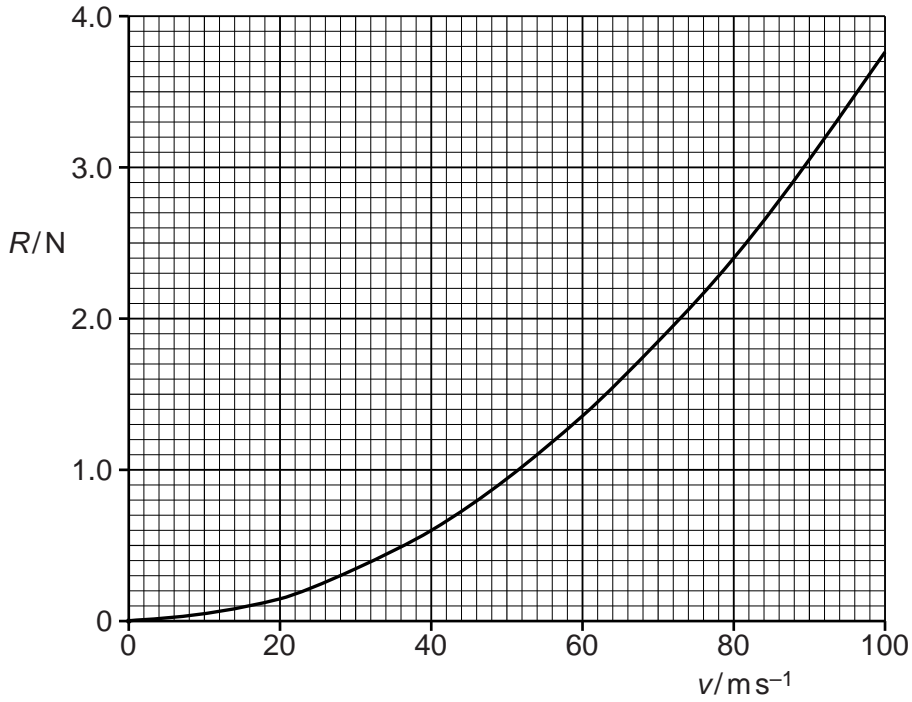

Fig. 3.2

(i) Use Fig. 3.2 to state and explain qualitatively the variation of the acceleration of the ball with the distance fallen by the ball.

.....

[3]

(ii) The speed of the ball reaches 40ms^{-1} . Calculate its acceleration at this speed.

acceleration = ms^{-2} [2]

(iii) Use information from (a)(iii) and Fig. 3.2 to state and explain whether the ball reaches terminal velocity.

.....

[2]

4 A block is pulled on a horizontal surface by a force P as shown in Fig. 4.1.

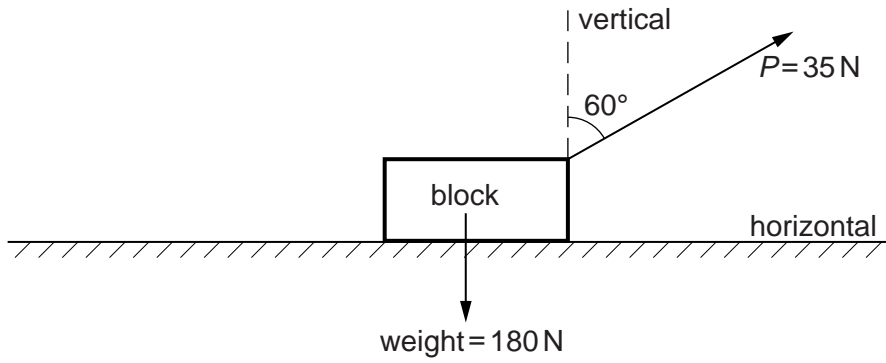

Fig. 4.1

The weight of the block is 180 N. The force P is 35 N at 60° to the vertical.
The block moves a distance of 20 m at constant velocity.

(a) Calculate

(i) the vertical force that the surface applies to the block (normal reaction force),

force = N [2]

(ii) the work done by force P .

work done = J [2]

(b) (i) Explain why the block continues to move at constant velocity although work is done on the block by force P .

.....
.....
.....[1]

(ii) Explain, in terms of the forces acting, why the block remains in equilibrium.

.....
.....
.....
.....[2]

5 (a) The I - V characteristic of a semiconductor diode is shown in Fig. 5.1.

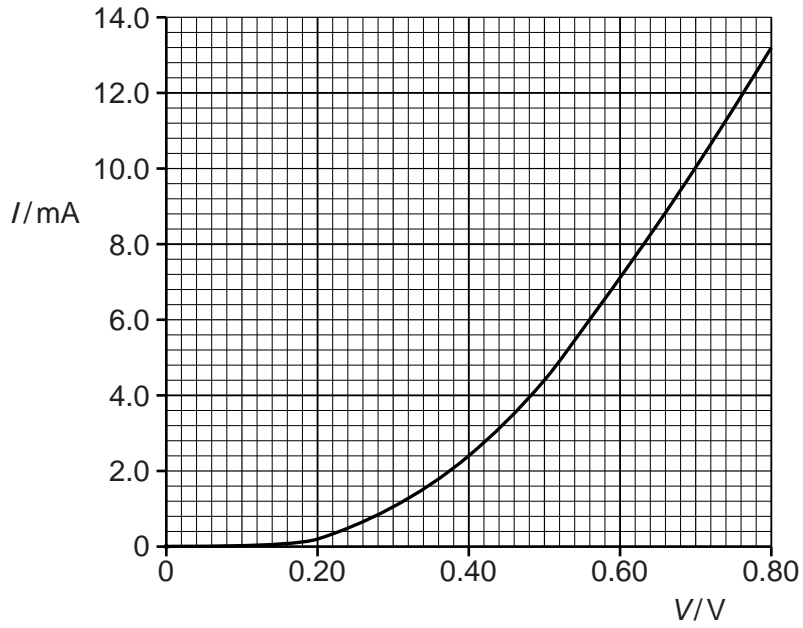

Fig. 5.1

(i) Use Fig. 5.1 to explain the variation of the resistance of the diode as V increases from zero to 0.8V.

.....

.....

.....

.....

.....

.....

.....

.....[3]

(ii) Use Fig. 5.1 to determine the resistance of the diode for a current of 4.4 mA.

resistance = Ω [2]

- (b) A cell of e.m.f. 1.2V and negligible internal resistance is connected in series to a semiconductor diode and a resistor R_1 , as shown in Fig. 5.2.

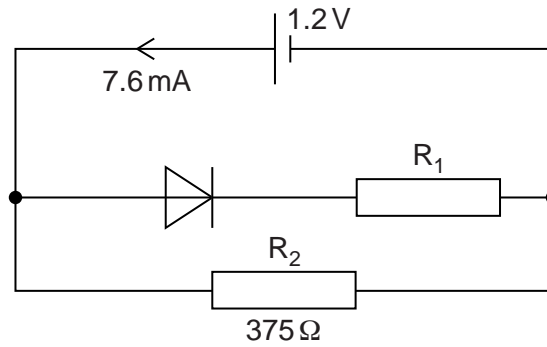

Fig. 5.2

A resistor R_2 of resistance 375Ω is connected across the cell. The diode has the characteristic shown in Fig. 5.1. The current supplied by the cell is 7.6 mA .

Calculate

- (i) the current in R_2 ,

current = A [1]

- (ii) the resistance of R_1 ,

resistance = Ω [2]

- (iii) the ratio

$$\frac{\text{power dissipated in the diode}}{\text{power dissipated in } R_2} .$$

ratio = [2]

- 6 An arrangement for producing stationary waves in air in a tube that is closed at one end is shown in Fig. 6.1.

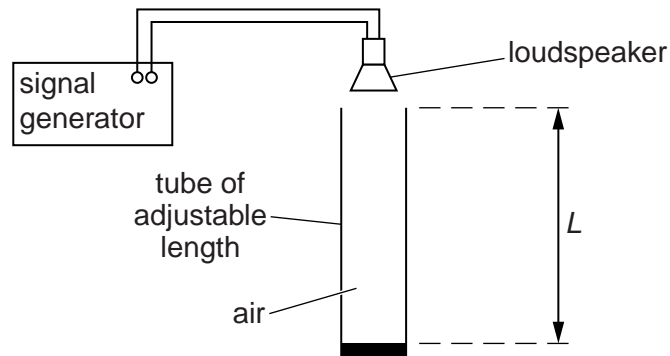

Fig. 6.1

A loudspeaker produces sound waves of wavelength 0.680 m in the tube. For some values of the length L of the tube, stationary waves are formed.

- (a) Explain how stationary waves are formed in the tube.

.....

 [2]

- (b) The length L is adjusted between 0.200 m and 1.00 m.

- (i) Calculate two values of L for which stationary waves are formed.

$L = \dots\dots\dots$ m and $L = \dots\dots\dots$ m [2]

- (ii) On Fig. 6.2, label the positions of the antinodes with an **A** and the nodes with an **N** for the least value of L for which a stationary wave is formed.



Fig. 6.2

[1]

7 A steel wire of cross-sectional area 15 mm^2 has an ultimate tensile stress of $4.5 \times 10^8 \text{ N m}^{-2}$.

(a) Calculate the maximum tension that can be applied to the wire.

tension = N [2]

(b) The steel of the wire has density 7800 kg m^{-3} . The wire is hung vertically.

Calculate the maximum length of the steel wire that could be hung vertically before the wire breaks under its own weight.

length = m [3]

**Please turn over for
Question 8.**

- 8 (a) State the quantities, other than momentum, that are conserved in a nuclear reaction.

.....
 [2]

- (b) A stationary nucleus of uranium-238 decays to a nucleus of thorium-234 by emitting an α -particle. The kinetic energy of the α -particle is 6.69×10^{-13} J.

- (i) Show that the kinetic energy E_k of a mass m is related to its momentum p by the equation

$$E_k = \frac{p^2}{2m}.$$

[1]

- (ii) Use the conservation of momentum to determine the kinetic energy, in keV, of the thorium nucleus.

kinetic energy = keV [3]

Permission to reproduce items where third-party owned material protected by copyright is included has been sought and cleared where possible. Every reasonable effort has been made by the publisher (UCLES) to trace copyright holders, but if any items requiring clearance have unwittingly been included, the publisher will be pleased to make amends at the earliest possible opportunity.

To avoid the issue of disclosure of answer-related information to candidates, all copyright acknowledgements are reproduced online in the Cambridge International Examinations Copyright Acknowledgements Booklet. This is produced for each series of examinations and is freely available to download at www.cie.org.uk after the live examination series.

Cambridge International Examinations is part of the Cambridge Assessment Group. Cambridge Assessment is the brand name of University of Cambridge Local Examinations Syndicate (UCLES), which is itself a department of the University of Cambridge.