

---

**COMPUTER SCIENCE**

**9608/11**

Paper 1 Written Paper

**May/June 2018**

MARK SCHEME

Maximum Mark: 75

---

**Published**

This mark scheme is published as an aid to teachers and candidates, to indicate the requirements of the examination. It shows the basis on which Examiners were instructed to award marks. It does not indicate the details of the discussions that took place at an Examiners' meeting before marking began, which would have considered the acceptability of alternative answers.

Mark schemes should be read in conjunction with the question paper and the Principal Examiner Report for Teachers.

Cambridge International will not enter into discussions about these mark schemes.

Cambridge International is publishing the mark schemes for the May/June 2018 series for most Cambridge IGCSE™, Cambridge International A and AS Level and Cambridge Pre-U components, and some Cambridge O Level components.

**Generic Marking Principles**

These general marking principles must be applied by all examiners when marking candidate answers. They should be applied alongside the specific content of the mark scheme or generic level descriptors for a question. Each question paper and mark scheme will also comply with these marking principles.

**GENERIC MARKING PRINCIPLE 1:**

Marks must be awarded in line with:

- the specific content of the mark scheme or the generic level descriptors for the question
- the specific skills defined in the mark scheme or in the generic level descriptors for the question
- the standard of response required by a candidate as exemplified by the standardisation scripts.

**GENERIC MARKING PRINCIPLE 2:**

Marks awarded are always **whole marks** (not half marks, or other fractions).

**GENERIC MARKING PRINCIPLE 3:**

Marks must be awarded **positively**:

- marks are awarded for correct/valid answers, as defined in the mark scheme. However, credit is given for valid answers which go beyond the scope of the syllabus and mark scheme, referring to your Team Leader as appropriate
- marks are awarded when candidates clearly demonstrate what they know and can do
- marks are not deducted for errors
- marks are not deducted for omissions
- answers should only be judged on the quality of spelling, punctuation and grammar when these features are specifically assessed by the question as indicated by the mark scheme. The meaning, however, should be unambiguous.

**GENERIC MARKING PRINCIPLE 4:**

Rules must be applied consistently e.g. in situations where candidates have not followed instructions or in the application of generic level descriptors.

**GENERIC MARKING PRINCIPLE 5:**

Marks should be awarded using the full range of marks defined in the mark scheme for the question (however; the use of the full mark range may be limited according to the quality of the candidate responses seen).

**GENERIC MARKING PRINCIPLE 6:**

Marks awarded are based solely on the requirements as defined in the mark scheme. Marks should not be awarded with grade thresholds or grade descriptors in mind.

Question	Answer	Marks
1	<p><b>1 mark</b> for a correct line from each communication media, <b>max 6</b></p>	<b>6</b>

Question	Answer	Marks
2(a)	<p><b>1 mark</b> per bullet, <b>max 2</b></p> <ul style="list-style-type: none"> <li>• Made up of pixels</li> <li>• Each pixel has one colour</li> <li>• Colour of each pixel stored as a binary number</li> </ul>	<b>2</b>
2(b)(i)	<p><b>1 mark</b> per bullet, <b>max 2</b></p> <ul style="list-style-type: none"> <li>• Each pixel requires only one bit (as there are only two colours)</li> <li>• Black represented by 1 and white by 0 (or vice versa)</li> <li>• Bits are stored for each pixel in sequence</li> <li>• 11111 01010 01010 01010 01010</li> </ul>	<b>2</b>
2(b)(ii)	<p><b>1 mark</b> for the explanation</p> <ul style="list-style-type: none"> <li>• Stores the colour and the number of times it occurs</li> </ul> <p><b>1 mark</b> for example from</p> <ul style="list-style-type: none"> <li>• An example from the bitmap given e.g. B5, W1, B1 and so on</li> </ul>	<b>2</b>
2(c)	<p><b>1 mark</b> per bullet</p> <ul style="list-style-type: none"> <li>• Number of pixels      <math>500 \times 1000 (= 500\,000)</math></li> <li>• 35 colours require    6 bits per pixel</li> <li>• Number of bytes      <math>(500\,000 \times 6) / 8 = 3\,000\,000 / 8 (= 375\,000)</math></li> <li>• = <b>375 Kb</b></li> </ul>	<b>4</b>

Question	Answer	Marks
2(d)	<b>1 mark</b> per bullet to <b>max 2</b> marks per benefit <ul style="list-style-type: none"> <li>• Can resize it without pixilation</li> <li>• Image is redrawn/recalculated with each adjustment</li> <li>• Smaller file size</li> <li>• Storing points/equations/commands etc., not individual pixels</li> </ul>	<b>4</b>

Question	Answer	Marks															
3(a)(i)	<b>1 mark</b> per bullet to <b>max 3</b> <ul style="list-style-type: none"> <li>• Allocates / deallocates RAM to programs/tasks/processes</li> <li>• Keeps track of allocated and free memory locations</li> <li>• Swaps data to and from the hard drive</li> <li>• Handles virtual memory</li> <li>• Paging // segmentation</li> <li>• Memory protection, preventing a process accessing memory not allocated to it</li> </ul>	<b>3</b>															
3(a)(ii)	<b>1 mark</b> per bullet to <b>max 3</b> <ul style="list-style-type: none"> <li>• Sets up user accounts</li> <li>• Checks usernames, passwords // Authentication</li> <li>• Implements access rights</li> <li>• <u>Automatic</u> backup</li> <li>• System restore / roll back (to previous stable state)</li> </ul>	<b>3</b>															
3(a)(iii)	<b>1 mark</b> per bullet to <b>max 2</b> <ul style="list-style-type: none"> <li>• Device / peripheral management</li> <li>• File management</li> <li>• Process management</li> <li>• Input / output management</li> <li>• Error detection / recovery</li> <li>• Provides a user interface</li> <li>• Facilitates communication between hardware and software / hardware devices</li> </ul>	<b>2</b>															
3(b)	<b>1 mark</b> for each correct box ticked <table border="1" style="margin-left: auto; margin-right: auto;"> <thead> <tr> <th>Programs</th> <th>True</th> <th>False</th> </tr> </thead> <tbody> <tr> <td>Disk Defragmenter</td> <td style="text-align: center;">✓</td> <td></td> </tr> <tr> <td>Word Processor</td> <td></td> <td style="text-align: center;">✓</td> </tr> <tr> <td>Library program</td> <td></td> <td style="text-align: center;">✓</td> </tr> <tr> <td>Compression Software</td> <td style="text-align: center;">✓</td> <td></td> </tr> </tbody> </table>	Programs	True	False	Disk Defragmenter	✓		Word Processor		✓	Library program		✓	Compression Software	✓		<b>4</b>
Programs	True	False															
Disk Defragmenter	✓																
Word Processor		✓															
Library program		✓															
Compression Software	✓																

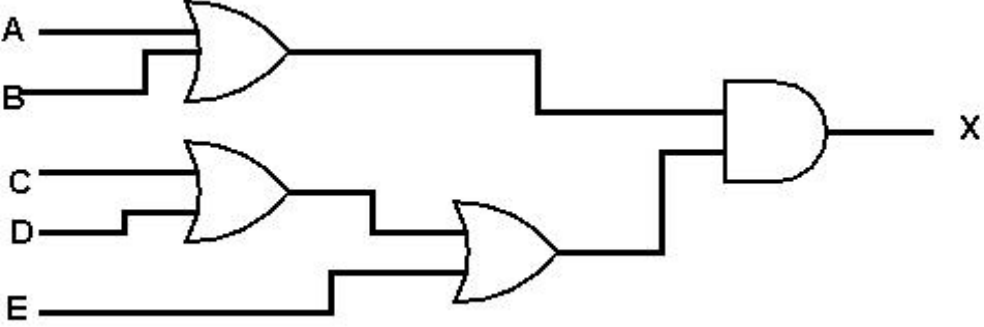
Question	Answer	Marks																																													
4(a)	<p>1 mark per bullet:</p> <ul style="list-style-type: none"> <li>• A OR B</li> <li>• C OR D OR E</li> <li>• Final AND</li> </ul> 	<b>3</b>																																													
4(b)	<p>1 mark for each correct pair of rows</p> <table border="1" data-bbox="363 875 1249 1585"> <thead> <tr> <th>A</th> <th>B</th> <th>C</th> <th>Working space</th> <th>X</th> </tr> </thead> <tbody> <tr> <td>0</td> <td>0</td> <td>0</td> <td style="background-color: #cccccc;"></td> <td>0</td> </tr> <tr> <td>0</td> <td>0</td> <td>1</td> <td style="background-color: #cccccc;"></td> <td>1</td> </tr> <tr> <td>0</td> <td>1</td> <td>0</td> <td></td> <td>1</td> </tr> <tr> <td>0</td> <td>1</td> <td>1</td> <td></td> <td>0</td> </tr> <tr> <td>1</td> <td>0</td> <td>0</td> <td style="background-color: #cccccc;"></td> <td>1</td> </tr> <tr> <td>1</td> <td>0</td> <td>1</td> <td style="background-color: #cccccc;"></td> <td>1</td> </tr> <tr> <td>1</td> <td>1</td> <td>0</td> <td></td> <td>1</td> </tr> <tr> <td>1</td> <td>1</td> <td>1</td> <td></td> <td>1</td> </tr> </tbody> </table>	A	B	C	Working space	X	0	0	0		0	0	0	1		1	0	1	0		1	0	1	1		0	1	0	0		1	1	0	1		1	1	1	0		1	1	1	1		1	<b>4</b>
A	B	C	Working space	X																																											
0	0	0		0																																											
0	0	1		1																																											
0	1	0		1																																											
0	1	1		0																																											
1	0	0		1																																											
1	0	1		1																																											
1	1	0		1																																											
1	1	1		1																																											

Question	Answer	Marks				
5(a)	<p><b>1 mark</b> per server</p> <p>e.g.</p> <ul style="list-style-type: none"> <li>• E-mail</li> <li>• Print</li> <li>• Web</li> </ul>	<b>2</b>				
5(b)	<p><b>1 mark</b> for the indicating the statement is false:</p> <table border="1" style="margin-left: auto; margin-right: auto;"> <tr> <td>True</td> <td>False</td> </tr> <tr> <td></td> <td style="text-align: center;">✓</td> </tr> </table> <p><b>1 mark</b> per bullet for justification to <b>max 4</b>.</p> <ul style="list-style-type: none"> <li>• Internet is the infrastructure / global collection of networks</li> <li>• World Wide Web is the (multimedia web) pages / content</li> <li>• The World Wide Web is accessed over the Internet</li> <li>• Webpages are written in HTML</li> <li>• HTTP protocol used to transfer web pages</li> <li>• Internet uses IP protocol</li> </ul>	True	False		✓	<b>5</b>
True	False					
	✓					
5(c)	<p><b>1 mark</b> per bullet to <b>max 4</b></p> <ul style="list-style-type: none"> <li>• The <u>browser</u> requests the web page</li> <li>• The web server accesses the page</li> <li>• The web server processes / executes the code</li> <li>• The web server produces the HTML for the web page / generates the web page</li> <li>• The web server returns the web page to the client</li> <li>• The client browser displays this web page</li> </ul>	<b>4</b>				

Question	Answer	Marks								
6(a)	<p><b>1 mark</b> for the correct parity</p> <p><b>Parity bit</b></p> <table border="1" style="margin-left: auto; margin-right: auto;"> <tr> <td style="background-color: #e0e0e0;">0</td> <td>0</td> <td>1</td> <td>0</td> <td>0</td> <td>0</td> <td>0</td> <td>0</td> </tr> </table>	0	0	1	0	0	0	0	0	<b>1</b>
0	0	1	0	0	0	0	0			

Question	Answer	Marks																																																	
6(b)(i)	<p><b>1 mark</b> for the correct bit circled</p> <table border="1" data-bbox="300 315 1289 752"> <thead> <tr> <th data-bbox="411 315 520 389">Parity bit</th> <th colspan="7" data-bbox="520 315 1289 389">Data</th> </tr> </thead> <tbody> <tr> <td data-bbox="411 389 520 463">1</td> <td data-bbox="520 389 628 463">1</td> <td data-bbox="628 389 737 463">0</td> <td data-bbox="737 389 845 463">1</td> <td data-bbox="845 389 954 463">0</td> <td data-bbox="954 389 1062 463">1</td> <td data-bbox="1062 389 1171 463">1</td> <td data-bbox="1171 389 1289 463">1</td> </tr> <tr> <td data-bbox="411 463 520 537">1</td> <td data-bbox="520 463 628 537">0</td> <td data-bbox="628 463 737 537">0</td> <td data-bbox="737 463 845 537">0</td> <td data-bbox="845 463 954 537">1</td> <td data-bbox="954 463 1062 537">1</td> <td data-bbox="1062 463 1171 537">1</td> <td data-bbox="1171 463 1289 537">0</td> </tr> <tr> <td data-bbox="411 537 520 611">0</td> <td data-bbox="520 537 628 611">1</td> <td data-bbox="628 537 737 611">0</td> <td data-bbox="737 537 845 611">0</td> <td data-bbox="845 537 954 611">1</td> <td data-bbox="954 537 1062 611">0</td> <td data-bbox="1062 537 1171 611">1</td> <td data-bbox="1171 537 1289 611">1</td> </tr> <tr> <td data-bbox="411 611 520 685">1</td> <td data-bbox="520 611 628 685">1</td> <td data-bbox="628 611 737 685">1</td> <td data-bbox="737 611 845 685">0</td> <td data-bbox="845 611 954 685">1</td> <td data-bbox="954 611 1062 685" style="text-align: center;"><b>1</b></td> <td data-bbox="1062 611 1171 685">1</td> <td data-bbox="1171 611 1289 685">1</td> </tr> <tr> <td data-bbox="300 685 411 752"><b>Parity byte</b></td> <td data-bbox="411 685 520 752">1</td> <td data-bbox="520 685 628 752">1</td> <td data-bbox="628 685 737 752">1</td> <td data-bbox="737 685 845 752">1</td> <td data-bbox="845 685 954 752">1</td> <td data-bbox="954 685 1062 752">0</td> <td data-bbox="1062 685 1171 752">0</td> <td data-bbox="1171 685 1289 752">1</td> </tr> </tbody> </table>	Parity bit	Data							1	1	0	1	0	1	1	1	1	0	0	0	1	1	1	0	0	1	0	0	1	0	1	1	1	1	1	0	1	<b>1</b>	1	1	<b>Parity byte</b>	1	1	1	1	1	0	0	1	<b>1</b>
Parity bit	Data																																																		
1	1	0	1	0	1	1	1																																												
1	0	0	0	1	1	1	0																																												
0	1	0	0	1	0	1	1																																												
1	1	1	0	1	<b>1</b>	1	1																																												
<b>Parity byte</b>	1	1	1	1	1	0	0	1																																											
6(b)(ii)	<p><b>1 mark</b> for each bullet point</p> <ul style="list-style-type: none"> <li>• row and column has incorrect parity (odd instead of even)</li> <li>• the intersection identifies the error</li> </ul>	<b>2</b>																																																	
6(c)	<p><b>1 mark</b> per bullet to <b>max 2</b></p> <ul style="list-style-type: none"> <li>• Errors in an even number of bits (in the same row or column)</li> <li>• Prevents error being identified</li> <li>• Could appear to be correct</li> </ul>	<b>2</b>																																																	
6(d)	<p><b>1 mark</b> for the name and <b>max 2</b> marks for description</p> <ul style="list-style-type: none"> <li>• <b>Check sum</b></li> <li>• A calculation is done on a block of data</li> <li>• The result is transmitted with the data</li> <li>• Calculation repeated at receiving end</li> <li>• Results compared</li> <li>• If different an error has occurred</li>   <li>• <b>Hash total</b></li> <li>• Total of several fields of data</li> <li>• Including fields not usually used in calculations</li> <li>• The result is transmitted with the data</li> <li>• Calculation repeated at receiving end</li> <li>• Results compared</li> <li>• If different an error has occurred</li> </ul>	<b>3</b>																																																	

Question	Answer	Marks
7(a)	<p><b>1 mark</b> for each input device to <b>max 2</b></p> <p>e.g.</p> <ul style="list-style-type: none"> <li>• (Handheld) remote controller</li> <li>• Joystick / Games pad / joypad</li> <li>• Accelerometer</li> <li>• Microphone</li> <li>• Suitable sensor</li> </ul> <p><b>1 mark</b> for output</p> <p>e.g.</p> <ul style="list-style-type: none"> <li>• Motor/vibrator in joystick</li> <li>• Speaker</li> <li>• Screen/monitor /TV</li> </ul>	<b>3</b>
7(b)(i)	<p><b>1 mark</b> for each difference to <b>max 2</b></p> <ul style="list-style-type: none"> <li>• RAM is volatile and ROM is non-volatile</li> <li>• RAM can change and ROM (usually) can't be changed</li> <li>• ROM is read only, RAM is read/write</li> </ul>	<b>2</b>
7(b)(ii)	<p><b>1 mark</b> for example</p> <p>e.g.</p> <ul style="list-style-type: none"> <li>• Current game</li> <li>• Currently running processes</li> <li>• Current graphics/sound</li> </ul>	<b>1</b>
7(b)(iii)	<p><b>1 mark</b> for an example</p> <p>e.g.</p> <ul style="list-style-type: none"> <li>• Start-up instructions / boot program</li> <li>• Kernel of Operating System</li> </ul>	<b>1</b>

Question	Answer	Marks
8(a)	<p><b>1 mark</b> per bullet to <b>max 2</b></p> <ul style="list-style-type: none"> <li>• Small piece / word of (fast) memory</li> <li>• Part of the processor</li> <li>• Temporary storage of data</li> <li>• Data is about to be / has been processed</li> </ul>	<b>2</b>
8(b)(i)	<p><b>1 mark</b> per bullet to <b>max 2</b></p> <ul style="list-style-type: none"> <li>• Stores / holds data / instruction when fetched from memory</li> <li>• Stores / holds data which is being written to memory</li> <li>• The location accessed is the address held in the Memory Address Register (MAR)</li> </ul>	<b>2</b>



Question	Answer	Marks
8(b)(ii)	<b>1 mark</b> per bullet to <b>max 2</b> <ul style="list-style-type: none"><li>• Current Instruction Register (CIR)</li><li>• Memory Address Register (MAR)</li><li>• Program Counter (PC)</li><li>• Accumulator (ACC)</li><li>• Index Register (IX)</li><li>• Status Register</li><li>• Interrupt Register</li></ul>	<b>2</b>
8(c)(i)	135	<b>1</b>
8(c)(ii)	87	<b>1</b>
8(c)(iii)	–121	<b>1</b>