



Cambridge International Examinations
Cambridge International General Certificate of Secondary Education

PHYSICS

0625/11

Paper 1 Multiple Choice (Core)

October/November 2018

45 minutes

Additional Materials: Multiple Choice Answer Sheet
Soft clean eraser
Soft pencil (type B or HB recommended)

* 2 7 7 7 9 9 1 6 5 7 *

READ THESE INSTRUCTIONS FIRST

Write in soft pencil.

Do not use staples, paper clips, glue or correction fluid.

Write your name, Centre number and candidate number on the Answer Sheet in the spaces provided unless this has been done for you.

DO NOT WRITE IN ANY BARCODES.

There are **forty** questions on this paper. Answer **all** questions. For each question there are four possible answers **A, B, C** and **D**.

Choose the **one** you consider correct and record your choice in **soft pencil** on the separate Answer Sheet.

Read the instructions on the Answer Sheet very carefully.

Each correct answer will score one mark. A mark will not be deducted for a wrong answer.

Any rough working should be done in this booklet.

Electronic calculators may be used.

Take the weight of 1.0 kg to be 10 N (acceleration of free fall = 10 m/s^2).

bestexamhelp.com

The syllabus is approved for use in England, Wales and Northern Ireland as a Cambridge International Level 1/Level 2 Certificate.

This document consists of **16** printed pages.

- 1 A pendulum is set in motion and timed. The time measured for 20 complete swings is 30 s.

What is the time for one complete swing of the pendulum?

- A 0.67 s B 0.75 s C 1.5 s D 3.0 s

- 2 The diagrams are distance-time graphs for four bodies.

Which body is moving with an increasing speed?

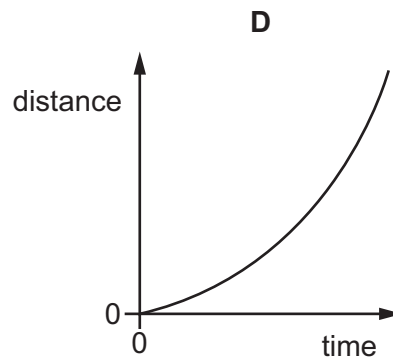
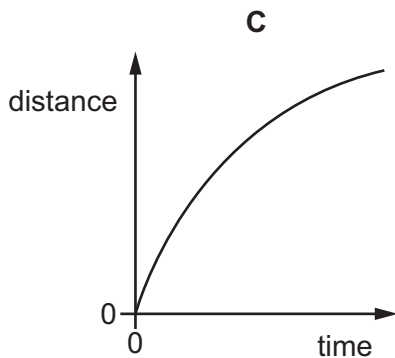
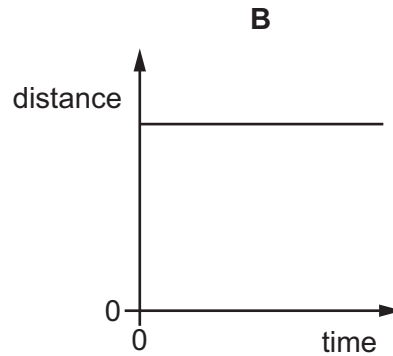
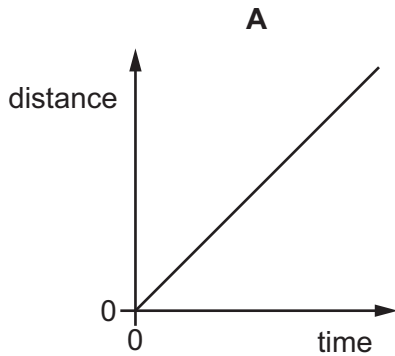

- 3 A runner runs 300 m at an average speed of 3.0 m/s. She then runs another 300 m at an average speed of 6.0 m/s.

What is her average speed for the total distance of 600 m?

- A 2.0 m/s B 4.0 m/s C 4.5 m/s D 8.0 m/s

- 4 Which quantity is measured in newtons?

- A energy
B mass
C weight
D work

- 5 Four identical steel blocks are placed on a balance. The reading on the balance is 220 N.

What is the mass of one steel block?

- A 5.5 kg B 22 kg C 55 kg D 88 kg

- 6 A liquid has a volume of 0.040 m^3 and a mass of 30 000 g.

What is the density of the liquid?

- A 0.075 kg/m^3 B 7.5 kg/m^3 C 750 kg/m^3 D 7500 kg/m^3

- 7 The unstretched lengths and extension-load graphs are shown for each of four different springs.

Which spring is the longest when a load of 5.0 N is hung from each spring?

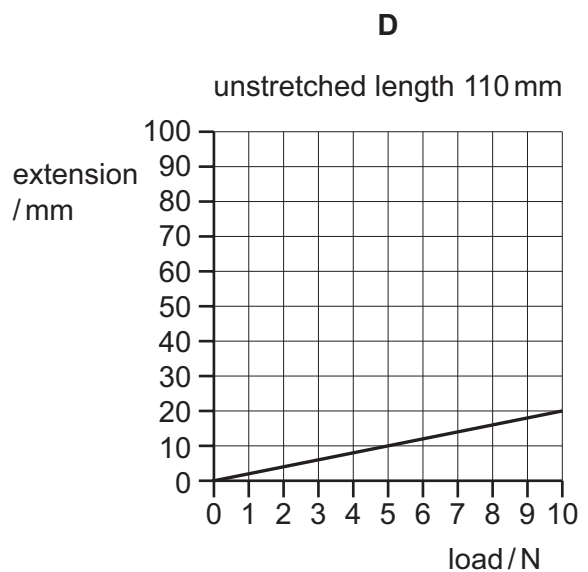
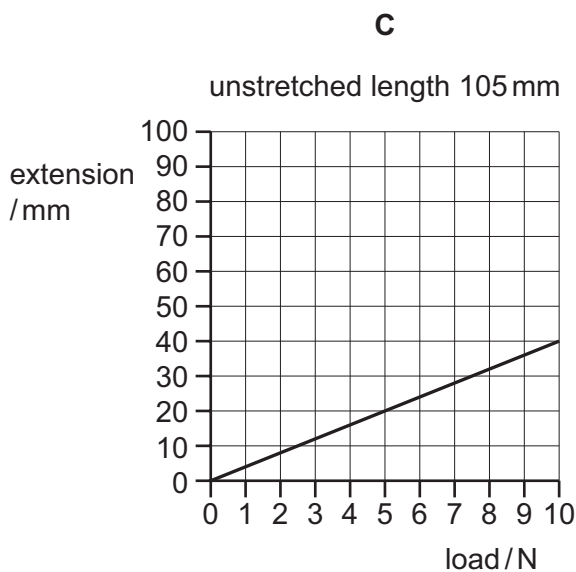
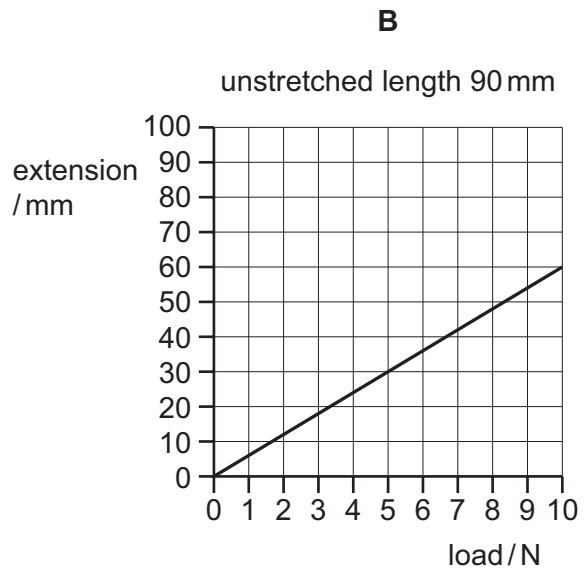
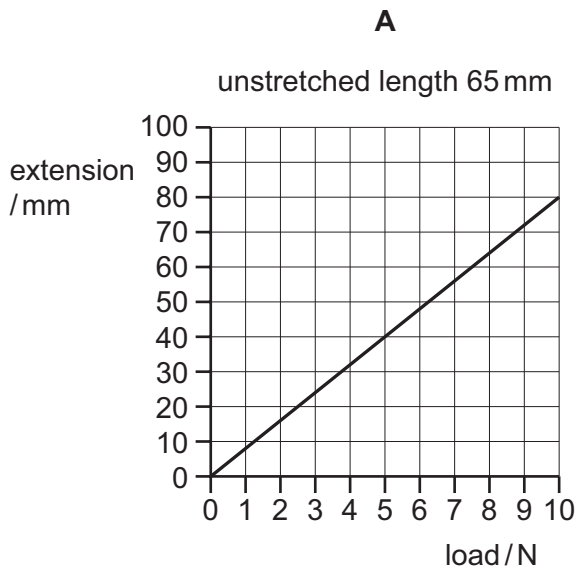

- 8 A car moves along a level road.

The diagram shows all of the horizontal forces acting on the car.

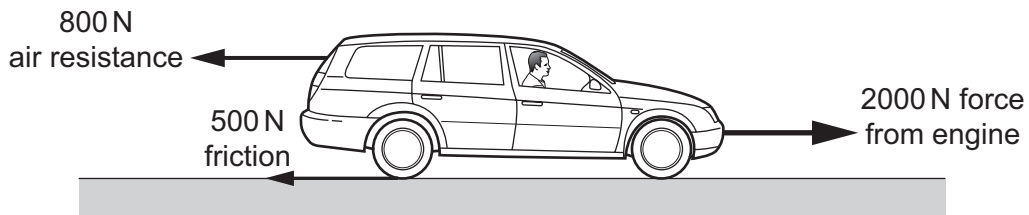

Which statement is correct?

- A** The car is slowing down.
- B** The car is speeding up.
- C** The car is moving at a constant speed.
- D** The car is moving backwards.
- 9 Which force and distance produce the smallest moment about a pivot?
- A** a 6.0 N force at a perpendicular distance of 4.0 m from the pivot
- B** a 7.0 N force at a perpendicular distance of 6.0 m from the pivot
- C** a 10 N force at a perpendicular distance of 4.0 m from the pivot
- D** a 12 N force at a perpendicular distance of 3.0 m from the pivot
- 10 Which device is designed to convert chemical energy into kinetic energy?
- A** an a.c. generator
- B** a battery-powered torch
- C** a car engine
- D** a wind-up mechanical clock
- 11 A man climbs a ladder.
- Which two quantities can be used to calculate the useful power of the man?
- A** the weight of the man and the time taken only
- B** the weight of the man and the vertical distance moved only
- C** the work done by the man and the time taken only
- D** the work done by the man and the vertical distance moved only

12 A manometer is used to measure the pressure of gas inside a metal container.

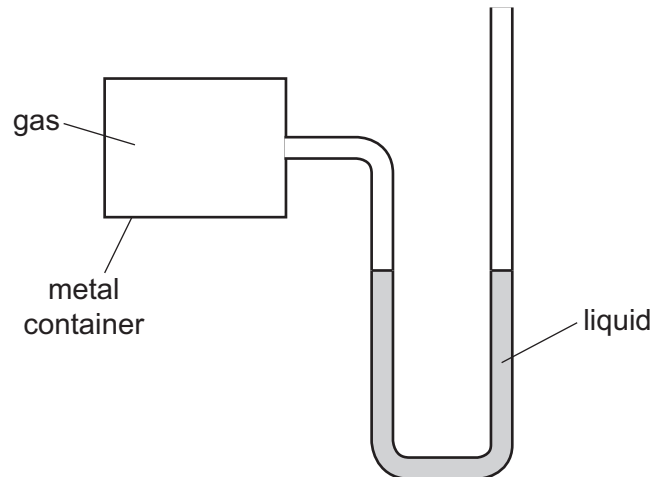

What is the pressure inside the container?

- A equal to the atmospheric pressure
- B greater than the atmospheric pressure
- C less than the atmospheric pressure but greater than zero
- D zero

13 A manometer is used to measure the pressure of a gas supply.

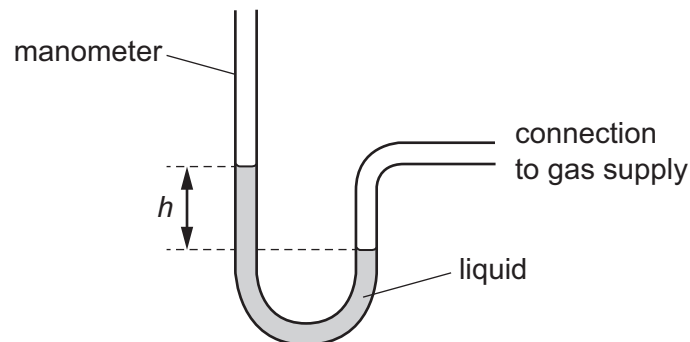

Which change gives a greater value of height h ?

- A using a less dense liquid
- B using a more dense liquid
- C using a narrower tube
- D using a wider tube

- 14 During evaporation of a liquid, the more energetic molecules escape. The temperature of the remaining liquid changes.

Which row identifies where these molecules escape from and describes the temperature change?

	molecules escape from the	temperature of remaining liquid
A	body of the liquid	decreases
B	body of the liquid	increases
C	surface of the liquid	decreases
D	surface of the liquid	increases

- 15 Diagram 1 shows apparatus being used to observe smoke particles.

Diagram 2 shows how a smoke particle moves randomly.

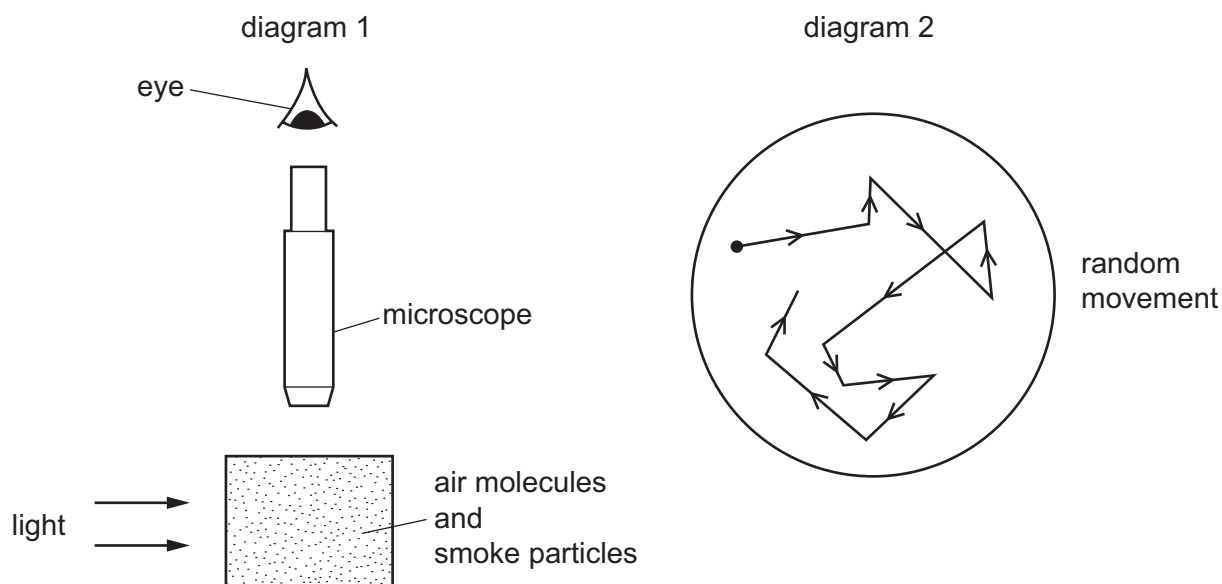

Why do the smoke particles move randomly?

- A** They are hit by air molecules.
- B** They are less dense than air.
- C** They are moved by convection currents.
- D** They gain energy from the light.

- 16 The distance between two electricity pylons is 60 m. An engineer fits a cable of length 62 m between the pylons.

Why does the engineer choose a cable that is longer than the distance between the two pylons?

- A to allow for contraction of the cable in cold weather
 - B to create a slope in the cable for electrons to flow down
 - C to keep the current low and the voltage high
 - D to reduce magnetic fields around the cable
- 17 Some ice is slowly heated and its temperature is measured. A graph is plotted of temperature against time.

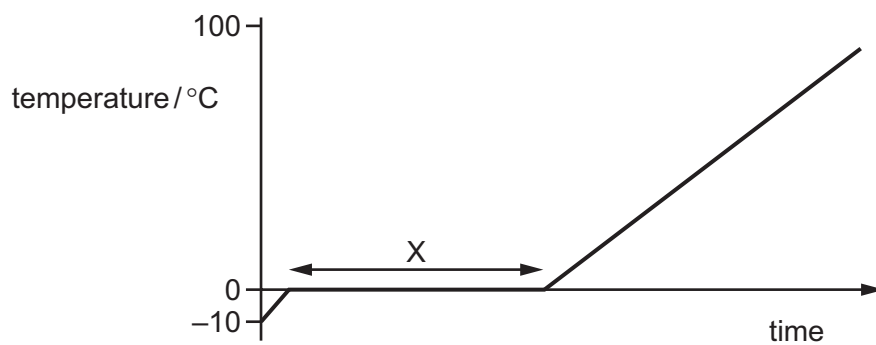

Which row describes what happens to the thermal energy and to the temperature in section X?

	thermal energy	temperature of ice
A	gained by ice	rises
B	gained by ice	stays the same
C	not gained by ice	rises
D	not gained by ice	stays the same

- 18 Some of the Sun's radiation passes through a prism. The diagram shows the spectrum of the radiation.

Which point on the screen does the infra-red radiation reach?

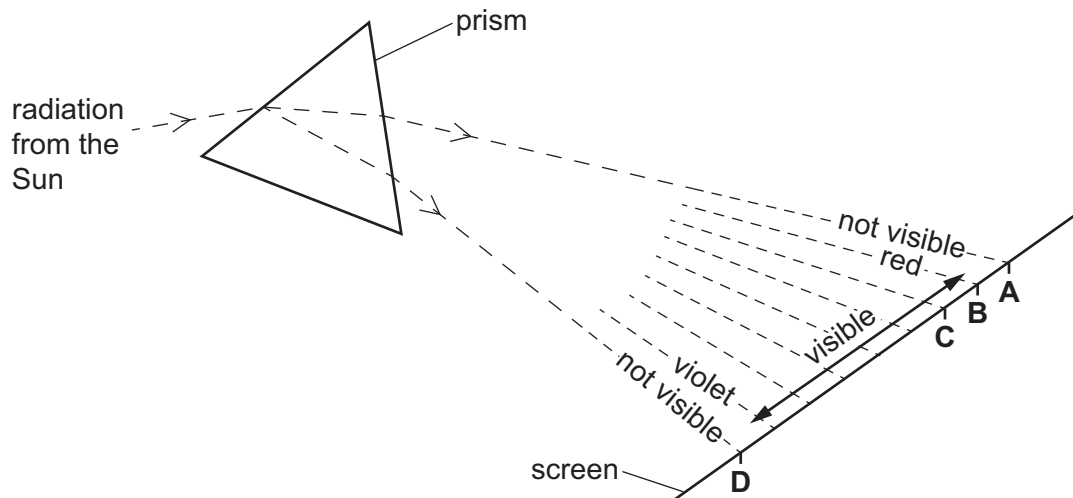

- 19 On a cold day, a shiny metal rod feels colder to the touch than a black plastic rod.

Which statement explains this observation?

- A The metal rod is a better absorber of infra-red radiation than the plastic rod.
 - B The metal rod is a better thermal conductor than the plastic rod.
 - C The metal rod is a worse absorber of infra-red radiation than the plastic rod.
 - D The metal rod is a worse thermal conductor than the plastic rod.
- 20 A boat moves up and down repeatedly as a water wave passes it.
- Which name is given to the number of up-and-down movements of the boat per unit time?
- A amplitude
 - B frequency
 - C speed
 - D wavelength

21 Plane water waves travel from a shallow region into a deeper region. They travel more quickly in the deeper water.

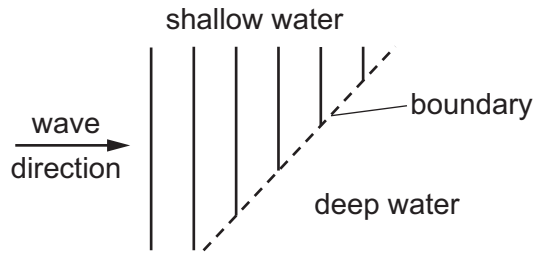

Which diagram shows the wave pattern in the deeper water?

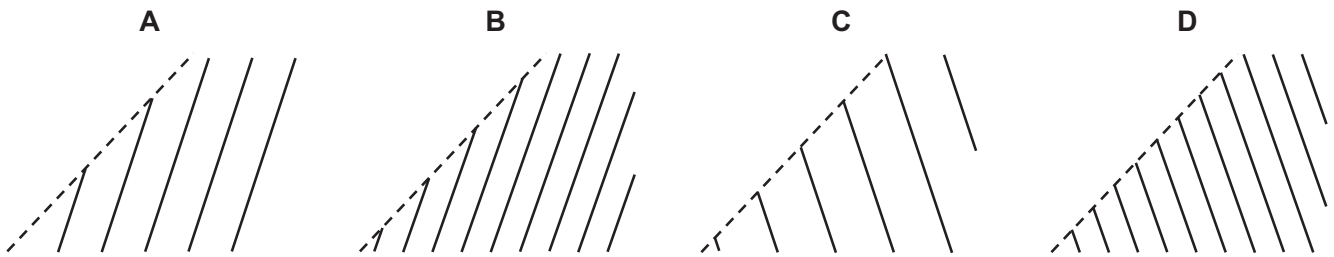

22 A parallel beam of light is incident on a plane mirror.

Which diagram shows how the beam is reflected by the mirror?

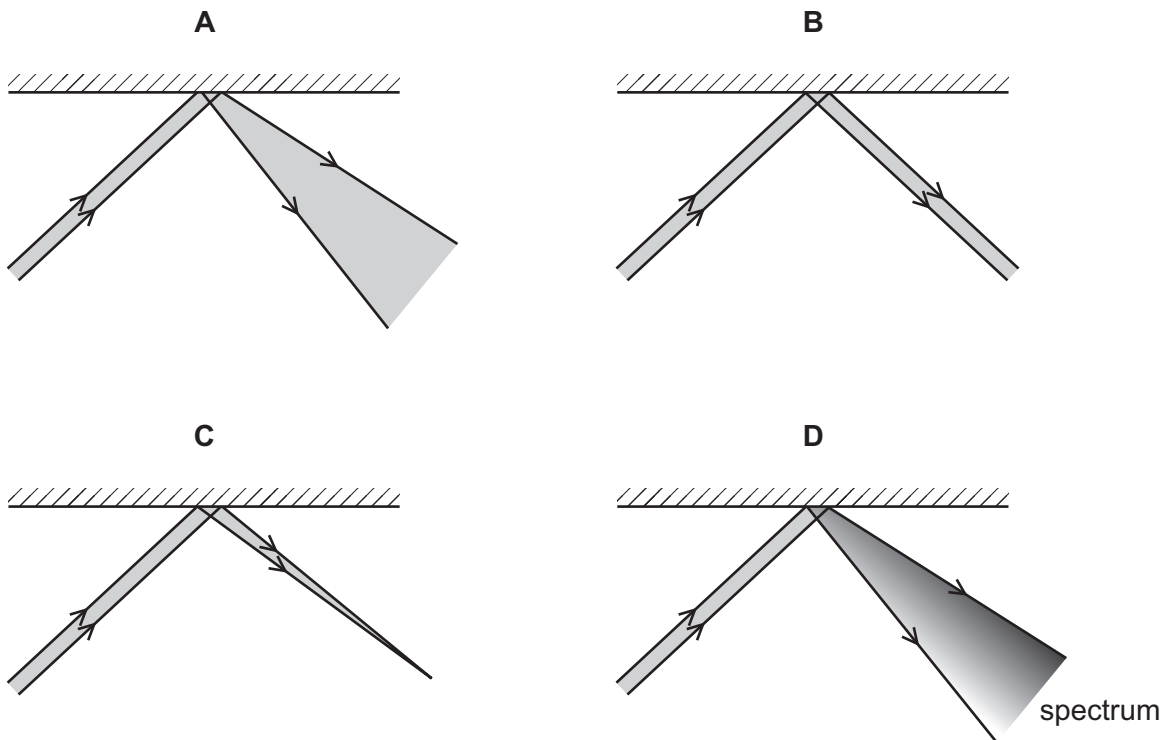

- 23 The diagram shows a parallel, cylindrical light beam of diameter d incident on a thin converging lens. A screen is placed a distance equal to two focal lengths $2f$ from the lens.

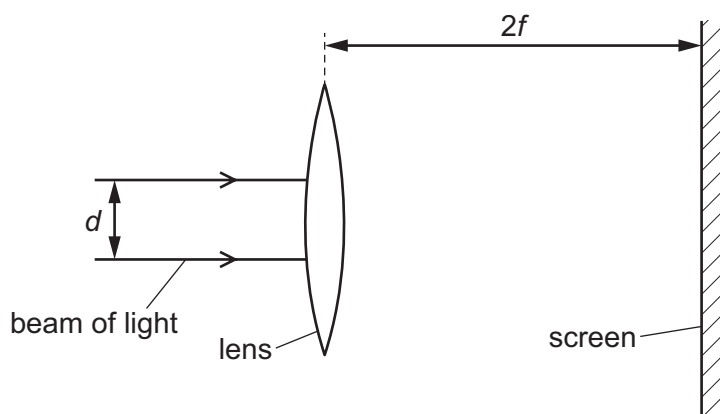

Which diagram shows the size of the spot of light seen on the screen?

A

•

B



C



D

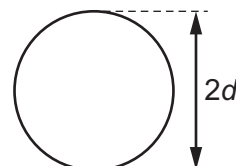

- 24 Different parts of the electromagnetic spectrum are used for different purposes. Below are four statements about parts of the spectrum.

statement 1: Infra-red waves are used in television remote controllers.

statement 2: Radio waves are used to transmit television pictures from satellites to Earth.

statement 3: Ultraviolet waves are used for intruder alarms.

statement 4: X-rays are used for security checks.

Which statements are correct?

A 1 and 2

B 1 and 4

C 2 and 3

D 3 and 4

25 A woman hears the first note produced by a clarinet.

She then hears a second note that has a higher pitch and is quieter.

Which row compares the frequency and the amplitude of the two notes?

	first note	second note
A	higher frequency	larger amplitude
B	higher frequency	smaller amplitude
C	lower frequency	larger amplitude
D	lower frequency	smaller amplitude

26 The diagram shows a bar magnet and four plotting compasses.

Which compass shows the direction of the magnetic field due to the magnet?

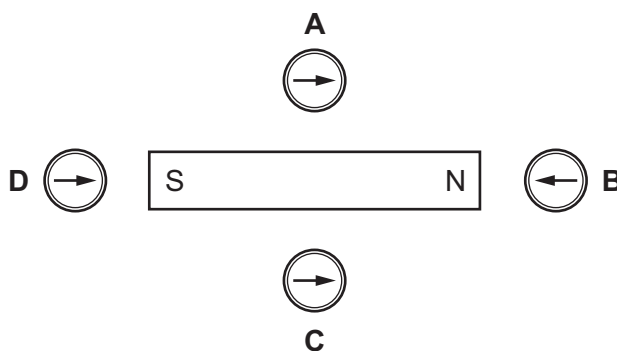

27 Iron is used for the core of a transformer and steel is used to make a bar magnet.

Which statement explains these uses of iron and of steel?

- A** Iron is a magnetic material and steel is a non-magnetic material.
- B** Iron is a permanent magnetic material and steel is a temporary magnetic material.
- C** Iron is a temporary magnetic material and steel is a permanent magnetic material.
- D** Iron is a non-magnetic material and steel is a magnetic material.

28 A negatively charged plastic rod P is placed above a positively charged plastic rod Q.

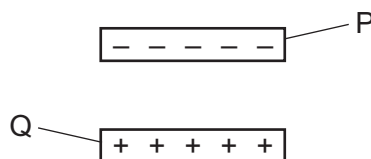

What are the directions of the electrostatic forces on rod P and on rod Q?

	electrostatic force on rod P	electrostatic force on rod Q
A	downwards	downwards
B	downwards	upwards
C	upwards	downwards
D	upwards	upwards

29 The diagrams show the scales of three ammeters.

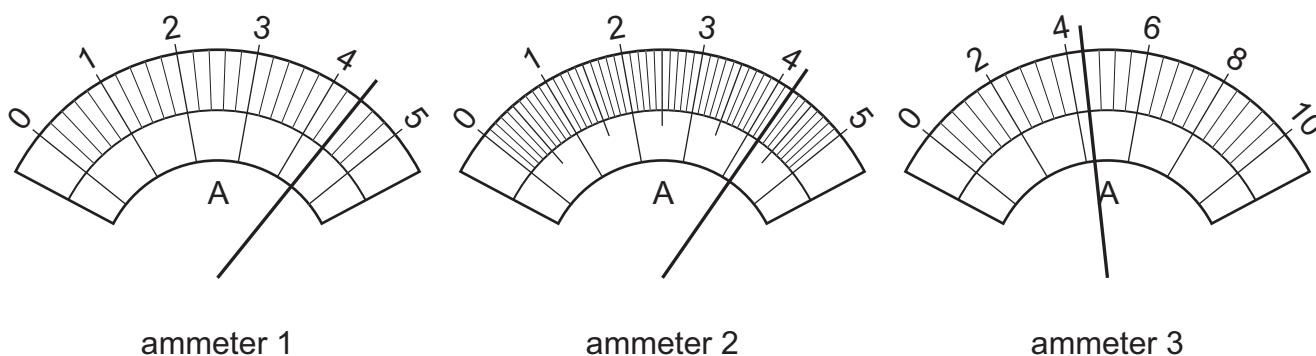

Which ammeters show the same current reading?

- A** all three ammeters
 - B** ammeter 1 and ammeter 2 only
 - C** ammeter 1 and ammeter 3 only
 - D** ammeter 2 and ammeter 3 only
- 30 The resistance of a component in a circuit is found using an ammeter and a voltmeter.

How are the ammeter and the voltmeter connected?

- A** the voltmeter and ammeter in parallel with the component
- B** the voltmeter and ammeter in series with the component
- C** the voltmeter in parallel with the component and the ammeter in series with the component
- D** the voltmeter in series with the component and the ammeter in parallel with the component

31 The diagram shows a circuit with a power supply and four components.

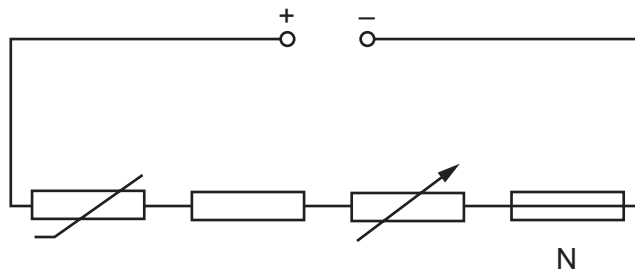

What is component N?

- A fixed resistor
- B fuse
- C thermistor
- D variable resistor

32 Two lamps are connected in parallel.

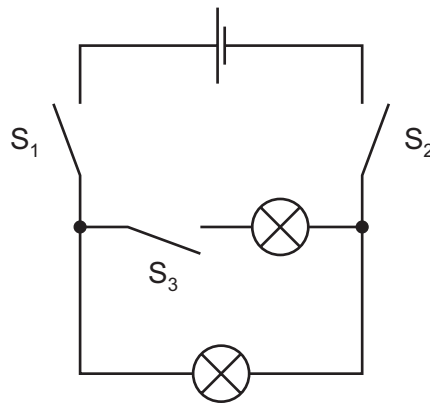

Which switches must be closed so that both lamps light?

- A S_1 and S_2 only
- B S_1 and S_3 only
- C S_2 and S_3 only
- D S_1 , S_2 and S_3

- 33 The circuit diagram shows a variable potential divider.

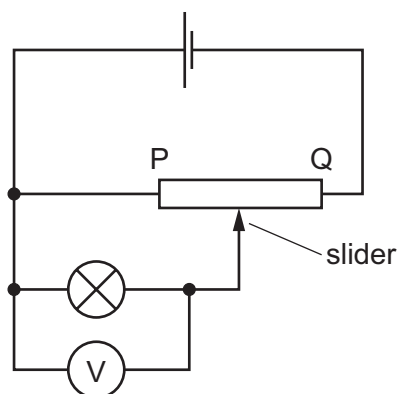

The slider is moved from P towards Q.

What happens to the reading on the voltmeter and to the brightness of the lamp?

	reading on voltmeter	brightness of lamp
A	decreases	decreases
B	decreases	increases
C	increases	decreases
D	increases	increases

- 34 Either a fuse or a circuit-breaker can be used to protect electrical cables from large currents that could cause overheating.

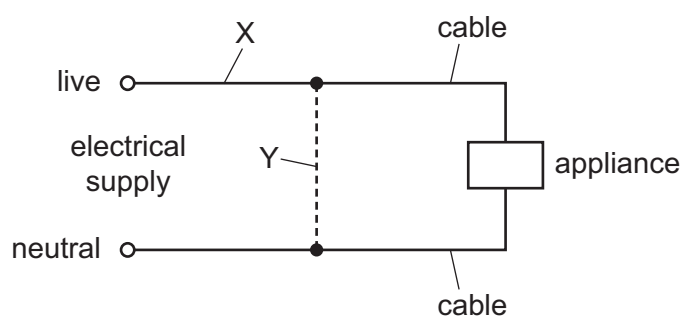

When a fuse is used, where should it be connected, and when a circuit-breaker is used, where should it be connected?

	position of fuse	position of circuit-breaker
A	X	X
B	X	Y
C	Y	X
D	Y	Y

- 35 Which electrical device uses the turning effect produced by a current-carrying coil in a magnetic field?
- A a.c. generator
 B d.c. motor
 C relay
 D transformer
- 36 A wire is placed in a strong magnetic field. When a current is passed through the wire it moves upwards, as shown.

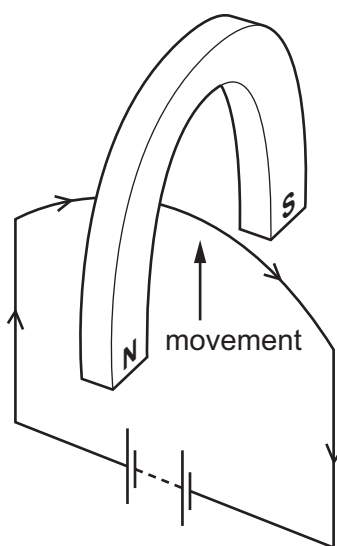

The current is reversed.

In which direction does the wire move?

- A downwards
 B towards the north pole
 C towards the south pole
 D upwards
- 37 Which diagram represents the structure of a neutral atom?

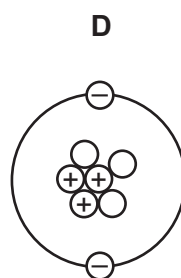
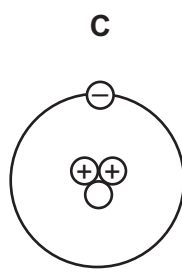
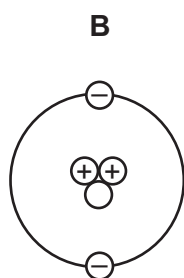
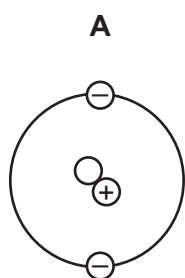

key
 ○ neutron
 ⊕ proton
 ⊖ electron

38 Each nucleus of nuclide X contains 10 protons and a total of 22 nucleons.

Which notation is correct for this nuclide?

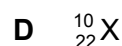
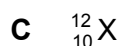
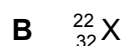
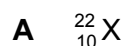

39 The diagram shows the paths of three different types of radiation X, Y and Z.

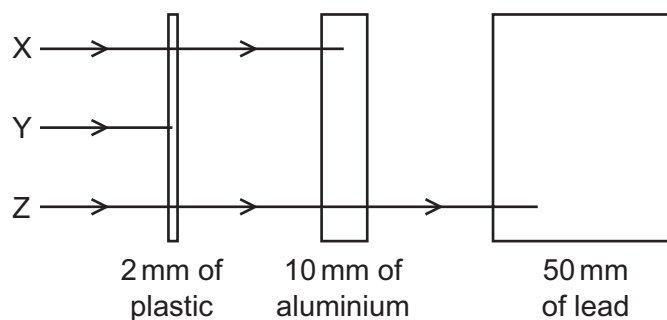

Which row correctly identifies X, Y and Z?

	X	Y	Z
A	α -particles	β -particles	γ -rays
B	β -particles	α -particles	γ -rays
C	β -particles	γ -rays	α -particles
D	γ -rays	α -particles	β -particles

40 A sample of a radioactive isotope emits 9600 α -particles per second.

After 40 hours the rate of emission has fallen to 600 α -particles per second.

What is the half-life of this isotope?

A 4.0 hours

B 8.0 hours

C 10 hours

D 20 hours

Permission to reproduce items where third-party owned material protected by copyright is included has been sought and cleared where possible. Every reasonable effort has been made by the publisher (UCLES) to trace copyright holders, but if any items requiring clearance have unwittingly been included, the publisher will be pleased to make amends at the earliest possible opportunity.

To avoid the issue of disclosure of answer-related information to candidates, all copyright acknowledgements are reproduced online in the Cambridge International Examinations Copyright Acknowledgements Booklet. This is produced for each series of examinations and is freely available to download at www.cie.org.uk after the live examination series.

Cambridge International Examinations is part of the Cambridge Assessment Group. Cambridge Assessment is the brand name of University of Cambridge Local Examinations Syndicate (UCLES), which is itself a department of the University of Cambridge.