



UNIVERSITY OF CAMBRIDGE INTERNATIONAL EXAMINATIONS  
International General Certificate of Secondary Education

**PHYSICS**

**0625/11**

Paper 1 Multiple Choice

**October/November 2012**

**45 minutes**

Additional Materials: Multiple Choice Answer Sheet  
Soft clean eraser  
Soft pencil (type B or HB recommended)

\* 8 9 1 3 2 5 1 8 2 6 \*

**READ THESE INSTRUCTIONS FIRST**

Write in soft pencil.

Do not use staples, paper clips, highlighters, glue or correction fluid.

Write your name, Centre number and candidate number on the Answer Sheet in the spaces provided unless this has been done for you.

There are **forty** questions on this paper. Answer **all** questions. For each question there are four possible answers **A, B, C** and **D**.

Choose the **one** you consider correct and record your choice in **soft pencil** on the separate Answer Sheet.

**Read the instructions on the Answer Sheet very carefully.**

Each correct answer will score one mark. A mark will not be deducted for a wrong answer.  
Any rough working should be done in this booklet.

bestexamhelp.com

This document consists of **18** printed pages and **2** blank pages.



- 1 A pendulum is set in motion and timed. The time measured for 20 complete swings is 30 s.

What is the time for one complete swing of the pendulum?

- A** 0.67 s      **B** 0.75 s      **C** 1.5 s      **D** 3.0 s

- 2 Two stones of different weight fall at the same time from a table. Air resistance may be ignored.

What will happen and why?

	what will happen	why
<b>A</b>	both stones hit the floor at the same time	acceleration of free fall is constant
<b>B</b>	both stones hit the floor at the same time	they fall at constant speed
<b>C</b>	the heavier stone hits the floor first	acceleration increases with weight
<b>D</b>	the heavier stone hits the floor first	speed increases with weight

- 3 The speed-time graph shown is for a bus travelling between stops.

Where on the graph is the acceleration of the bus greatest?

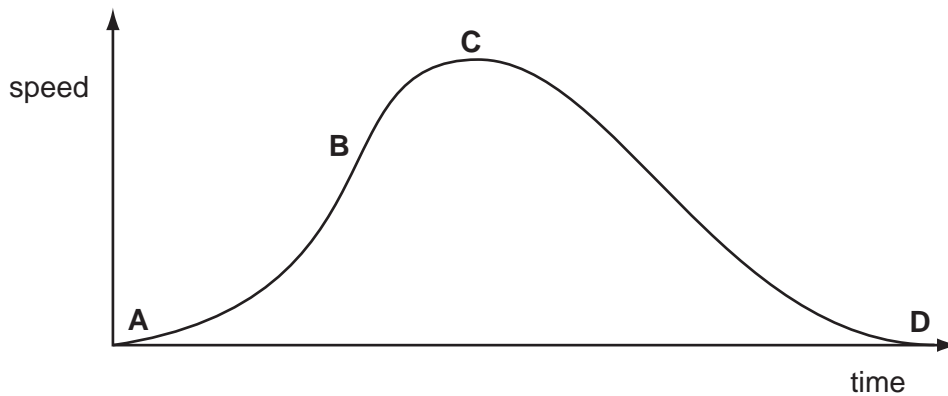

- 4 A large bag of feathers and a steel block balance each other on some scales.

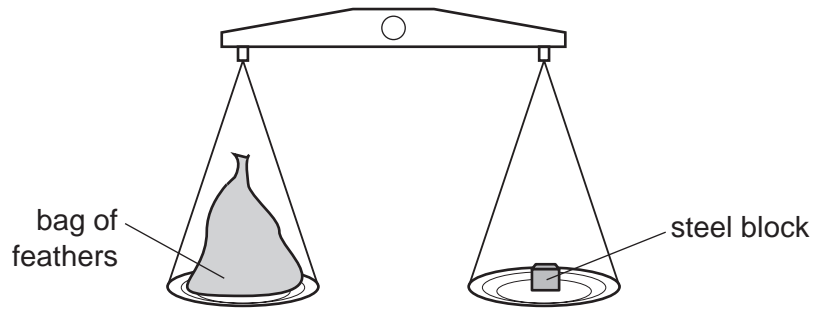

What does this show about the masses and the weights of the bag of feathers and the steel block?

- A It shows that the masses are equal and the weights are equal.
  - B It shows that the masses are equal, but the weights might be different.
  - C It shows that the masses might be different and the weights might be different.
  - D It shows that the weights are equal, but the masses might be different.
- 5 A parachutist inside an aeroplane has a mass of 70 kg.

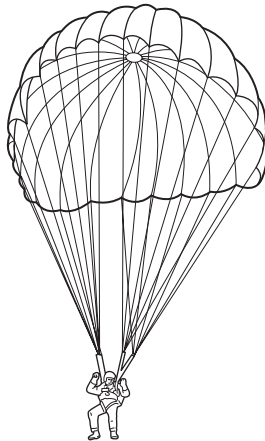

What is his mass after he has jumped from the aeroplane?

- A 0 kg
- B between 0 kg and 70 kg
- C 70 kg
- D greater than 70 kg

- 6 A liquid has a density of  $0.80 \text{ g/cm}^3$ .

Which could be the volume and mass of this liquid?

	volume/ $\text{cm}^3$	mass/g
<b>A</b>	2.0	16
<b>B</b>	8.0	10
<b>C</b>	10	8.0
<b>D</b>	16	2.0

- 7 The diagram shows sections of four objects of equal mass. The position of the centre of mass of each object has been marked with a cross.

Which object is the most stable?

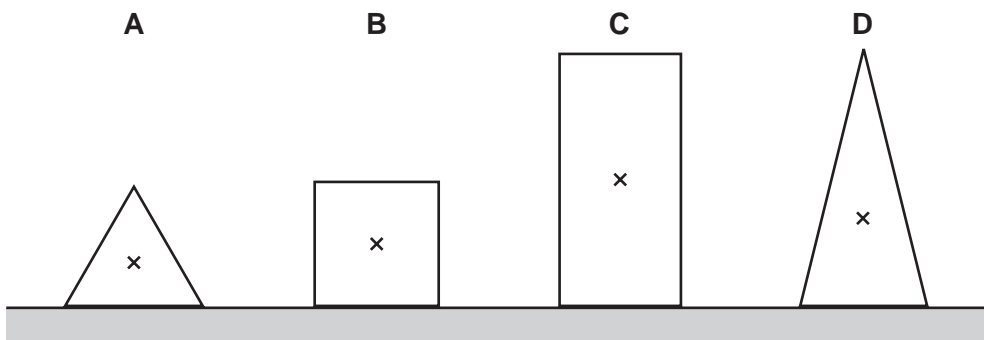

- 8 A see-saw is made by resting a long plank of wood with its centre of mass on a barrel.

A boy sits on one side of the barrel and a girl sits on the other side so that the see-saw is balanced.

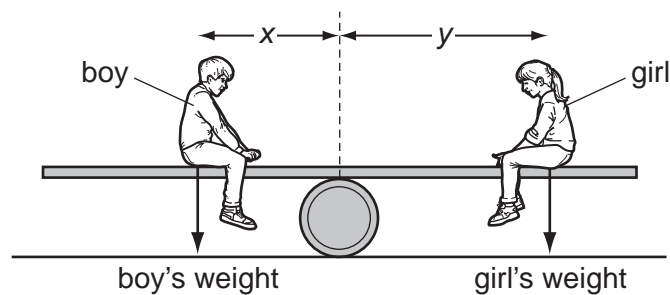

Which statement **must** be true?

- A** boy's weight = girl's weight
- B** distance  $x$  = distance  $y$
- C** total downward force = total moment about the barrel
- D** resultant force and resultant moment are both zero

- 9 A power station uses nuclear fission to obtain energy.

In this process, nuclear energy is **first** changed into

- A chemical energy.
  - B electrical energy.
  - C gravitational energy.
  - D thermal (heat) energy.
- 10 A person lifts boxes of equal weight on to a platform.

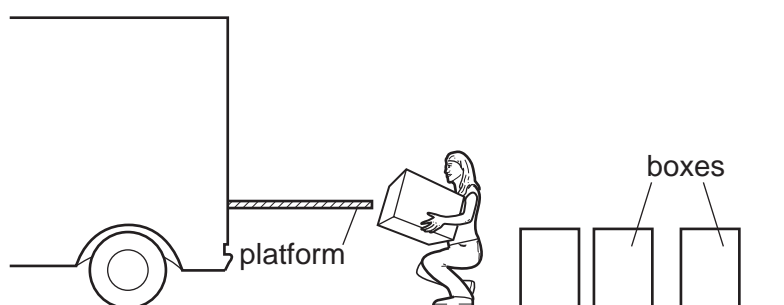

Which quantity will **not** affect the work done by the person?

- A the height of the platform above the ground
  - B the number of boxes lifted
  - C the time taken to lift the boxes
  - D the weight of the boxes
- 11 A skier walks from the bottom of a ski slope to the top and gains 10 000 J of gravitational potential energy.

She skis down the slope. At the bottom of the slope, her kinetic energy is 2000 J.

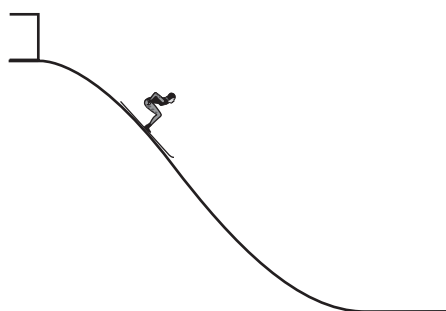

How much energy was converted into thermal energy and sound energy as the skier moved down the slope?

- A 2000 J
- B 8000 J
- C 10 000 J
- D 12 000 J

12 The diagram shows a mercury barometer.

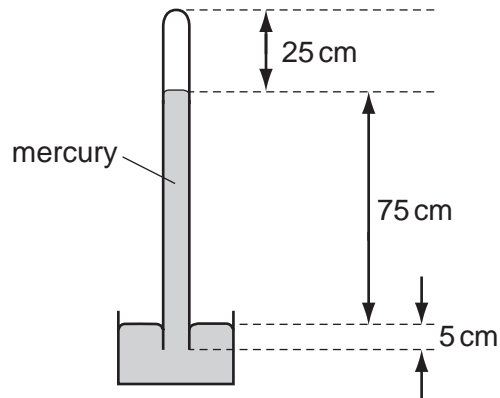

Which distance is used to calculate the pressure of the atmosphere?

- A** 25 cm      **B** 75 cm      **C** 80 cm      **D** 100 cm

13 A heavy table has six legs. The area of cross-section of each leg is  $X$ .

The legs of the table make marks in a carpet. These marks become deeper with increased pressure.

What would reduce the depth of the marks for a table of a fixed weight?

- A** using three legs, each of an area smaller than  $X$   
**B** using four legs, each of an area the same as  $X$   
**C** using six legs, each of an area smaller than  $X$   
**D** using eight legs, each of an area the same as  $X$

- 14 Very small pollen grains are suspended in water. A bright light shines from the side.

Looking through a microscope, small specks of light are seen to be moving in a random, jerky manner.

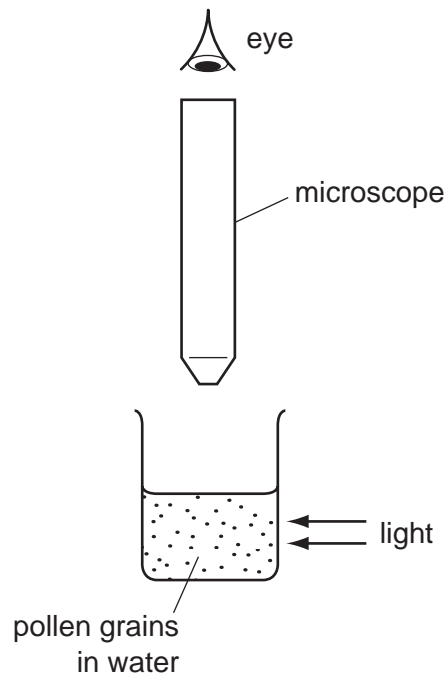

What are the moving specks of light?

- A pollen grains being hit by other pollen grains
  - B pollen grains being hit by water molecules
  - C water molecules being hit by other water molecules
  - D water molecules being hit by pollen grains
- 15 A swimmer feels cold after leaving warm water on a warm, windy day.
- Why does she feel cold even though the air is warm?
- A The less energetic water molecules on her skin escape quickly.
  - B The more energetic water molecules on her skin do not escape quickly.
  - C The water on her skin does not evaporate quickly enough to keep her warm.
  - D The water on her skin evaporates quickly and cools her skin.
- 16 Which physical property is used to measure temperature in a liquid-in-glass thermometer?
- A the length of the thermometer
  - B the thickness of the glass bulb
  - C the volume of the glass bulb
  - D the volume of the liquid

17 The graph shows the temperature of a substance as it is heated steadily.

In which part of the graph is the substance boiling?

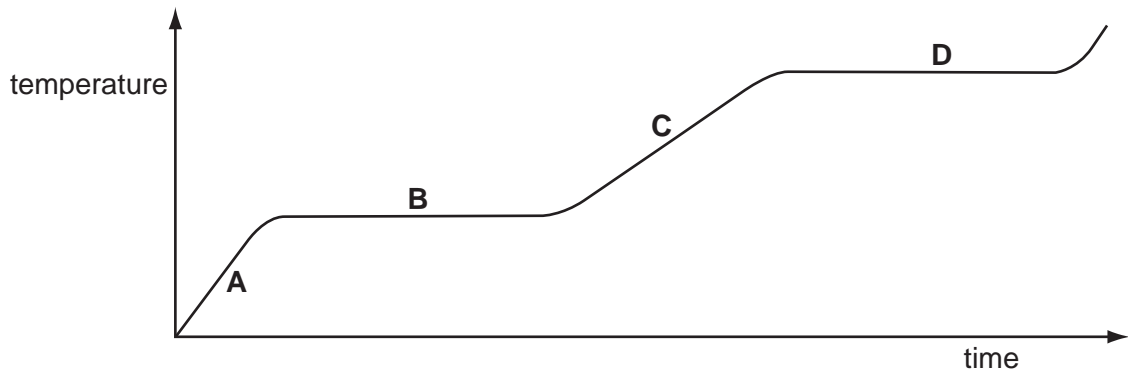

18 A night storage heater contains a large block of material that is heated electrically during the night. During the day the block cools down, releasing thermal energy into the room.

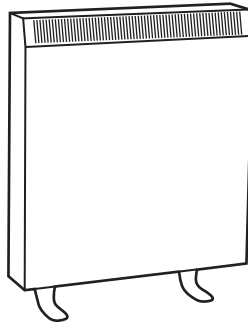

Which thermal capacity and which night-time temperature increase will cause the most energy to be stored by the block?

	thermal capacity of block	night-time temperature increase
<b>A</b>	large	large
<b>B</b>	large	small
<b>C</b>	small	large
<b>D</b>	small	small

19 After a sheep has its wool cut off, it is harder for it to stay warm when the air temperature falls.

How does the wool help the sheep to stay warm?

- A** Air can circulate between the wool fibres and heat up the skin by convection.
- B** Air trapped by the wool fibres reduces heat losses from the skin by convection.
- C** The wool fibres are curly so it takes longer for heat to be conducted away from the skin.
- D** The wool fibres conduct heat to the skin from the air outside.



- 20 A boy sits near a campfire. He pokes the fire with an iron bar. His hand becomes hot.

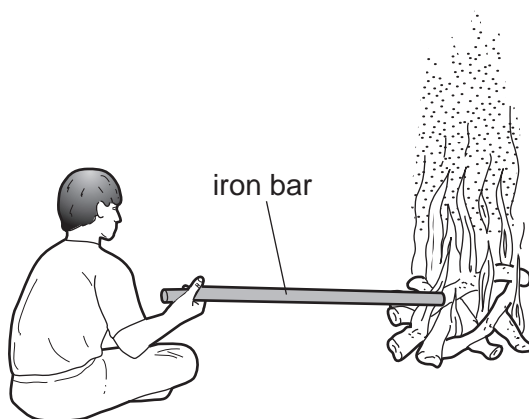

In which ways does thermal energy (heat) from the fire reach his hand?

- A conduction and convection only
  - B conduction and radiation only
  - C convection and radiation only
  - D conduction, convection and radiation
- 21 The diagram shows plane waves reflected by a plane surface.

Which line represents a wavefront?

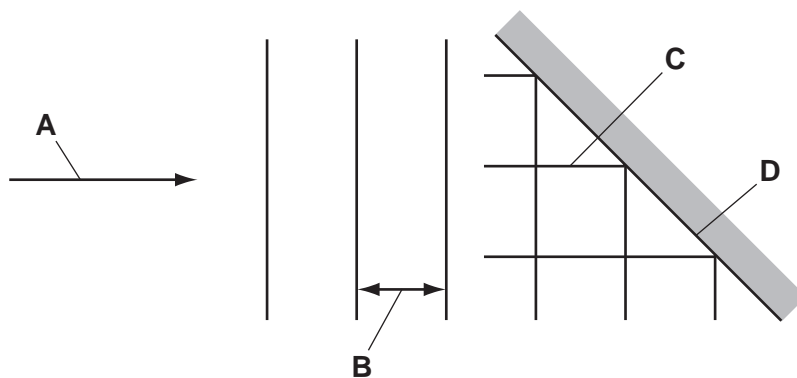

- 22 A swimmer is sitting on a rock at the sea shore looking at passing waves. He notices that five complete wavelengths pass him in 20 s.

What is the frequency of this wave?

- A 0.25 Hz
- B 4.0 Hz
- C 15 Hz
- D 100 Hz

23 A thin converging lens forms an image.

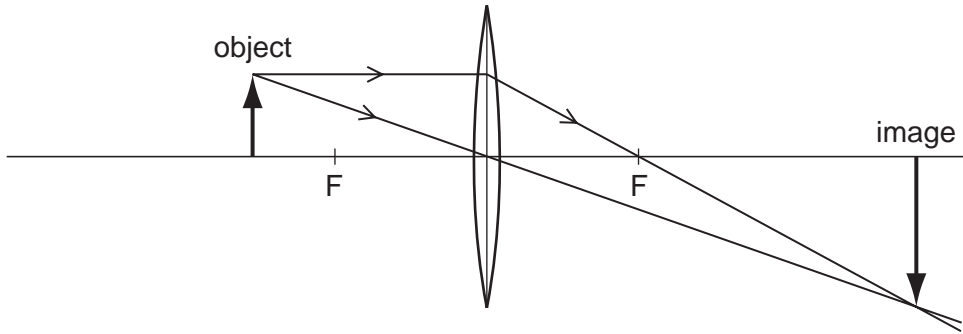

What is the nature of this image and can it be formed on a screen?

	nature of image	can be formed on a screen?
<b>A</b>	not real	no
<b>B</b>	not real	yes
<b>C</b>	real	no
<b>D</b>	real	yes

24 A piece of paper has 'PAL' written on it.

A student holds the paper in front of a plane mirror.

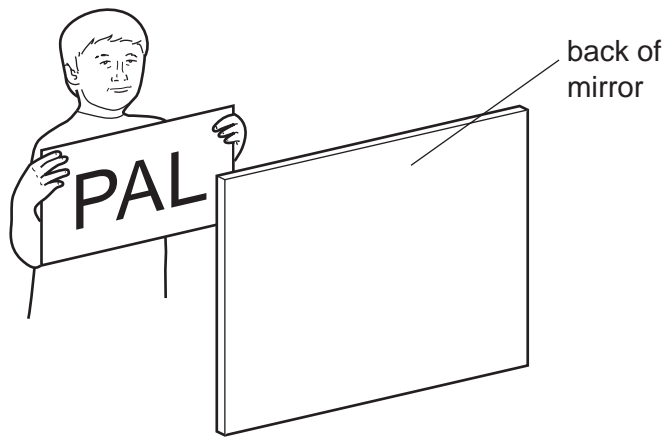

What does the student see?

A
B
C
D

PAL

LAP

PAL

LAP

25 A girl notices that when she shouts into a cave she hears an echo.

Which wave property causes the echo?

- A diffraction
- B dispersion
- C reflection
- D refraction

26 In a test, a car horn is found to be too loud and the pitch of the note is too high.

What information does this give about the amplitude and the frequency of the sound wave produced?

	amplitude	frequency
<b>A</b>	too large	too large
<b>B</b>	too large	too small
<b>C</b>	too small	too large
<b>D</b>	too small	too small

27 Two bars of soft iron are placed near a bar magnet.

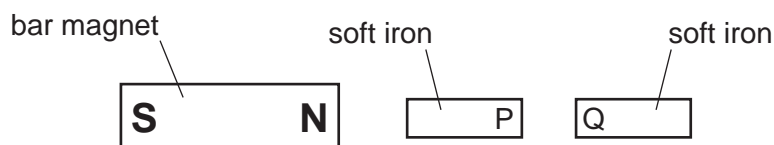

Which row states and explains the behaviour of poles P and Q of the soft iron bars?

	P and Q	reason
<b>A</b>	attract	P and Q are like poles
<b>B</b>	attract	P and Q are unlike poles
<b>C</b>	repel	P and Q are like poles
<b>D</b>	repel	P and Q are unlike poles

- 28 Some electrical devices require a magnet which may be switched on and off many times in a second.

Which type of magnet may be used?

- A an electromagnet only  
 B a permanent magnet only  
 C either a permanent magnet or an electromagnet  
 D neither a permanent magnet nor an electromagnet
- 29 Which of these is an electric current?
- A a beam of atoms  
 B a beam of electrons  
 C a beam of molecules  
 D a beam of neutrons
- 30 The diagram shows a circuit used to find the resistance of lamp L.

Blocks P, Q and R represent the different components used.

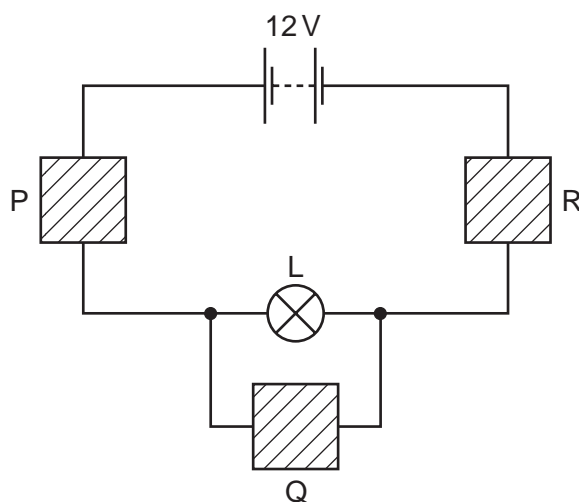

Which is a correct possible choice of components to use for P, Q and R?

	P	Q	R
<b>A</b>	ammeter	variable resistor	voltmeter
<b>B</b>	variable resistor	voltmeter	ammeter
<b>C</b>	voltmeter	ammeter	variable resistor
<b>D</b>	voltmeter	variable resistor	ammeter

31 A student connects the circuit shown.

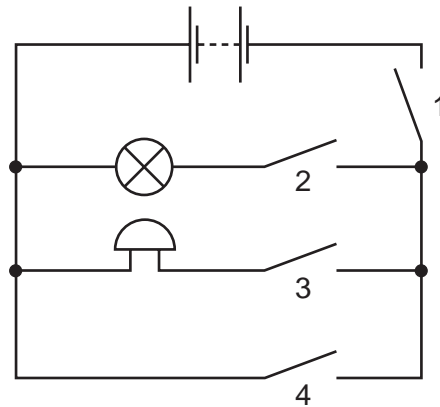

Which switches must be closed for the bell to ring without lighting the lamp?

- A 1 and 2 only
- B 1 and 3 only
- C 1, 3 and 4 only
- D 2, 3 and 4 only

32 Which row shows a use of a capacitor and a use of a relay?

	use of a capacitor	use of a relay
<b>A</b>	switching circuit	voltage transformation
<b>B</b>	time-delay circuit	switching circuit
<b>C</b>	voltage transformation	switching circuit
<b>D</b>	voltage transformation	time-delay circuit

- 33 The diagram shows two voltmeters, P and Q, connected to a potential divider.

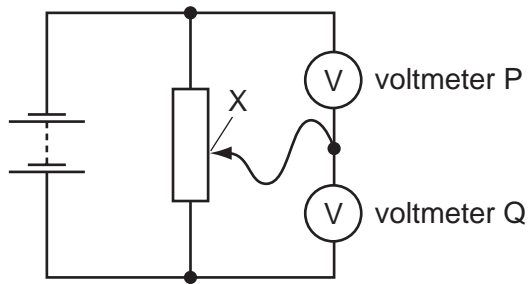

The sliding connection at point X is moved towards the top of the diagram.

What happens to the reading on P and to the reading on Q?

	reading on P	reading on Q
<b>A</b>	decreases	decreases
<b>B</b>	decreases	increases
<b>C</b>	increases	decreases
<b>D</b>	increases	increases

- 34 An electric oven is connected to the mains supply using insulated copper wires. The wires become very warm.

What can be done to prevent so much heat being produced in the connecting wires?

- A** Use thicker copper wires.
- B** Use thinner copper wires.
- C** Use thicker insulation.
- D** Use thinner insulation.

35 Which graph shows how the voltage of a simple a.c. generator varies with time?

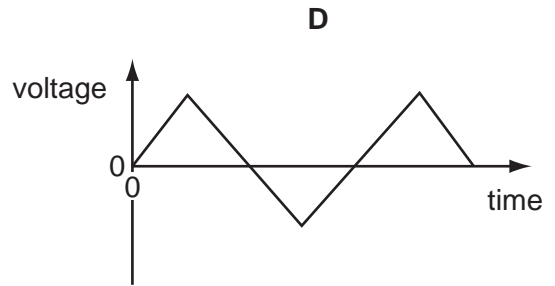
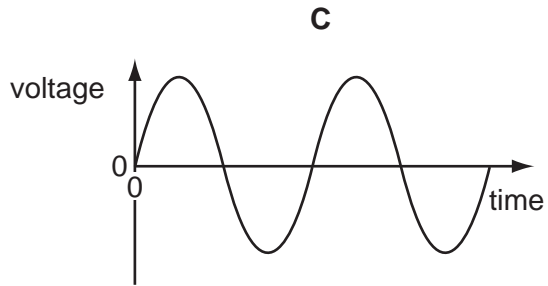
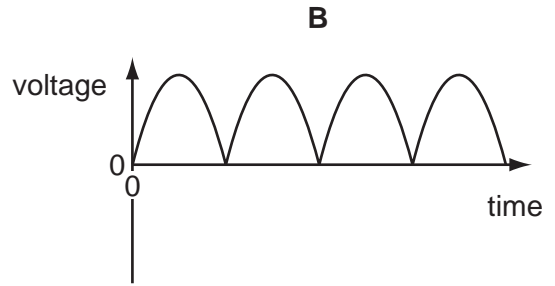
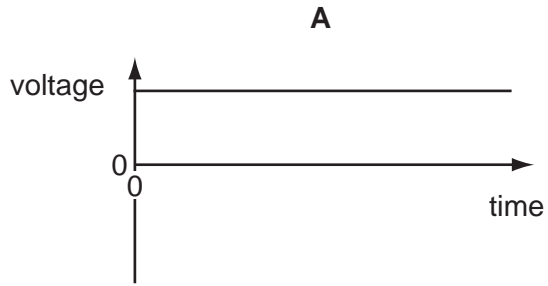

36 The diagram shows a wire in the magnetic field between two poles of a magnet.

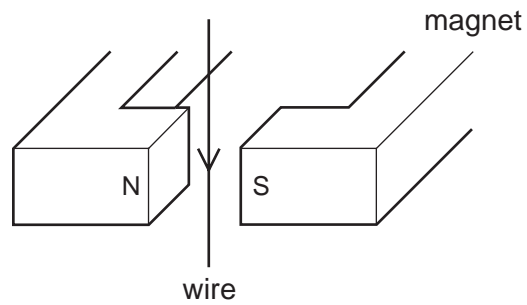

The current in the wire repeatedly changes between a constant value in one direction and a constant value in the opposite direction. This is shown on the graph.

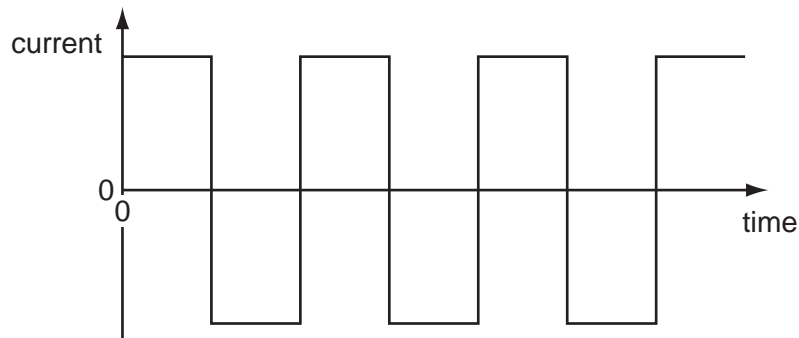

What is the effect on the wire?

- A** The force on the wire alternates between one direction and the opposite direction.
- B** The force on the wire is constant in size and direction.
- C** There is no force acting on the wire at any time.
- D** There is only a force on the wire when the current reverses.



- 37 A beam of cathode rays passes between two parallel, charged metal plates in a vacuum.

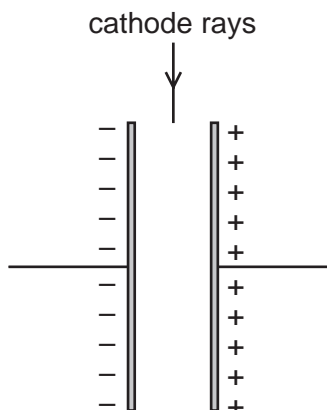

In which direction is the beam deflected?

- A** into the page  
**B** out of the page  
**C** to the left of the page  
**D** to the right of the page
- 38 How does the ionising effect of  $\alpha$ -particles compare with that of  $\beta$ -particles and  $\gamma$ -rays?

	compared with $\beta$ -particles	compared with $\gamma$ -rays
<b>A</b>	$\alpha$ -particles are less strongly ionising	$\alpha$ -particles are less strongly ionising
<b>B</b>	$\alpha$ -particles are less strongly ionising	$\alpha$ -particles are more strongly ionising
<b>C</b>	$\alpha$ -particles are more strongly ionising	$\alpha$ -particles are less strongly ionising
<b>D</b>	$\alpha$ -particles are more strongly ionising	$\alpha$ -particles are more strongly ionising

- 39 The table shows the count rates obtained from four radioactive sources. The measurements were taken at noon on four consecutive days.

Which source has the longest half-life?

	count rate / counts per second			
	day 1	day 2	day 3	day 4
<b>A</b>	100	48	27	11
<b>B</b>	200	142	99	69
<b>C</b>	300	297	292	290
<b>D</b>	400	202	99	48

40 Which statement about a carbon nucleus represented by  ${}^{14}_6\text{C}$  is correct?

- A It contains 6 neutrons.
- B It contains 6 electrons.
- C It contains 8 protons.
- D It contains 14 nucleons.



**BLANK PAGE**

---

Permission to reproduce items where third-party owned material protected by copyright is included has been sought and cleared where possible. Every reasonable effort has been made by the publisher (UCLES) to trace copyright holders, but if any items requiring clearance have unwittingly been included, the publisher will be pleased to make amends at the earliest possible opportunity.

University of Cambridge International Examinations is part of the Cambridge Assessment Group. Cambridge Assessment is the brand name of University of Cambridge Local Examinations Syndicate (UCLES), which is itself a department of the University of Cambridge.