



UNIVERSITY OF CAMBRIDGE INTERNATIONAL EXAMINATIONS  
International General Certificate of Secondary Education

CANDIDATE  
NAME

CENTRE  
NUMBER

--	--	--	--	--

CANDIDATE  
NUMBER

--	--	--	--



**MATHEMATICS**

**0580/41**

Paper 4 (Extended)

**October/November 2011**

**2 hours 30 minutes**

Candidates answer on the Question Paper.

Additional Materials:

Electronic calculator

Mathematical tables (optional)

Geometrical instruments

Tracing paper (optional)

**READ THESE INSTRUCTIONS FIRST**

Write your Centre number, candidate number and name on all the work you hand in.

Write in dark blue or black pen.

You may use a pencil for any diagrams or graphs.

Do not use staples, paper clips, highlighters, glue or correction fluid.

**DO NOT WRITE IN ANY BARCODES.**

Answer **all** questions.

If working is needed for any question it must be shown below that question.

Electronic calculators should be used.

If the degree of accuracy is not specified in the question, and if the answer is not exact, give the answer to three significant figures. Give answers in degrees to one decimal place.

For  $\pi$  use either your calculator value or 3.142.

At the end of the examination, fasten all your work securely together.

The number of marks is given in brackets [ ] at the end of each question or part question.

The total of the marks for this paper is 130.

This document consists of **16** printed pages.



- 1 (a) Abdullah and Jasmine bought a car for \$9000.  
Abdullah paid 45% of the \$9000 and Jasmine paid the rest.

(i) How much did Jasmine pay towards the cost of the car?

Answer(a)(i) \$ ..... [2]

(ii) Write down the ratio of the payments Abdullah : Jasmine in its simplest form.

Answer(a)(ii) ..... : ..... [1]

- (b) Last year it cost \$2256 to run the car.  
Abdullah, Jasmine and their son Henri share this cost in the ratio 8 : 3 : 1.  
Calculate the amount each paid to run the car.

Answer(b) Abdullah \$ .....

Jasmine \$ .....

Henri \$ ..... [3]

- (c) (i) A new truck costs \$15 000 and loses 23% of its value **each year**.  
Calculate the value of the truck after three years.

Answer(c)(i) \$ ..... [3]

(ii) Calculate the overall percentage loss of the truck's value after three years.

Answer(c)(ii) ..... % [3]

- 2 (a) Find the integer values for  $x$  which satisfy the inequality  $-3 < 2x - 1 \leq 6$ .

For  
Examiner's  
Use

Answer(a) ..... [3]

- (b) Simplify  $\frac{x^2 + 3x - 10}{x^2 - 25}$ .

Answer(b) ..... [4]

- (c) (i) Show that  $\frac{5}{x-3} + \frac{2}{x+1} = 3$  can be simplified to  $3x^2 - 13x - 8 = 0$ .

Answer(c)(i)

[3]

- (ii) Solve the equation  $3x^2 - 13x - 8 = 0$ .

Show all your working and give your answers correct to two decimal places.

Answer(c)(ii)  $x =$  ..... or  $x =$  ..... [4]

- 3 The table shows information about the heights of 120 girls in a swimming club.

Height ( $h$ metres)	Frequency
$1.3 < h \leq 1.4$	4
$1.4 < h \leq 1.5$	13
$1.5 < h \leq 1.6$	33
$1.6 < h \leq 1.7$	45
$1.7 < h \leq 1.8$	19
$1.8 < h \leq 1.9$	6

For  
Examiner's  
Use

- (a) (i) Write down the modal class.

Answer(a)(i) ..... m [1]

- (ii) Calculate an estimate of the mean height. Show all of your working.

Answer(a)(ii) ..... m [4]

- (b) Girls from this swimming club are chosen at random to swim in a race.  
Calculate the probability that

- (i) the height of the first girl chosen is more than 1.8 metres,

Answer(b)(i) ..... [1]

- (ii) the heights of **both** the first and second girl chosen are 1.8 metres or less.

Answer(b)(ii) ..... [3]

(c) (i) Complete the cumulative frequency table for the heights.

Height ( $h$ metres)	Cumulative frequency
$h \leq 1.3$	0
$h \leq 1.4$	4
$h \leq 1.5$	17
$h \leq 1.6$	50
$h \leq 1.7$	
$h \leq 1.8$	114
$h \leq 1.9$	

[1]

(ii) Draw the cumulative frequency graph on the grid.

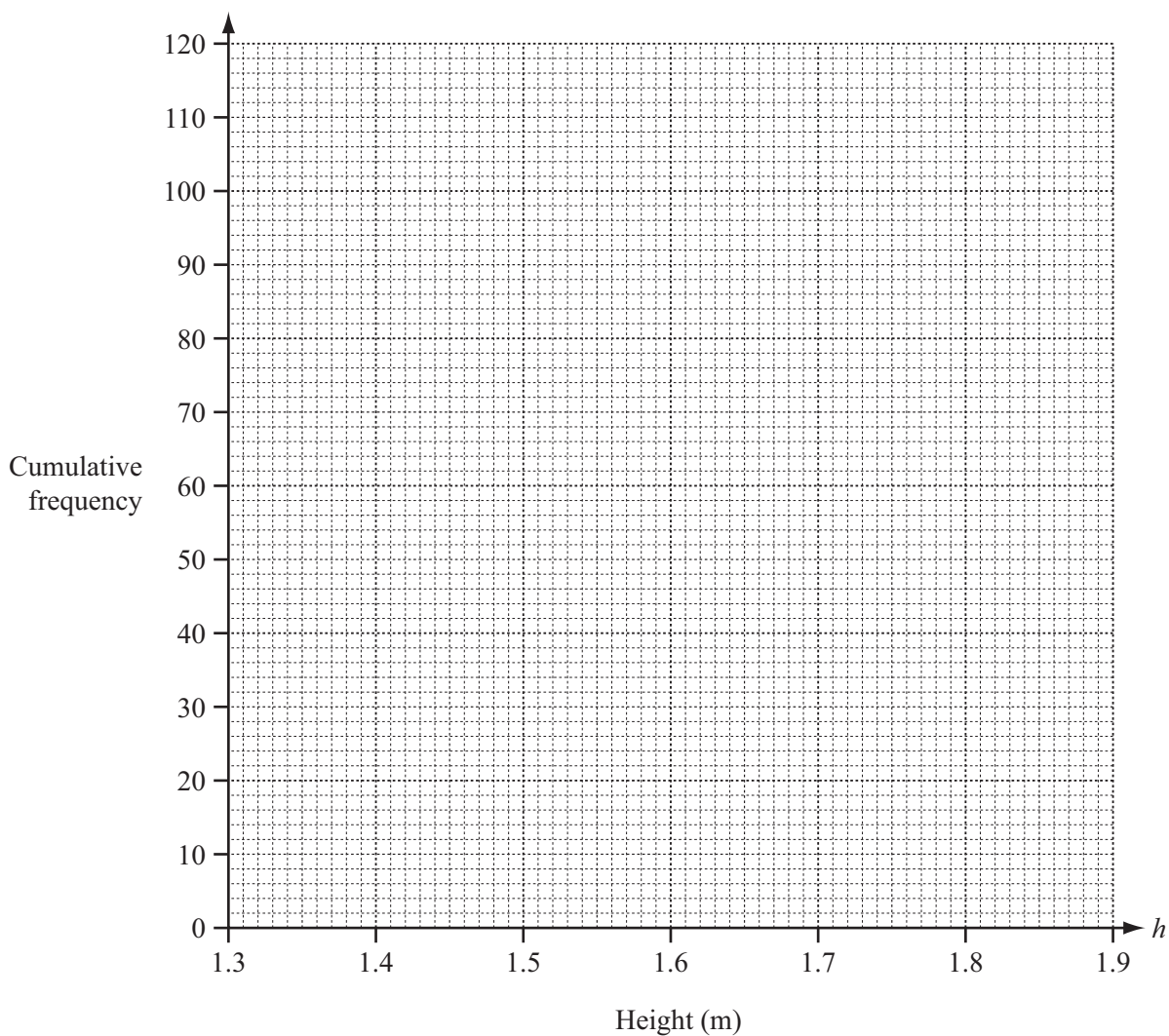

[3]

(d) Use your graph to find

(i) the median height,

Answer(d)(i) ..... m [1]

(ii) the 30th percentile.

Answer(d)(ii) ..... m [1]

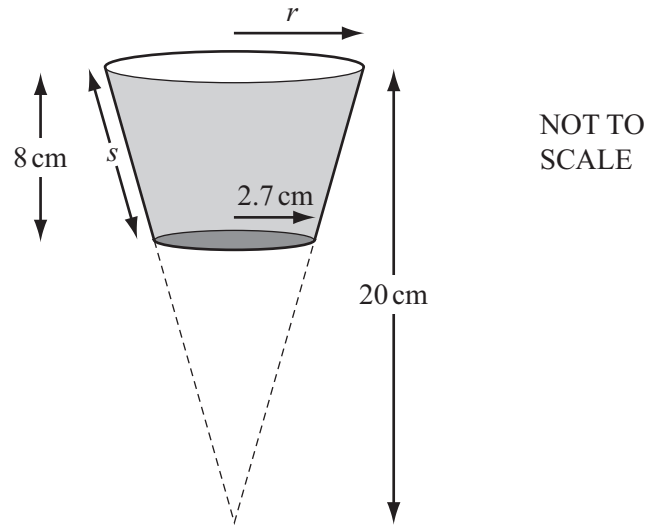

The diagram shows a plastic cup in the shape of a cone with the end removed.  
 The vertical height of the cone in the diagram is 20 cm.  
 The height of the cup is 8 cm.  
 The base of the cup has radius 2.7 cm.

- (a) (i) Show that the radius,  $r$ , of the circular top of the cup is 4.5 cm.

*Answer(a)(i)*

[2]

- (ii) Calculate the volume of water in the cup when it is full.

[The volume,  $V$ , of a cone with radius  $r$  and height  $h$  is  $V = \frac{1}{3} \pi r^2 h$ .]

*Answer(a)(ii)* .....  $\text{cm}^3$  [4]

- (b) (i) Show that the slant height,  $s$ , of the cup is 8.2 cm.

*Answer(b)(i)*

*For  
Examiner's  
Use*

[3]

- (ii) Calculate the curved surface area of the outside of the cup.  
[The curved surface area,  $A$ , of a cone with radius  $r$  and slant height  $l$  is  $A = \pi rl$ .]

*Answer(b)(ii)* ..... cm<sup>2</sup> [5]

---

- 5 (a) Complete the table for the function  $f(x) = \frac{x^3}{2} - 3x - 1$ .

For  
Examiner's  
Use

$x$	-3	-2	-1.5	-1	0	1	1.5	2	3	3.5
$f(x)$	-5.5		1.8	1.5		-3.5	-3.8	-3		9.9

[3]

- (b) On the grid draw the graph of  $y = f(x)$  for  $-3 \leq x \leq 3.5$ .

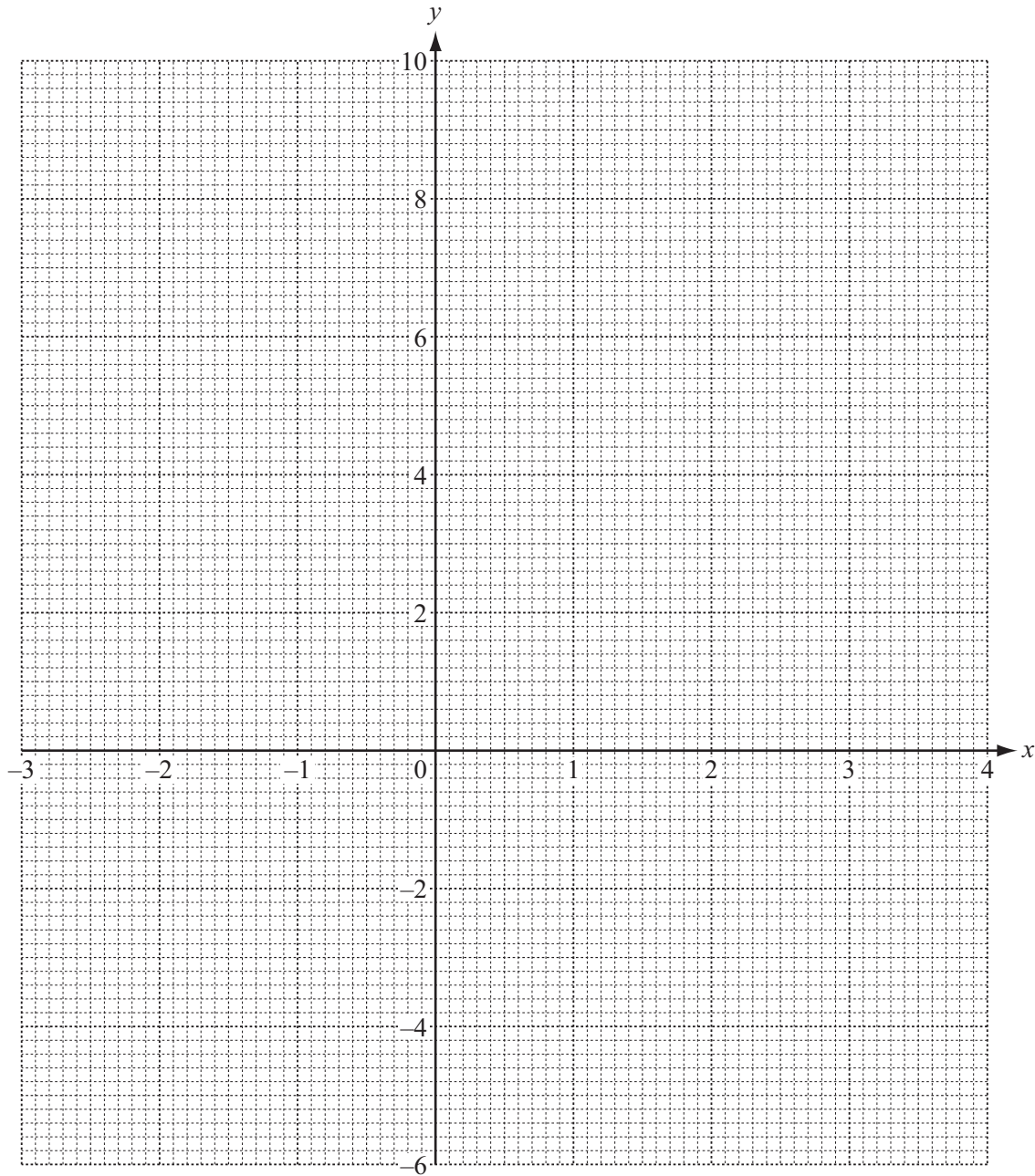

[4]



(c) Use your graph to

(i) solve  $f(x) = 0.5$ ,

Answer(c)(i)  $x = \dots\dots\dots$  or  $x = \dots\dots\dots$  or  $x = \dots\dots\dots$  [3]

(ii) find the inequalities for  $k$ , so that  $f(x) = k$  has only 1 answer.

Answer(c)(ii)  $k < \dots\dots\dots$   
 $k > \dots\dots\dots$  [2]

(d) (i) On the same grid, draw the graph of  $y = 3x - 2$  for  $-1 \leq x \leq 3.5$ . [3]

(ii) The equation  $\frac{x^3}{2} - 3x - 1 = 3x - 2$  can be written in the form  $x^3 + ax + b = 0$ .  
 Find the values of  $a$  and  $b$ .

Answer(d)(ii)  $a = \dots\dots\dots$  and  $b = \dots\dots\dots$  [2]

(iii) Use your graph to find the **positive** answers to  $\frac{x^3}{2} - 3x - 1 = 3x - 2$  for  $-3 \leq x \leq 3.5$ .

Answer(d)(iii)  $x = \dots\dots\dots$  or  $x = \dots\dots\dots$  [2]

6

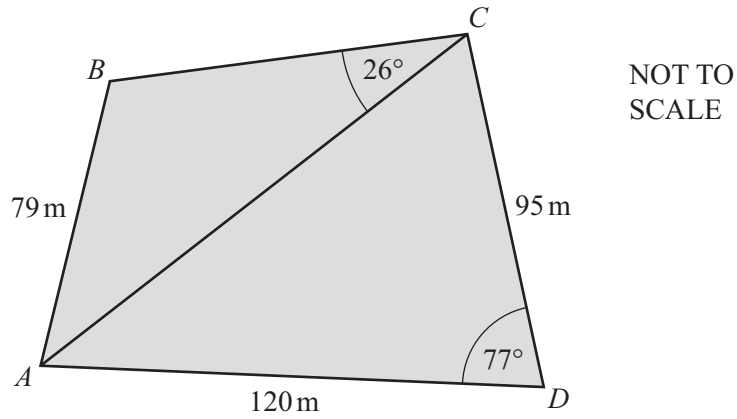

For  
Examiner's  
Use

The quadrilateral  $ABCD$  represents an area of land.  
There is a straight road from  $A$  to  $C$ .  
 $AB = 79$  m,  $AD = 120$  m and  $CD = 95$  m.  
Angle  $BCA = 26^\circ$  and angle  $CDA = 77^\circ$ .

(a) Show that the length of the road,  $AC$ , is 135 m correct to the nearest metre.

*Answer(a)*

[4]

(b) Calculate the size of the **obtuse** angle  $ABC$ .

*Answer(b)* Angle  $ABC =$  ..... [4]

- (c) A straight path is to be built from  $B$  to the nearest point on the road  $AC$ .

Calculate the length of this path.

For  
Examiner's  
Use

*Answer(c)* ..... m [3]

- (d) Houses are to be built on the land in triangle  $ACD$ .  
Each house needs at least  $180 \text{ m}^2$  of land.

Calculate the maximum number of houses which can be built.  
Show all of your working.

*Answer(d)* ..... [4]

---

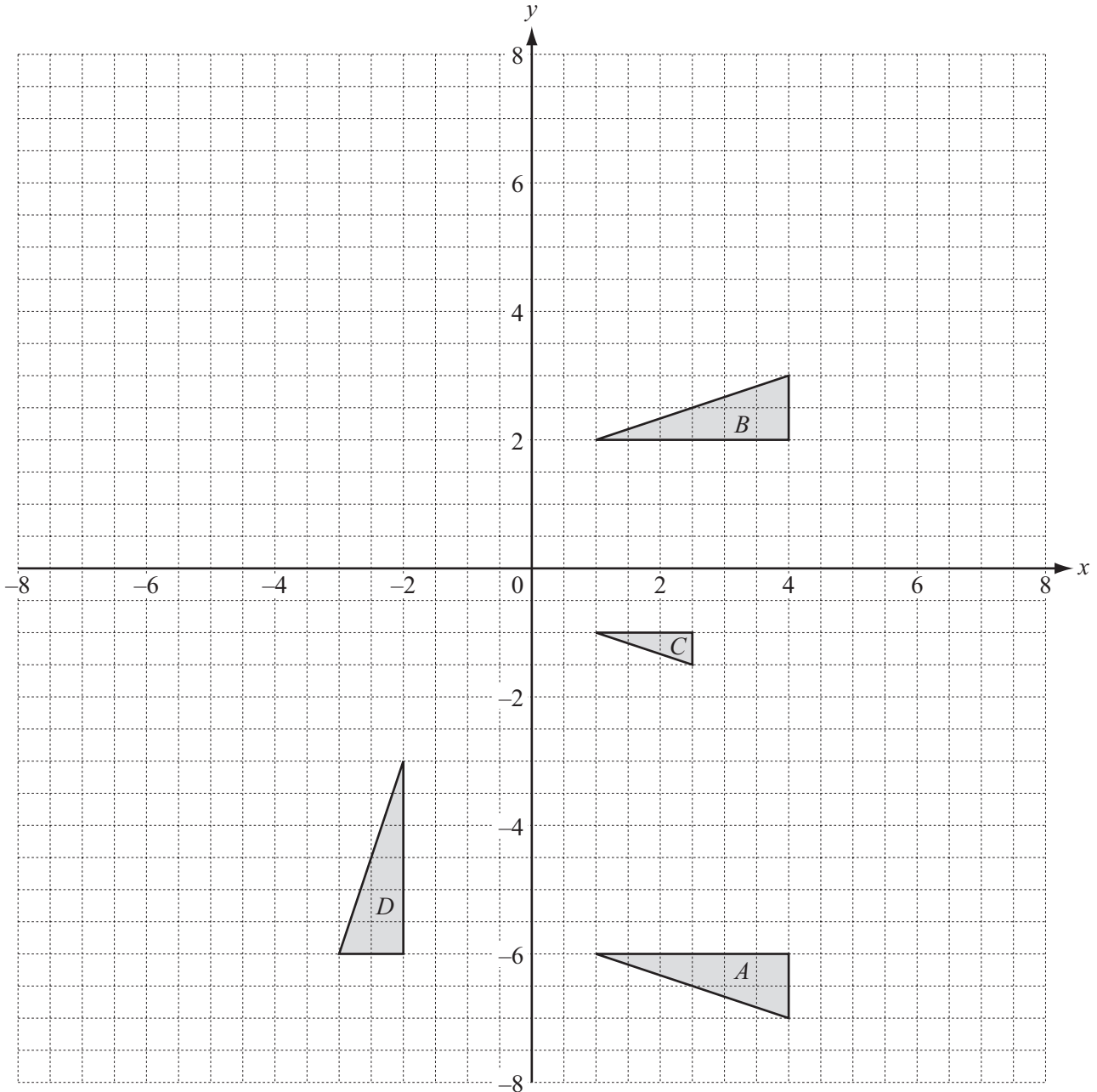

(a) Describe fully the **single** transformation which maps

(i) triangle *A* onto triangle *B*,

Answer(a)(i) ..... [2]

(ii) triangle *A* onto triangle *C*,

Answer(a)(ii) ..... [3]

(iii) triangle *A* onto triangle *D*.

Answer(a)(iii) ..... [3]

(b) Draw the image of

(i) triangle  $B$  after a translation of  $\begin{pmatrix} -5 \\ 2 \end{pmatrix}$ , [2]

(ii) triangle  $B$  after a transformation by the matrix  $\begin{pmatrix} 1 & 0 \\ 0 & 2 \end{pmatrix}$ . [3]

(c) Describe fully the **single** transformation represented by the matrix  $\begin{pmatrix} 1 & 0 \\ 0 & 2 \end{pmatrix}$ .

*Answer(c)* .....

..... [3]

*For  
Examiner's  
Use*

8 Mr Chang hires  $x$  large coaches and  $y$  small coaches to take 300 students on a school trip. Large coaches can carry 50 students and small coaches 30 students. There is a maximum of 5 large coaches.

For  
Examiner's  
Use

(a) Explain clearly how the following two inequalities satisfy these conditions.

(i)  $x \leq 5$

Answer(a)(i) ..... [1]

(ii)  $5x + 3y \geq 30$

Answer(a)(ii) .....  
..... [2]

Mr Chang also knows that  $x + y \leq 10$ .

(b) On the grid, show the information above by drawing three straight lines and shading the **unwanted** regions.

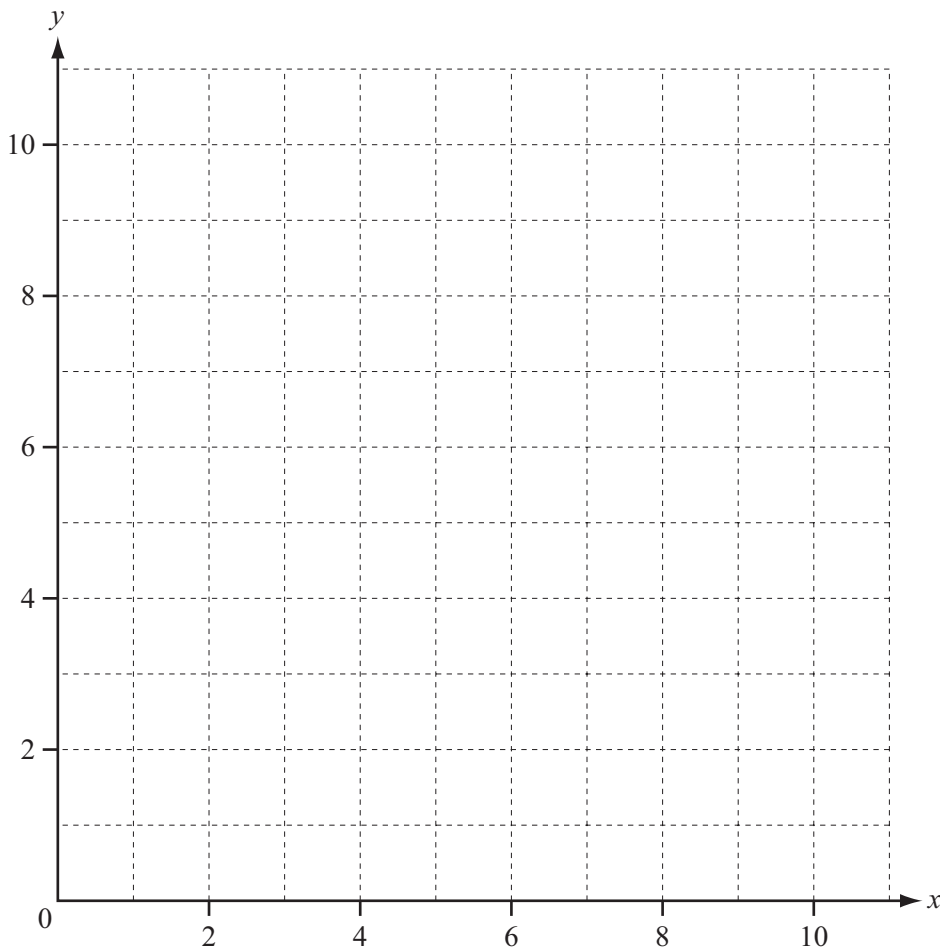

[5]

(c) A large coach costs \$450 to hire and a small coach costs \$350.

(i) Find the number of large coaches and the number of small coaches that would give the minimum hire cost for this school trip.

*Answer(c)(i)* Large coaches .....

Small coaches ..... [2]

(ii) Calculate this minimum cost.

*Answer(c)(ii)* \$ ..... [1]

9 (a)  $72 = 2 \times 2 \times 2 \times 3 \times 3$  written as a product of prime factors.

(i) Write the number 126 as a product of prime factors.

*Answer(a)(i)* 126 = ..... [2]

(ii) Find the value of the highest common factor of 72 and 126.

*Answer(a)(ii)* ..... [1]

(iii) Find the value of the lowest common multiple of 72 and 126.

*Answer(a)(iii)* ..... [2]

The rest of question 9 is printed on the next page.

For  
Examiner's  
Use

- (b) John wants to estimate the value of  $\pi$ .

He measures the circumference of a circular pizza as 105 cm and its diameter as 34 cm, both correct to the nearest centimetre.

Calculate the lower bound of his estimate of the value of  $\pi$ .

Give your answer correct to 3 decimal places.

*Answer(b)* ..... [4]

- (c) The volume of a cylindrical can is  $550 \text{ cm}^3$ , correct to the nearest  $10 \text{ cm}^3$ .  
The height of the can is 12 cm correct to the nearest centimetre.

Calculate the upper bound of the radius of the can.

Give your answer correct to 3 decimal places.

*Answer(c)* ..... cm [5]

*For  
Examiner's  
Use*