



UNIVERSITY OF CAMBRIDGE INTERNATIONAL EXAMINATIONS  
International General Certificate of Secondary Education

CANDIDATE  
NAME

CENTRE  
NUMBER

--	--	--	--	--

CANDIDATE  
NUMBER

--	--	--	--	--

\* 7 5 1 3 0 4 1 4 5 9 \*

**MATHEMATICS**

**0580/12**

Paper 1 (Core)

**May/June 2010**

**1 hour**

Candidates answer on the Question Paper.

Additional Materials:

Electronic Calculator  
Geometrical Instruments

Mathematical tables (optional)  
Tracing paper (optional)

**READ THESE INSTRUCTIONS FIRST**

Write your Centre number, candidate number and name on all the work you hand in.

Write in dark blue or black pen.

You may use a pencil for any diagrams or graphs.

Do not use staples, paper clips, highlighters, glue or correction fluid.

**DO NOT WRITE IN ANY BARCODES.**

Answer **all** questions.

If working is needed for any question it must be shown below that question.

Electronic calculators should be used.

If the degree of accuracy is not specified in the question, and if the answer is not exact, give the answer to three significant figures. Give answers in degrees to one decimal place.

For  $\pi$ , use either your calculator value or 3.142.

At the end of the examination, fasten all your work securely together.

The number of marks is given in brackets [ ] at the end of each question or part question.

The total of the marks for this paper is 56.

This document consists of **12** printed pages.



1

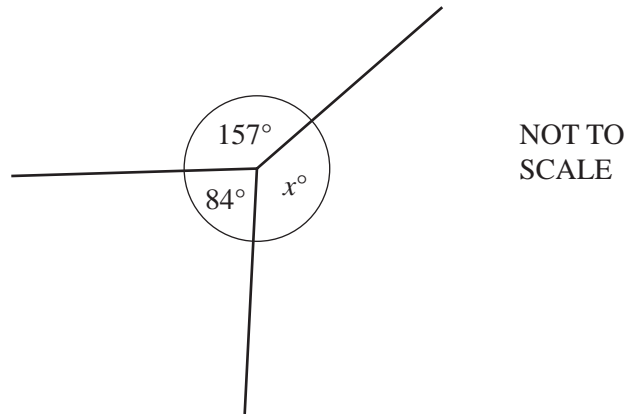

Find the value of  $x$ .

Answer  $x =$  ..... [1]

---

2 (a) Write down the smallest number which is a multiple of both 8 and 12.

Answer(a) ..... [1]

(b) Write down **all** the other multiples of both 8 and 12 which are less than 100.

Answer(b) ..... [1]

---

3 Factorise **completely**  $6mp - 9pq$ .

Answer ..... [2]

---

- 4 1 litre of apple juice is poured into 3 glasses.

The first glass contains  $\frac{2}{5}$  litre.

The second glass contains  $\frac{1}{4}$  litre.

What fraction of a litre does the third glass contain?  
Show all your working clearly.

*Answer* ..... [2]

---

- 5 A plane from Hong Kong to New Zealand leaves at 18 10 on Monday.  
The time in New Zealand is 4 hours ahead of the time in Hong Kong.

(a) Write down the time in New Zealand when the plane leaves Hong Kong.

*Answer(a)* ..... [1]

(b) The plane arrives in New Zealand at 09 45 on Tuesday.

How long, in hours and minutes, does the journey take?

*Answer(b)* ..... h ..... min [1]

---

- 6 Alphonse changed 400 Brazilian reals into South African Rand.  
The exchange rate was 1 Brazilian real = 4.76 South African Rand (R).

How much did he receive?

Answer R ..... [2]

---

- 7 Joe measured the diameter of a tennis ball correct to the nearest millimetre.  
The upper bound of his measurement was 6.75 centimetres.

Write down, **in millimetres**, the lower bound of his measurement.

Answer ..... mm [2]

---

- 8 Make  $p$  the subject of the formula  $m = p^2 - 2$ .

Answer  $p =$  ..... [2]

---

9

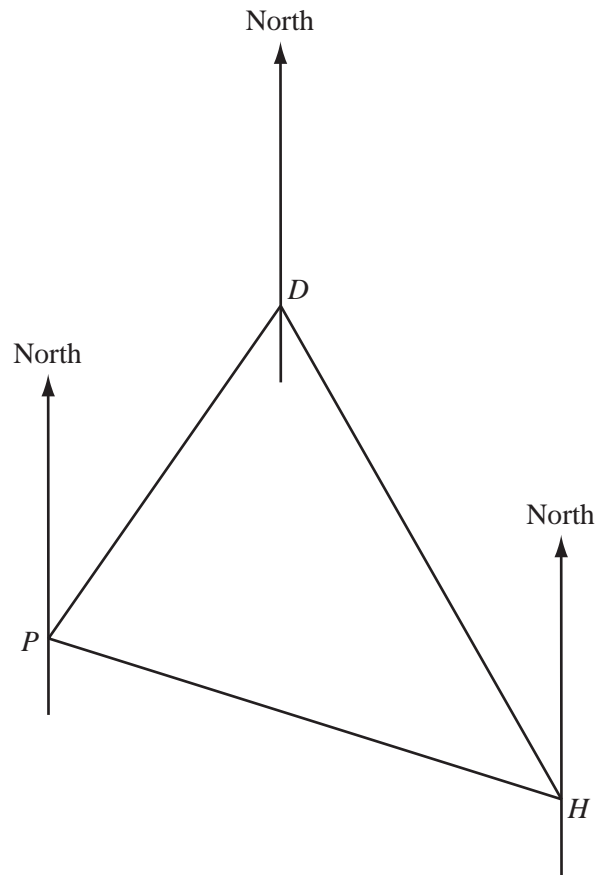

For  
Examiner's  
Use

The positions of Perth ( $P$ ), Darwin ( $D$ ) and Hobart ( $H$ ) are shown on the diagram.

Measure accurately any angles you need and write down the bearing of

(a)  $D$  from  $P$ ,

Answer(a) ..... [1]

(b)  $P$  from  $H$ .

Answer(b) ..... [1]

10 When  $c = 10$  and  $d = -2$ , find the value of the following expressions.

(a)  $c + 2d$

Answer(a) ..... [1]

(b)  $5c^2 - cd$

Answer(b) ..... [2]

- 11 Fifteen children ran a 60 metre race.  
In the scatter diagram below, the time taken is plotted against the age for each child.

For  
Examiner's  
Use

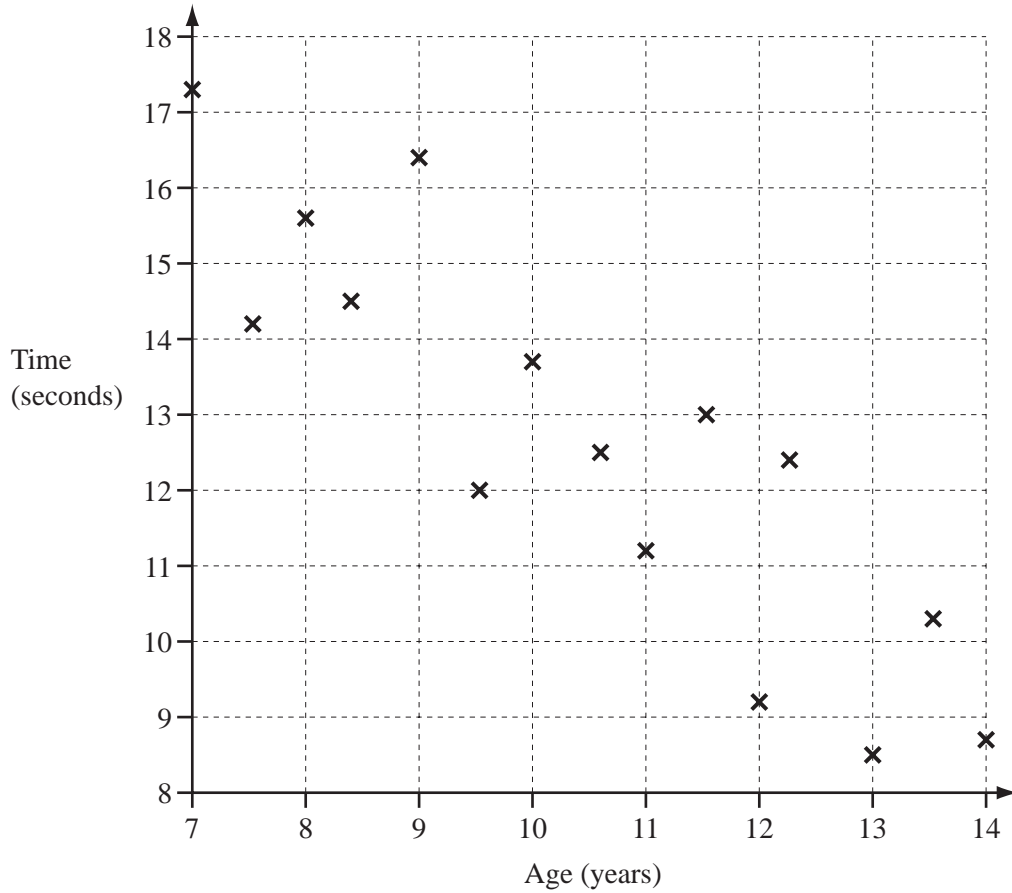

(a) Draw a line of best fit on the scatter diagram. [1]

(b) What type of correlation does the scatter diagram show?

Answer(b) ..... [1]

(c) Describe how the times taken change with the ages of the children.

Answer (c) ..... [1]

12 (a)  $\frac{1}{27} = 3^x$ .

Write down the value of  $x$ .

Answer(a)  $x =$  ..... [1]

(b) Simplify

(i)  $p^7 \times p^{-2}$ ,

Answer(b)(i) ..... [1]

(ii)  $m^3 \div m^7$ .

Answer(b)(ii) ..... [1]

13 (a) Work out  $\frac{0.68 + 2.57 \times 1.76}{63}$ .

Write down all the figures from your calculator display.

Answer(a) ..... [1]

(b) Write your answer to **part (a)** in standard form correct to 3 significant figures.

Answer(b) ..... [2]

14 Solve the simultaneous equations.

$$3x - 2y = 15$$

$$2x + y = 17$$

Answer  $x =$  .....

$y =$  ..... [3]

- 15 The diagram shows a prism.  
The lengths are in centimetres.

NOT TO  
SCALE

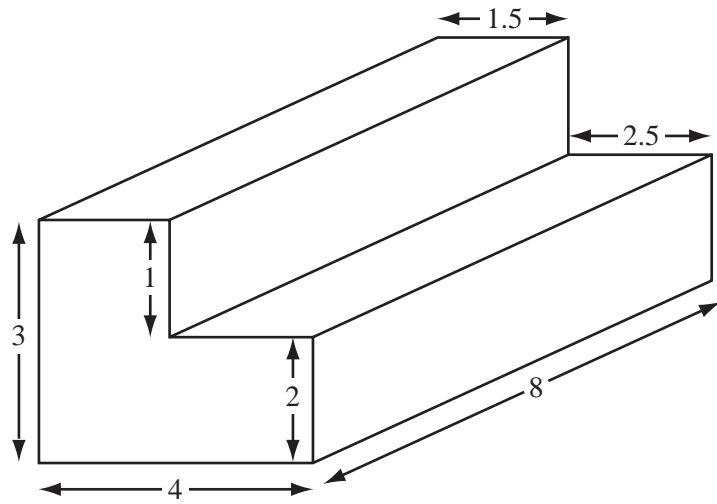

Part of an accurate net of the prism is drawn below.  
Complete the net.

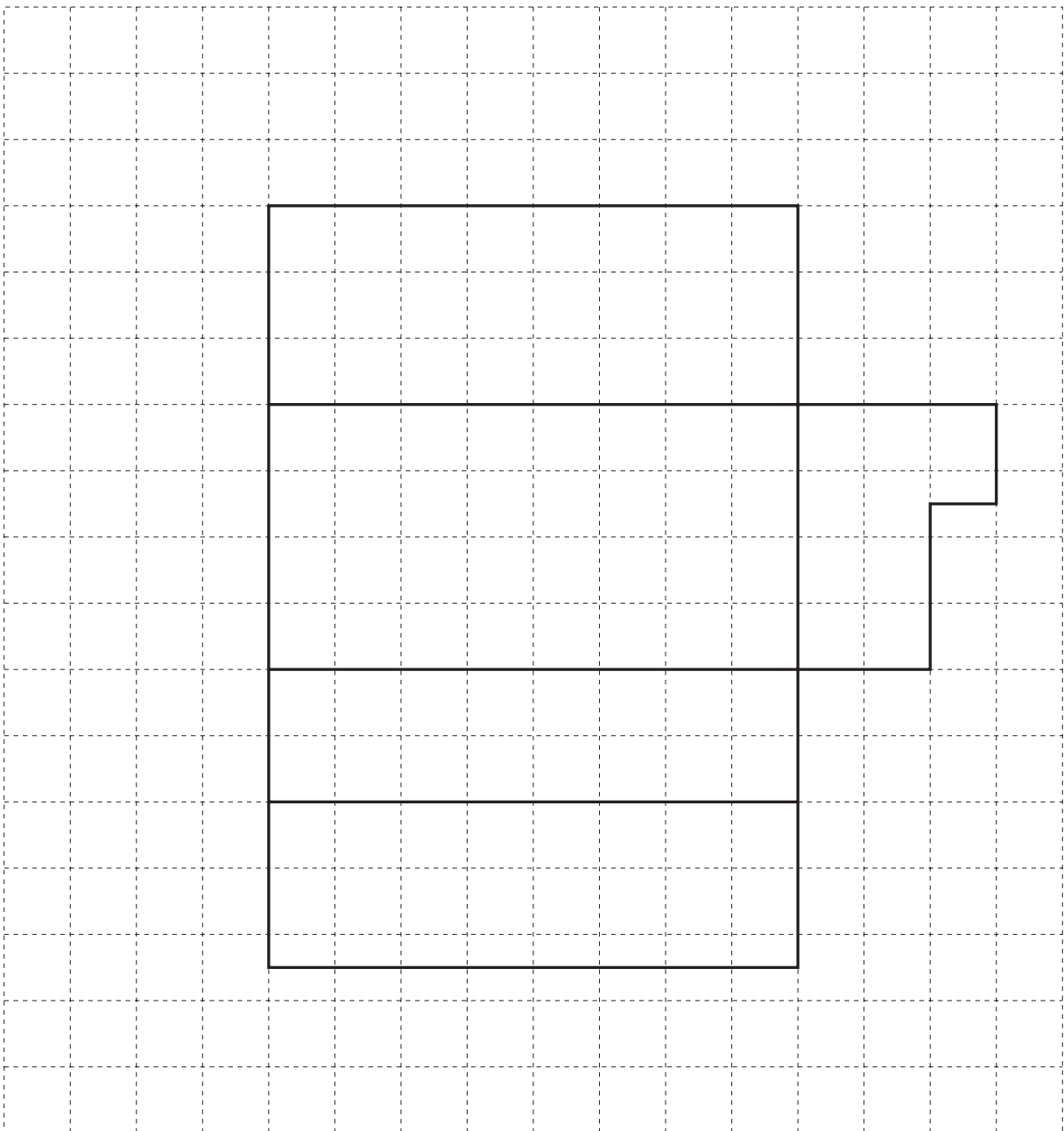

[3]

For  
Examiner's  
Use



16 Daniel invested \$2500 for 2 years at 5.5% per year **compound** interest.

Calculate how much interest he received.

Answer \$ ..... [3]

17

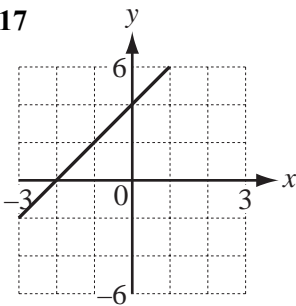

A

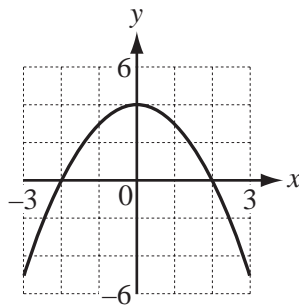

B

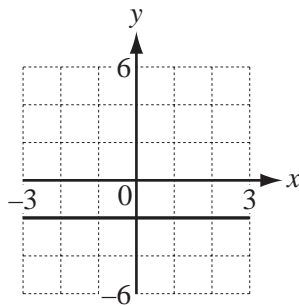

C

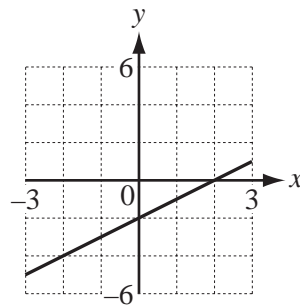

D

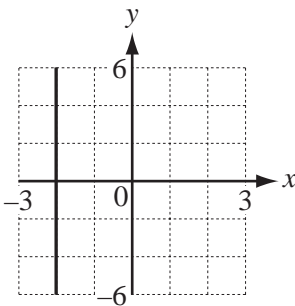

E

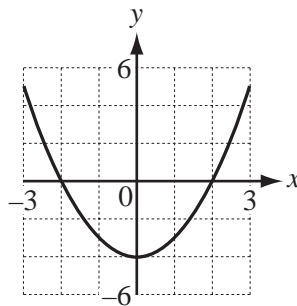

F

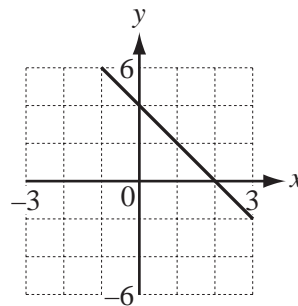

G

Write down the letter of the graph which is

(a)  $y = x - 2$ ,

Answer(a) ..... [1]

(b)  $x = -2$ ,

Answer(b) ..... [1]

(c)  $y = -2x + 4$ ,

Answer(c) ..... [1]

(d)  $y = x^2 - 4$ .

Answer(d) ..... [1]

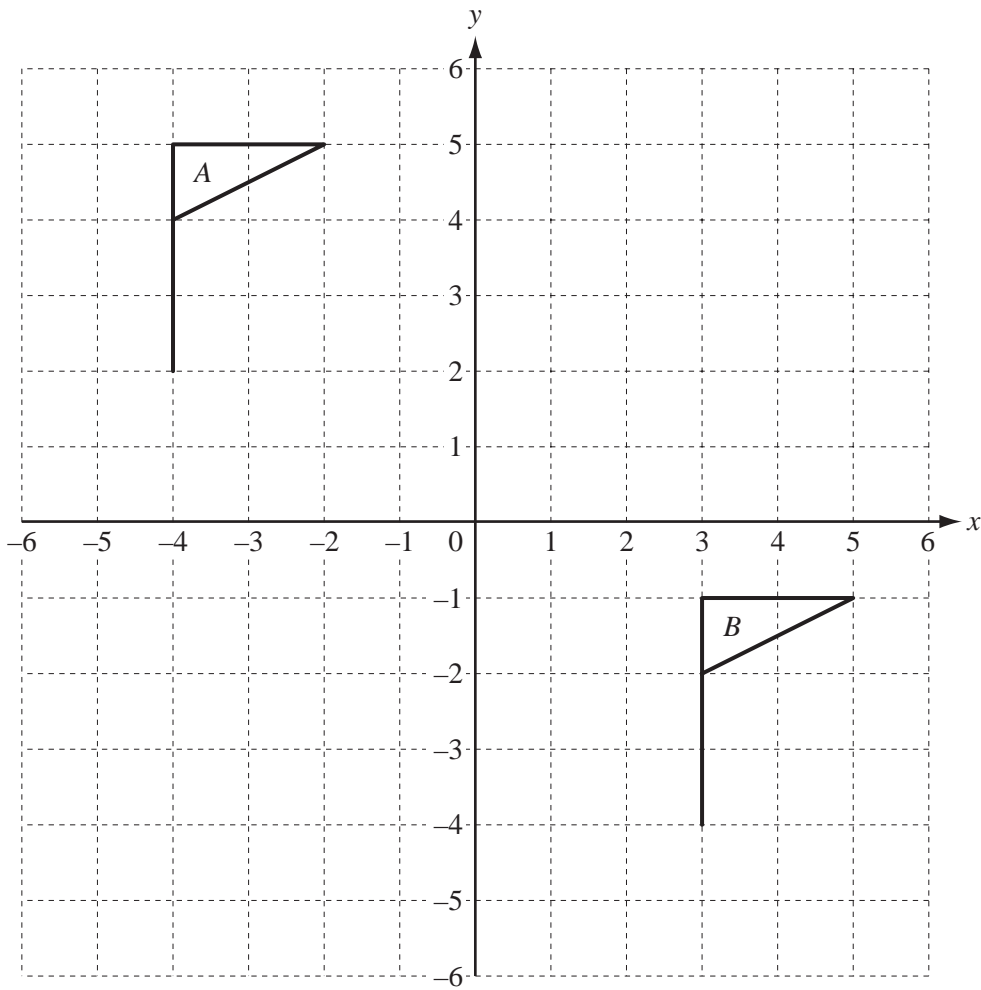

(a) Describe fully the **single** transformation which maps flag *A* onto flag *B*.

Answer(a) ..... [2]

(b) Draw, on the grid above, the image of flag *A* after rotation through  $90^\circ$  clockwise about the origin. [2]

19 The diagram shows a door,  $AEBCD$ , from a model of a house.

$ABCD$  is a rectangle and  $AEB$  is a semi-circle.

$AD = 14$  cm and  $DC = 6$  cm.

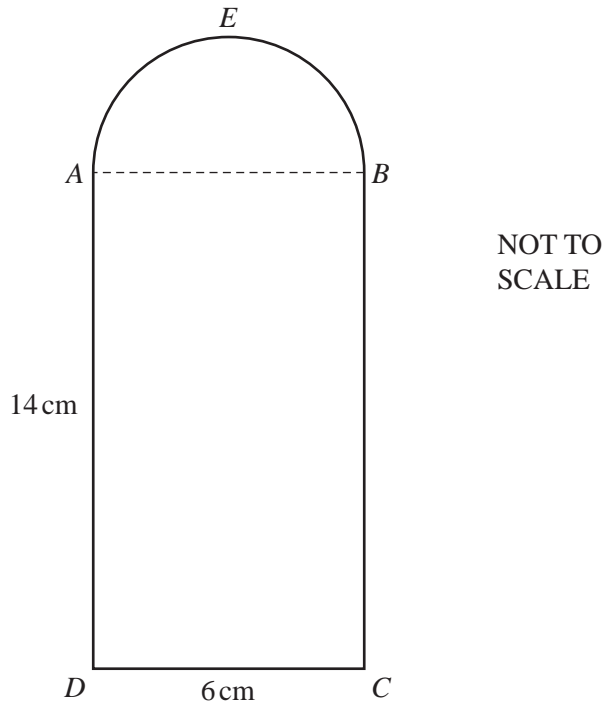

(a) Calculate the area of the door.

Answer(a) ..... cm<sup>2</sup> [3]

(b) The door is 2 millimetres thick.

Calculate, in cubic centimetres, the volume of the door.

Answer(b) ..... cm<sup>3</sup> [2]

Question 20 is printed on the next page.

- 20 A running track has a boundary that is always 40 metres from a straight line,  $AB$ .  
 $AB = 70$  m.  
 The scale drawing below shows the line  $AB$ .  
 1 centimetre represents 10 metres.

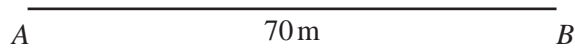

- (a) Complete the scale drawing accurately to show the boundary of the running track. [2]  
 (b) **Calculate**, in metres, the total length of the actual boundary.

*Answer(b)* ..... m [3]

Permission to reproduce items where third-party owned material protected by copyright is included has been sought and cleared where possible. Every reasonable effort has been made by the publisher (UCLES) to trace copyright holders, but if any items requiring clearance have unwittingly been included, the publisher will be pleased to make amends at the earliest possible opportunity.

University of Cambridge International Examinations is part of the Cambridge Assessment Group. Cambridge Assessment is the brand name of University of Cambridge Local Examinations Syndicate (UCLES), which is itself a department of the University of Cambridge.